

Coastal Carolina Community College Learning Resources Center First Floor Renovation

SCO#: 23-26060-01A
444 Western Boulevard
Jacksonville, North Carolina

Volume 1 of 2

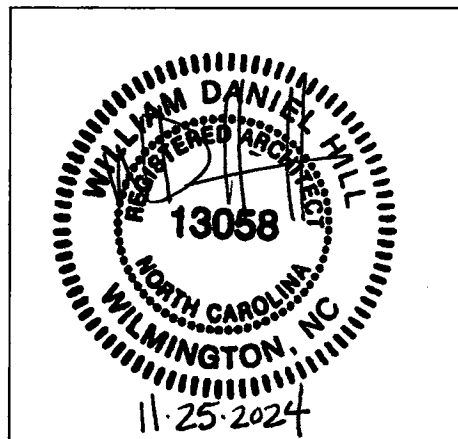
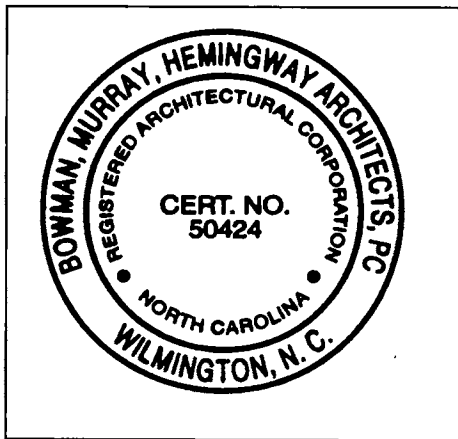

November 25, 2024

BOWMAN MURRAY HEMINGWAY ARCHITECTS

514 Market Street
Wilmington, North Carolina

TABLE OF CONTENTS
Volume 1 of 2
 Coastal Carolina Community College
 Learning Resources Center
 First Floor Renovation
 SCO#: 23-26060-01A

Division	Section Title	Pages
----------	---------------	-------

PROCUREMENT AND CONTRACTING DOCUMENTS GROUP

DIVISION 00 - PROCUREMENT REQUIREMENTS

Advertisement for Bids.....	3
Notice to Bidders	4
General Conditions of the Contract	45
Supplementary General Conditions.....	5
Guidelines for Recruitment and Selection of MBE.....	8
G702/703 Application for Payment forms	2
North Carolina Sales and Use Tax Reporting Forms	2
Consent of Surety	1
Affidavit of Release of Liens.....	1
Affidavit of Payment of Debts and Claims.....	1
 Geotechnical Report	 24

DIVISION 00 - CONTRACTING FORMS

Form of Proposal	5
Identification of HUB Certified/Minority Business Participation.....	1
Affidavit A	1
Affidavit B	1
Affidavit C	1
Affidavit D	2
Form of Bid Bond	1
Form of Construction Contract	3
Form of Performance Bond	2
Form of Payment Bond	2
Sheet for Power of Attorney	1
Sheet for Insurance Certificates	1
Approval of the Attorney General	1
Certificate By the Office of State Budget and Management	1
CCCC Class Schedule – Reference Document	8

SPECIFICATIONS GROUP

DIVISION 01 - GENERAL REQUIREMENTS

01 10 00 Summary.....	2
01 21 00 Allowances	1
01 22 00 Unit Prices	2
01 23 00 Alternates (Scope and Owner Preferred Alternates).....	3
01 25 00 Substitution Prior to Bid.....	5
01 26 00 Contract Modification Procedures.....	2
01 29 00 Payment Procedures	5

TABLE OF CONTENTS
Volume 1 of 2
Coastal Carolina Community College
Learning Resources Center
First Floor Renovation
SCO#: 23-26060-01A

Division	Section Title	Pages
01 31 00 Project Management and Coordination	3
01 32 00 Construction Progress Documentation	1
01 33 00 Submittal Procedures	5
01 41 00 Quality Assurance and Testing Requirements	3
01 42 00 References	1
01 42 33 Special Inspections	21
01 50 00 Temporary Facilities and Controls	6
01 73 00 Execution Requirements.....	4
01 73 10 Cutting and Patching	3
01 77 00 Closeout Procedures	5
 DIVISION 02 - EXISTING CONDITIONS		
02 26 10 Termite Treatment	3
02 41 19 Selective Demolition	3
02 82 10 Asbestos Abatement	1
02 83 00 Lead Paint Notification.....	12
 DIVISION 03 – CONCRETE		
03 30 00 Cast-in-Place Concrete	19
03 30 10 Vapor Retarder for Cast-In-Place Concrete	3
03 49 10 Glass-Fiber Reinforced Concrete	11
 DIVISION 04 – MASONRY		
04 22 10 Unit Masonry Assemblies	20
04 72 00 Cast Stone.....	9
 DIVISION 05 – METALS		
05 12 00 Structural Steel Framing.....	9
05 21 00 Steel Joist Framing	4
05 31 00 Steel Decking.....	5
05 73 00 Glazed Decorative Metal Railings.....	6
 DIVISION 06 - WOOD, PLASTICS, AND COMPOSITES		
06 16 00 Sheathing	4
06 40 20 Interior Architectural Woodwork	7
 DIVISION 07 - THERMAL AND MOISTURE PROTECTION		
07 21 00 Thermal Insulation.....	7
07 28 00 Membrane Air Barriers and Flexible Flashing.....	9
07 42 13 Metal Composite Material Wall Panels.....	6

TABLE OF CONTENTS
Volume 1 of 2
Coastal Carolina Community College
Learning Resources Center
First Floor Renovation
SCO#: 23-26060-01A

Division	Section Title	Pages
07 54 00 Thermoplastic Single Ply Roofing	13
07 62 00 Sheet Metal Flashing and Trim	7
07 92 00 Joint Sealants	5
 DIVISION 08 - OPENINGS		
08 11 13 Hollow Metal Doors and Frames	8
08 14 16 Flush Wood Doors.....	6
08 41 13 Aluminum Entrances and Storefronts	8
08 42 32 Sliding Automatic Entrances.....	11
08 71 00 Door Hardware	21
08 80 00 Glazing	6
 DIVISION 09 – FINISHES		
09 22 16 Non-Structural Metal Framing	8
09 25 13 Acrylic Plaster Soffit Finish.....	3
09 29 00 Gypsum Board.....	7
09 30 00 Tiling	12
09 51 13 Acoustical Panel Ceilings.....	9
09 51 26 Acoustical Wood Ceilings.....	7
09 65 13 Resilient Base and Accessories	6
09 65 19 Resilient Tile Flooring.....	5
09 65 20 Luxury Vinyl Tile Flooring.....	5
09 66 23 Resinous Matrix Terrazzo Flooring.....	8
09 68 13 Tile Carpeting.....	6
09 68 16 Sheet Carpeting	5
09 91 00 Painting.....	8
 DIVISION 10 – SPECIALTIES		
10 14 00 Signage	9
10 21 13 Toilet Compartments	4
10 28 00 Toilet, Bath, and Laundry Accessories.....	4
10 44 13 Fire Extinguisher Cabinets and Accessories	3
 DIVISION 12 – FURNISHINGS		
12 24 13 Roller Shades.....	4
 DIVISION 14 – CONVEYING EQUIPMENT		
14 24 00.0 Hydraulic Elevator Modernization	6

END TABLE OF CONTENTS VOLUME 1 OF 2

ADVERTISEMENT FOR BIDS

**Learning Resources Center
First Floor Renovation
444 Western Boulevard
Jacksonville, NC 28546
SCO#: 23-26060-01A**

Sealed proposals will be received by Coastal Carolina Community College in the 2nd Floor Conference Room (Room 207) of the Institutional Support Services Building at 444 Western Boulevard, Jacksonville, NC 28546, on Tuesday, January 14, 2025, at 10:00 am and immediately thereafter publicly opened and read for construction of Learning Resources Center First Floor Renovation.

A **mandatory** pre-bid conference will be held Tuesday, December 17, 2024, at 10:00 am. in the 2nd Floor Conference Room (Room 207) of the Institutional Support Services Building at 444 Western Boulevard, Jacksonville, NC 28546.

Project Scope and Owner Preferred Brand Alternates will also be addressed at this prebid conference. In accordance with GS 133-3 the following items are being considered by the owner for this project:

Project Scope Alternates:

Alternate #1: State amount to be added to the base bid to provide all labor and material to provide Covered Canopy 140. Alternate to include all architectural, structural, plumbing, mechanical and electrical work involved in construction of Covered Canopy 140 as shown on A2.0 and A3.0. Base bid to include doors 134B and sidewalks as shown on A2.1. Base bid to include infiltration trenches as delineated on civil drawings.

Alternate #2: State the amount to be added to the base bid to provide labor and material for the complete installation of a standby power system including new natural gas fueled engine-generator set, automatic transfer switch and associated conductors, conduit and equipment as shown on electrical and plumbing drawings in the construction documents.

Alternate #3: State the amount to be added to the base bid to provide labor and material for precast terrazzo treads and risers and precast terrazzo tiles as delineated at the central stair on drawing sheet A5.0 and in specific section 096623 Resinous Matrix Terrazzo Flooring. Work to include removal of metal nosing at existing stair treads. Base bid shall include sheet carpeting at central stair as specified.

Owner Preferred Brand Alternates:

Alternate #4: State the amount to be added to the base bid to provide the basis of design door hardware as specified in section 087100:

Hinges and Butts:	McKinney: TB2714/TB2314/T4B3786/T4B3386
Continuous Hinges:	Ives: 224HD
Cylinders and Keying:	Corbin Russwin
Mortise Locks:	Corbin Russwin ML2000 x LWA

Cylindrical Locks:	Corbin Russwin CL3300 Series
Door Closers:	LCN 4040XP/4040XP
Exit Devices:	Von Duprin 99 Series

Alternate #5: State the amount to be added to the base bid to provide Sliding Automatic Entrances by Stanley Automatic Sliding Doors as specified in Section 084232.

Alternate #6: State the amount to be added to the base bid to provide fire alarm systems and devices by Notifier as specified in section 283111.

Alternate #7: State the amount to be added to the base bid to provide Schneider Electric DDC system as specified in section 230923 DIRECT DIGITAL CONTROL SYSTEM FOR HVAC, drawing M7.1, and drawing M7.2.

Alternate #8: State the amount to be added to the base bid to provide telecommunication structured cabling systems and devices by Amp Netconnect as specified in section 271500.

Alternate #9: State the amount to be added to the base bid to provide the basis of design plumbing fixtures as scheduled on drawing P0.2:

1. WC-1 ADA Water Closet: American Standard 3043.001.020, Sloan 111-1.28-DFB, Bemis Manufacturing Co. 1955SSCT.
2. WC-2 Water Closet: American Standard 2234.001.020, Sloan 113-1.28-DFB-Z, Bemis Manufacturing Co. 1955SSCT.
3. UR-1 Urinal: American Standard 6590001.020, Sloan 186-0.125-DBP, Zurn Z1221-UNIV.
4. LAV-1 ADA Lavatory: American Standard 0497.221.020, Moen 8894, Jones Stephens D70100.
5. SK-1 2-Compartment Sink: Elkay LR33223, Moen 8701, Elkay LK35.
6. FD-1 Floor Drain: Sioux Chief 832-4PNR.
7. HB-1 Hose Bibb: Woodford 24P.
8. OB-1 Ice Maker Box: Sioux Chief 696-G1010XF.

Alternate #10: State the amount to be added to the base bid to provide Trane EXHG Ground-coupled heat pumps as scheduled on drawing M6.1.

Alternate #11: State the amount to be added to the base bid to provide elevator modernization to the main elevator in the Learning Resources Center Building (TKE Serial # US155244) by **TKE** as specified in section 142400.5 Hydraulic Elevator Modernization.

Justification of any approvals will be made available to the public in writing no later than seven (7) days prior to bid date.

Complete plans and specifications for this project can be obtained exclusively by contacting Bowman Murray Hemingway Architects, 514 Market Street, Wilmington, NC 28401, (910) 762-2621 or bowers@bhmharch.com during normal office hours.

Plan Deposit is \$100.00.

Electronic copies of plans and specifications will be distributed in PDF format at no cost.

The owner reserves the unqualified right to reject any and all proposals.

Coastal Carolina Community College
444 Western Boulevard
Jacksonville, NC 28546

NOTICE TO BIDDERS

Learning Resources Center First Floor Renovation
444 Western Blvd.
Jacksonville, NC 28546
SCO#: 23-26060-01A

Sealed proposals will be received by Coastal Carolina Community College in the 2nd Floor Conference Room (Room 207) of the Institutional Support Services Building at 444 Western Boulevard, Jacksonville, NC 28546, on Tuesday, January 14, 2025, at 10:00 am. and immediately thereafter publicly opened and read for construction of Learning Resources Center First Floor Renovation.

The project scope includes renovation to the first floor of the existing Learning Resources Center located on the main campus of Coastal Carolina Community College. Work involves but is not limited to selective demolition, new finishes, windows and doors, gypsum and light gauge metal framing, and new plumbing, mechanical and electrical systems. The College intends for the second floor to remain occupied and in use by the College during the course of construction.

Bids will be received for a single prime contract - General Construction (which includes plumbing, mechanical and electrical). All proposals shall be lump sum.

Project name, contractor's name, and contractor's license number must be clearly marked on the outside of the bid envelope.

You may submit your bid package in advance of the opening date. Your sealed envelope will be held and unsealed at the bid opening time. **If you wish to send your bid via US Mail, FedEx or UPS**, please allow several days for delivery since the **bid must be received (NOT postmarked)** by the date and time stated in the solicitation.

Pre-Bid Meeting

A **mandatory pre-bid conference** will be held Tuesday, December 17, 2024, at 10:00 am in the 2nd Floor Conference Room of the ISS Building at 444 Western Boulevard, Jacksonville, NC 28546.

The meeting is also to identify **preferred brand alternates** and their performance standards that the owner will consider for approval on this project. In accordance with General Statute GS 133-3, Specifications may list one or more preferred brands as an alternate to the base bid in limited circumstances. Specifications containing a preferred brand alternate under this section must identify the performance standards that support the preference. Performance standards for the preference must be approved in advance by the owner in an open meeting. Any alternate approved by the owner shall be approved only where (i) the preferred alternate will provide cost savings, maintain or improve the functioning of any process or system affected by the preferred item or items, or both, and (ii) a justification identifying these criteria is made available in writing to the public.

In accordance with GS133-3 and SCO procedures the following project scope and owner preferred brand items are being considered as Alternates by the owner for this project:

Project Scope Alternates:

- Alternate #1: State amount to be added to the base bid to provide all labor and material to provide Covered Canopy 140. Alternate to include all architectural, structural, plumbing, mechanical and electrical work involved in construction of Covered Canopy 140 as shown on A2.0 and A3.0. Base bid to include doors 134B and sidewalks as shown on A2.1. Base bid to include infiltration trenches as delineated on civil drawings.
- Alternate #2: State the amount to be added to the base bid to provide labor and material for the complete installation of a standby power system including new natural gas fueled engine-generator set, automatic transfer switch and associated conductors, conduit and equipment as shown on electrical and plumbing drawings in the construction documents.
- Alternate #3: State the amount to be added to the base bid to provide labor and material for precast terrazzo treads and risers and precast terrazzo tiles as delineated at the central stair on drawing sheet A5.0 and in specific section 096623 Resinous Matrix Terrazzo Flooring. Work to include removal of metal nosing at existing stair treads. Base bid shall include sheet carpeting at central stair as specified.

Owner Preferred Brand Alternates:

- Alternate #4: State the amount to be added to the base bid to provide the basis of design door hardware as specified in section 087100:

Hinges and Butts:	McKinney: TB2714/TB2314/T4B3786/T4B3386
Continuous Hinges:	Ives: 224HD
Cylinders and Keying:	Corbin Russwin
Mortise Locks:	Corbin Russwin ML2000 x LWA
Cylindrical Locks:	Corbin Russwin CL3300 Series
Door Closers:	LCN 4040XP/4040XP
Exit Devices:	Von Duprin 99 Series

- Alternate #5: State the amount to be added to the base bid to provide Sliding Automatic Entrances by Stanley Automatic Sliding Doors as specified in Section 084232.
- Alternate #6: State the amount to be added to the base bid to provide fire alarm systems and devices by Notifier as specified in section 283111.
- Alternate #7: State the amount to be added to the base bid to provide Schneider Electric DDC system as specified in section 230923 DIRECT DIGITAL CONTROL SYSTEM FOR HVAC, drawing M7.1, and drawing M7.2.
- Alternate #8: State the amount to be added to the base bid to provide telecommunication structured cabling systems and devices by Amp Netconnect as specified in section 271500.
- Alternate #9: State the amount to be added to the base bid to provide the basis of design plumbing fixtures as scheduled on drawing P0.2:

1. WC-1 ADA Water Closet: American Standard 3043.001.020, Sloan 111-1.28-DFB, Bemis Manufacturing Co. 1955SSCT.

2. WC-2 Water Closet: American Standard 2234.001.020, Sloan 113-1.28-DFB-Z, Bemis Manufacturing Co. 1955SSCT.
3. UR-1 Urinal: American Standard 6590001.020, Sloan 186-0.125-DBP, Zurn Z1221-UNIV.
4. LAV-1 ADA Lavatory: American Standard 0497.221.020, Moen 8894, Jones Stephens D70100.
5. SK-1 2-Compartment Sink: Elkay LR33223, Moen 8701, Elkay LK35.
6. FD-1 Floor Drain: Sioux Chief 832-4PNR.
7. HB-1 Hose Bibb: Woodford 24P.
8. OB-1 Ice Maker Box: Sioux Chief 696-G1010XF.

Alternate #10: State the amount to be added to the base bid to provide Trane EXHG Ground-coupled heat pumps as scheduled on drawing M6.1.

Alternate #11: State the amount to be added to the base bid to provide elevator modernization to the main elevator in the Learning Resources Center Building (TKE Serial # US155244) by **TKE** as specified in section 142400.5 Hydraulic Elevator Modernization.

Justification of any approvals will be made available to the public in writing no later than seven (7) days prior to bid date.

Complete plans and specifications may be obtained from design consultant Bowman Murray Hemingway Architects, 514 Market St., Wilmington, NC 28401, (910-762-2621) during normal office hours beginning December 9, 2024. A refundable plan deposit in the amount of \$100 is required. Partial sets will not be available. Plan deposits shall be mailed to Bowman Murray Hemingway Architects, 514 Market St., Wilmington, NC 28401, attention Susie Bowers. The deposit will be refunded upon return of the Contract Documents in good condition within thirty (30) days.

PDF versions of the construction documents may be obtained by emailing bowers@bmharch.com and are available at no cost.

NOTE: The bidder shall include with the bid proposal the form *Identification of Minority Business Participation* identifying the minority business participation it will use on the project and shall include either *Affidavit A* or *Affidavit B* as applicable. Forms and instructions are included within the Proposal Form in the bid documents. Failure to complete these forms is grounds for rejection of the bid. (GS143-128.2c Effective 1/1/2002.)

All contractors are hereby notified that they must have proper license as required under the state laws governing their respective trades.

General contractors are notified that Chapter 87, Article 1, General Statutes of North Carolina, will be observed in receiving and awarding general contracts. General contractors submitting bids on this project must have license classification for Building - Unlimited as required by the General Contractors Licensing Board under G.S.87-1.

Each proposal shall be accompanied by a cash deposit, or a certified check drawn on some bank or trust company, insured by the Federal Deposit Insurance Corporation, of an amount equal to not less than five percent (5%) of the proposal, or in lieu thereof a bidder may offer a bid bond of five percent (5%) of the bid executed by a surety company licensed under the laws of North Carolina to execute the contract in accordance with the bid bond. Said deposit shall be retained by the owner as liquidated damages in event of

failure of the successful bidder to execute the contract within ten days after the award or to give satisfactory surety as required by law.

A performance bond and a payment bond will be required for one hundred percent (100%) of the contract price.

Payment will be made based on ninety-five percent (95%) of monthly estimates and final payment made upon completion and acceptance of work.

No bid may be withdrawn after the scheduled closing time for the receipt of bids for a period of 60 days.

The owner reserves the right to reject any or all bids and to waive informalities.

Designer:
Daniel Hill, AIA
Bowman Murray Hemingway Architects
514 Market Street
Wilmington, NC 28401
910-762-2621

Owner:
Coastal Carolina Community College
444 Western Boulevard
Jacksonville, NC 28546

**INSTRUCTIONS TO BIDDERS
AND
GENERAL CONDITIONS OF THE CONTRACT**

STANDARD FORM FOR CONSTRUCTION PROJECTS

**STATE CONSTRUCTION OFFICE
NORTH CAROLINA
DEPARTMENT OF ADMINISTRATION**

Form OC-15

This document is intended for use on State capital construction projects and shall not be used on any project that is not reviewed and approved by the State Construction Office. Extensive modification to the General Conditions by means of “Supplementary General Conditions” is strongly discouraged. State agencies and institutions may include special requirements in “Division 1 – General Requirements” of the specifications, where they do not conflict with the General Conditions.

**Twenty Fourth Edition January 2013
Revision 1 - May 2024: Article 23.b**

INSTRUCTIONS TO BIDDERS

For a proposal to be considered it must be in accordance with the following instructions:

1. PROPOSALS

Proposals must be made in strict accordance with the Form of Proposal provided therefor, and all blank spaces for bids, alternates, and unit prices applicable to bidder's work shall be properly filled in. When requested alternates are not bid, the proposer shall so indicate by the words "No Bid". Any blanks shall also be interpreted as "No Bid". The bidder agrees that bid on Form of Proposal detached from specifications will be considered and will have the same force and effect as if attached thereto. Photocopied or faxed proposals will not be considered. Numbers shall be stated both in writing and in figures for the base bids and alternates. If figures and writing differ, the written number will supersede the figures.

Any modifications to the Form of Proposal (including alternates and/or unit prices) will disqualify the bid and may cause the bid to be rejected.

The bidder shall fill in the Form of Proposal as follows:

- a. If the documents are executed by a sole owner, that fact shall be evidenced by the word "Owner" appearing after the name of the person executing them.
- b. If the documents are executed by a partnership, that fact shall be evidenced by the word "Co-Partner" appearing after the name of the partner executing them.
- c. If the documents are executed on the part of a corporation, they shall be executed by either the president or the vice president and attested by the secretary or assistant secretary in either case, and the title of the office of such persons shall appear after their signatures. The seal of the corporation shall be impressed on each signature page of the documents.
- d. If the proposal is made by a joint venture, it shall be executed by each member of the joint venture in the above form for sole owner, partnership or corporation, whichever form is applicable.
- e. All signatures shall be properly witnessed.
- f. If the contractor's license of a bidder is held by a person other than an owner, partner or officer of a firm, then the licensee shall also sign and be a party to the proposal. The title "Licensee" shall appear under his/her signature.

Proposals should be addressed as indicated in the Advertisement for Bids and be delivered, enclosed in an opaque sealed envelope, marked "Proposal" and bearing the title of the work, name of the bidder, and the contractor's license number of the bidder. Bidders should clearly mark on the outside of the bid envelope which contract(s) they are bidding.

Bidder shall identify on the bid, the minority businesses that will be utilized on the project with corresponding total dollar value of the bid and affidavit listing good faith efforts or an affidavit indicating work under contract will be self-performed, as required by G.S. 143-128.2(c) and G.S. 143-128.2(f). Failure to comply with these requirements is grounds for rejection of the bid.

For projects bid in the single-prime alternative, the names and license numbers of major subcontractors shall be listed on the proposal form.

It shall be the specific responsibility of the bidder to deliver his bid to the proper official at the selected place and prior to the announced time for the opening of bids. Later delivery of a bid for any reason, including delivery by any delivery service, shall disqualify the bid.

Unit prices quoted in the proposal shall include overhead and profit and shall be the full compensation for the contractor's cost involved in the work. See General Conditions, Article 19c-1.

2. EXAMINATION OF CONDITIONS

It is understood and mutually agreed that by submitting a bid the bidder acknowledges that he has carefully examined all documents pertaining to the work, the location, accessibility and general character of the site of the work and all existing buildings and structures within and adjacent to the site, and has satisfied himself as to the nature of the work, the condition of existing buildings and structures, the conformation of the ground, the character, quality and quantity of the material to be encountered, the character of the equipment, machinery, plant and any other facilities needed preliminary to and during prosecution of the work, the general and local conditions, the construction hazards, and all other matters, including, but not limited to, the labor situation which can in any way affect the work under the contract, and including all safety measures required by the Occupational Safety and Health Act of 1970 and all rules and regulations issued pursuant thereto. It is further mutually agreed that by submitting a proposal the bidder acknowledges that he has satisfied himself as to the feasibility and meaning of the plans, drawings, specifications and other contract documents for the construction of the work and that he accepts all the terms, conditions and stipulations contained therein; and that he is prepared to work in cooperation with other contractors performing work on the site.

Reference is made to contract documents for the identification of those surveys and investigation reports of subsurface or latent physical conditions at the site or otherwise affecting performance of the work which have been relied upon by the designer in preparing the documents. The owner will make copies of all such surveys and reports available to the bidder upon request.

Each bidder may, at his own expense, make such additional surveys and investigations as he may deem necessary to determine his bid price for the performance of the work. Any on-site investigation shall be done at the convenience of the owner. Any reasonable request for access to the site will be honored by the owner.

3. BULLETINS AND ADDENDA

Any addenda to specifications issued during the time of bidding are to be considered covered in the proposal and in closing a contract they will become a part thereof. It shall be the bidder's responsibility to ascertain prior to bid time the addenda issued and to see that his bid includes any changes thereby required.

Should the bidder find discrepancies in, or omission from, the drawings or documents or should he be in doubt as to their meaning, he shall at once notify the designer who will send written instructions in the form of addenda to all bidders. Notification should be no later than seven (7) days prior to the date set for receipt of bids. Neither the owner nor the designer will be responsible for any oral instructions.

All addenda should be acknowledged by the bidder(s) on the Form of Proposal. However, even if not acknowledged, by submitting a bid, the bidder has certified that he has reviewed all issued addenda and has included all costs associated within his bid.

4. BID SECURITY

Each proposal shall be accompanied by a cash deposit or a certified check drawn on some bank or trust company insured by the Federal Deposit Insurance Corporation, or a bid bond in an amount equal to not less than five percent (5%) of the proposal, said deposit to be retained by the owner as liquidated damages in event of failure of the successful bidder to execute the contract within ten (10) days after the award or to give satisfactory surety as required by law (G.S. 143-129).

Bid bond shall be conditioned that the surety will, upon demand, forthwith make payment to the obligee upon said bond if the bidder fails to execute the contract. The owner may retain bid securities of any bidder(s) who may have a reasonable chance of award of contract for the full duration of time stated in the Notice to Bidders. Other bid securities may be released sooner, at the discretion of the owner. All bid securities (cash or certified checks) shall be returned to the bidders promptly after award of contracts, and no later than seven (7) days after expiration of the holding period stated in the Notice to Bidders. Standard Form of Bid Bond is included in these specifications and shall be used.

5. RECEIPT OF BIDS

Bids shall be received in strict accordance with requirements of the General Statutes of North Carolina. Bid security shall be required as prescribed by statute. Prior to the closing of the bid, the bidder will be permitted to change or withdraw his bid. Guidelines for opening of public construction bids are available from the State Construction Office.

6. OPENING OF BIDS

Upon opening, all bids shall be read aloud. Once bidding is closed, there shall not be any withdrawal of bids by any bidder and no bids may be returned by the designer to any bidder. After the opening of bids, no bid may be withdrawn, except under the provisions of General Statute 143-129.1, for a period of thirty days unless otherwise specified. Should the successful bidder default and fail to execute a contract, the contract may be awarded to the next lowest and responsible bidder. The owner reserves the unqualified right to reject any and all bids. Reasons for rejection may include, but shall not be limited to, the following:

- a. If the Form of Proposal furnished to the bidder is not used or is altered.
- b. If the bidder fails to insert a price for all bid items, alternate and unit prices requested.
- c. If the bidder adds any provisions reserving the right to accept or reject any award.
- d. If there are unauthorized additions or conditional bids, or irregularities of any kind which tend to make the proposal incomplete, indefinite or ambiguous as to its meaning.
- e. If the bidder fails to complete the proposal form where information is requested so the bid may be properly evaluated by the owner.
- f. If the unit prices contained in the bid schedule are unacceptable to the owner and the State Construction Office.
- g. If the bidder fails to comply with other instructions stated herein.

7. BID EVALUATION

The award of the contract will be made to the lowest responsible bidder as soon as practical. The owner may award on the basis of the base bid and any alternates the owner chooses.

Before awarding a contract, the owner may require the apparent low bidder to qualify himself to be a responsible bidder by furnishing any or all of the following data:

- a. The latest financial statement showing assets and liabilities of the company or other information satisfactory to the owner.
- b. A listing of completed projects of similar size.
- c. Permanent name and address of place of business.
- d. The number of regular employees of the organization and length of time the organization has been in business under present name.
- e. The name and home office address of the surety proposed and the name and address of the responsible local claim agent.
- f. The names of members of the firms who hold appropriate trade licenses, together with license numbers.
- g. If prequalified, contractor info will be reviewed and evaluated comparatively to submitted prequalification package.

Failure or refusal to furnish any of the above information, if requested, shall constitute a basis for disqualification of any bidder.

In determining the lowest responsible, responsive bidder, the owner shall take into consideration the bidder's compliance with the requirements of G.S. 143-128.2(c), the past performance of the bidder on construction contracts for the State with particular concern given to completion times, quality of work, cooperation with other contractors, and cooperation with the designer and owner. Failure of the low bidder to furnish affidavit and/or documentation as required by G.S. 143-128.2(c) shall constitute a basis for disqualification of the bid.

Should the owner adjudge that the apparent low bidder is not the lowest responsible, responsive bidder by virtue of the above information, said apparent low bidder will be so notified and his bid security shall be returned to him.

8. PERFORMANCE BOND

The successful bidder, upon award of contract, shall furnish a performance bond in an amount equal to 100 percent of the contract price. See Article 35, General Conditions.

9. PAYMENT BOND

The successful bidder, upon award of contract, shall furnish a payment bond in an amount equal to 100 percent of the contract price. See Article 35, General Conditions.

10. PAYMENTS

Payments to the successful bidders (contractors) will be made on the basis of monthly estimates. See Article 31, General Conditions.

11. PRE-BID CONFERENCE

Prior to the date set for receiving bids, the Designer may arrange and conduct a Pre-Bid Conference for all prospective bidders. The purpose of this conference is to review project requirements and to respond to questions from prospective bidders and their subcontractors or material suppliers related to the intent of bid documents. Attendance by prospective bidders shall be as required by the "Notice to Bidders".

12. SUBSTITUTIONS

In accordance with the provisions of G.S. 133-3, material, product, or equipment substitutions proposed by the bidders to those specified herein can only be considered during the bidding phase until ten (10) days prior to the receipt of bids when submitted to the Designer with sufficient data to confirm material, product, or equipment equality. Proposed substitutions submitted after this time will be considered only as potential change order.

Submittals for proposed substitutions shall include the following information:

- a. Name, address, and telephone number of manufacturer and supplier as appropriate.
- b. Trade name, model or catalog designation.
- c. Product data including performance and test data, reference standards, and technical descriptions of material, product, or equipment. Include color samples and samples of available finishes as appropriate.
- d. Detailed comparison with specified products including performance capabilities, warranties, and test results.
- e. Other pertinent data including data requested by the Designer to confirm product equality.

If a proposed material, product, or equipment substitution is deemed equal by the Designer to those specified, all bidders of record will be notified by Addendum.

GENERAL CONDITIONS OF THE CONTRACT

The use or reproduction of this document or any part thereof is authorized for and limited to use on projects of the State of North Carolina, and is distributed by, through and at the discretion of the State Construction Office, Raleigh, North Carolina, for that distinct and sole purpose.

TABLE OF CONTENTS

ARTICLE	TITLE	PAGE
1	Definitions.....	9
2	Intent and Execution of Documents	11
3	Clarifications and Detail Drawings	12
4	Copies of Drawings and Specifications.....	12
5	Shop Drawings, Submittals, Samples, Data	13
6	Working Drawings and Specifications at the Job Site	13
7	Ownership of Drawings and Specifications	14
8	Materials, Equipment, Employees	14
9	Royalties, Licenses and Patent	15
10	Permits, Inspections, Fees, Regulations	15
11	Protection of Work, Property and the Public	16
12	Sedimentation Pollution Control Act of 1973	17
13	Inspection of the Work.....	17
14	Construction Supervision and Schedule	18
15	Separate Contracts and Contractor Relationships.....	22
16	Subcontracts and Subcontractors	23
17	Contractor and Subcontractor Relationships.....	23
18	Designer's Status	24
19	Changes in the Work	25
20	Claims for Extra Cost	27
21	Minor Changes in the Work	29
22	Uncorrected Faulty Work.....	29
23	Time of Completion, Delays, Extension of Time	29
24	Partial Utilization: Beneficial Occupancy	30
25	Final Inspection, Acceptance, and Project Closeout	31
26	Correction of Work Before Final Payment	31
27	Correction of Work After Final Payment	32
28	Owner's Right to Do Work	32
29	Annulment of Contract.....	32
30	Contractor's Right to Stop Work or Terminate the Contract	33
31	Requests for Payments	33
32	Certificates of Payment and Final Payment.....	34
33	Payments Withheld.....	36
34	Minimum Insurance Requirements.....	36
35	Performance Bond and Payment Bond.....	37
36	Contractor's Affidavit.....	38
37	Assignments	38
38	Use of Premises.....	38
39	Cutting, Patching and Digging.....	38
40	Utilities, Structures, Signs	38
41	Cleaning Up.....	40
42	Guarantee	41

43 Codes and Standards41
44 Indemnification.....41
45 Taxes41
46 Equal Opportunity Clause.....42
47 Employment of the Handicapped42
48 Asbestos-Containing Materials (ACM)43
49 Minority Business Participation.....43
50 Contractor Evaluation43
51 Gifts43
52 Auditing Access to Persons and Records.....44
53 North Carolina False Claims Act44
54 Termination for Convenience45

ARTICLE 1 - DEFINITIONS

- a. The **contract documents** consist of the Notice to Bidders; Instructions to Bidders; General Conditions of the Contract; special conditions if applicable; Supplementary General Conditions; the drawing and specifications, including all bulletins, addenda or other modifications of the drawings and specifications incorporated into the documents prior to their execution; the proposal; the contract; the performance bond; the payment bond; insurance certificates; the approval of the attorney general; and the certificate of the Office of State Budget and Management. All of these items together form the contract.
- b. The **owner** is the State of North Carolina through the agency named in the contract.
- c. The **designer(s)** are those referred to within this contract, or their authorized representatives. The Designer(s), as referred to herein, shall mean architect and/or engineer. They will be referred to hereinafter as if each were of the singular number, masculine gender.
- d. The **contractor**, as referred to hereinafter, shall be deemed to be either of the several contracting parties called the "Party of the First Part" in either of the several contracts in connection with the total project. Where, in special instances hereinafter, a particular contractor is intended, an adjective precedes the word "contractor," as "general," "heating," etc. For the purposes of a single prime contract, the term Contractor shall be deemed to be the single contracting entity identified as the "Party of the First Part" in the single Construction Contract. Any references or adjectives that name or infer multiple prime contractors shall be interpreted to mean the single prime Contractor.
- e. A **subcontractor**, as the term is used herein, shall be understood to be one who has entered into a direct contract with a contractor, and includes one who furnishes materials worked to a special design in accordance with plans and specifications covered by the contract, but does not include one who only sells or furnishes materials not requiring work so described or detailed.
- f. **Written notice** shall be defined as notice in writing delivered in person to the contractor, or to a partner of the firm in the case of a partnership, or to a member of the contracting organization, or to an officer of the organization in the case of a corporation, or sent to the last known business address of the contracting organization by registered mail.
- g. **Work**, as used herein as a noun, is intended to include materials, labor, and workmanship of the appropriate contractor.
- h. The **project** is the total construction work to be performed under the contract documents by the several contractors.
- i. **Project Expediter**, as used herein, is an entity stated in the contract documents, designated to effectively facilitate scheduling and coordination of work activities. See Article 14(f) for responsibilities of a Project Expediter. **For the purposes of a single prime contract, the single prime contractor shall be designated as the Project Expediter.**
- j. **Change order**, as used herein, shall mean a written order to the contractor subsequent to the signing of the contract authorizing a change in the contract. The change order shall be signed by the contractor, designer and the owner, and approved by the State Construction Office, in that order (Article 19).

- k. **Field Order**, as used herein, shall mean a written approval for the contractor to proceed with the work requested by owner prior to issuance of a formal Change Order. The field order shall be signed by the contractor, designer, owner, and State Construction Office.
- l. **Time of completion**, as stated in the contract documents, is to be interpreted as consecutive calendar days measured from the date established in the written Notice to Proceed, or such other date as may be established herein (Article 23).
- m. **Liquidated damages**, as stated in the contract documents [, is an amount reasonably estimated in advance to cover the consequential damages associated with the Owner's economic loss in not being able to use the Project for its intended purposes at the end of the contract's completion date as amended by change order, if any, by reason of failure of the contractor(s) to complete the work within the time specified. Liquidated damages does not include the Owner's extended contract administration costs (including but not limited to additional fees for architectural and engineering services, testing services, inspection services, commissioning services, etc.), such other damages directly resulting from delays caused solely by the contractor, or consequential damages that the Owner identified in the bid documents that may be impacted by any delay caused solely by the Contractor (e.g., if a multi-phased project-subsequent phases, delays in start other projects that are dependent on the completion of this Project, extension of leases and/or maintenance agreements for other facilities).
- n. **Surety**, as used herein, shall mean the bonding company or corporate body which is bound with and for the contractor, and which engages to be responsible for the contractor and his acceptable performance of the work.
- o. **Routine written communications between the Designer and the Contractor** are any communication other than a "request for information" provided in letter, memo, or transmittal format, sent by mail, courier, electronic mail, or facsimile. Such communications can not be identified as "request for information".
- p. **Clarification or Request for information (RFI)** is a request from the Contractor seeking an interpretation or clarification by the Designer relative to the contract documents. The RFI, which shall be labeled (RFI), shall clearly and concisely set forth the issue or item requiring clarification or interpretation and why the response is needed. The RFI must set forth the Contractor's interpretation or understanding of the contract documents requirements in question, along with reasons for such an understanding.
- q. **Approval** means written or imprinted acknowledgement that materials, equipment or methods of construction are acceptable for use in the work.
- r. **Inspection** shall mean examination or observation of work completed or in progress to determine its compliance with contract documents.
- s. **"Equal to" or "approved equal"** shall mean materials, products, equipment, assemblies, or installation methods considered equal by the bidder in all characteristics (physical, functional, and aesthetic) to those specified in the contract documents. Acceptance of equal is subject to approval of Designer and owner.
- t. **"Substitution" or "substitute"** shall mean materials, products, equipment, assemblies, or installation methods deviating in at least one characteristic (physical, functional, or aesthetic) from those specified, but which in the opinion of the bidder would improve competition and/or enhance the finished installation. Acceptance of substitution is subject to the approval of the Designer and owner.

- u. **Provide** shall mean furnish and install complete in place, new, clean, operational, and ready for use.
- v. **Indicated and shown** shall mean provide as detailed, or called for, and reasonably implied in the contract documents.
- w. **Special inspector** is one who inspects materials, installation, fabrication, erection or placement of components and connections requiring special expertise to ensure compliance with the approved construction documents and referenced standards.
- x. **Commissioning** is a quality assurance process that verifies and documents that building components and systems operate in accordance to the owner's project requirements and the project design documents.
- y. **Designer Final Inspection** is the inspection performed by the design team to determine the completeness of the project in accordance with approved plans and specifications. This inspection occurs prior to SCO final inspection.
- z. **SCO Final Inspection** is the inspection performed by the State Construction Office to determine the completeness of the project in accordance with NC Building Codes and approved plans and specifications.
- aa. **Beneficial Occupancy** is requested by the owner and is occupancy or partial occupancy of the building after all life safety items have been completed as determined by the State Construction Office. Life safety items include but not limited to fire alarm, sprinkler, egress and exit lighting, fire rated walls, egress paths and security.
- bb. Final Acceptance is the date in which the State Construction Office accepts the construction as totally complete. This includes the SCO Final Inspection and certification by the designer that all punch lists are completed.

ARTICLE 2 - INTENT AND EXECUTION OF DOCUMENTS

- a. The drawings and specifications are complementary, one to the other, and that which is shown on the drawings or called for in the specifications shall be as binding as if it were both called for and shown. The intent of the drawings and specifications is to establish the scope of all labor, materials, transportation, equipment, and any and all other things necessary to provide a bid for a complete job. In case of discrepancy or disagreement in the contract documents, the order of precedence shall be: Form of Contract, specifications, large-scale detail drawings, small-scale drawings.
- b. The wording of the specifications shall be interpreted in accordance with common usage of the language except that words having a commonly used technical or trade meaning shall be so interpreted in preference to other meanings.
- c. The contractor shall execute each copy of the proposal, contract, performance bond and payment bond as follows:
 - 1. If the documents are executed by a sole owner, that fact shall be evidenced by the word "Owner" appearing after the name of the person executing them.
 - 2. If the documents are executed by a partnership, that fact shall be evidenced by the word "Co-Partner" appearing after the name of the partner executing them.

3. If the documents are executed on the part of a corporation, they shall be executed by either the president or the vice president and attested by the secretary or assistant secretary in either case, and the title of the office of such persons shall appear after their signatures. The seal of the corporation shall be impressed on each signature page of the documents.
4. If the documents are made by a joint venture, they shall be executed by each member of the joint venture in the above form for sole owner, partnership or corporation, whichever form is applicable to each particular member.
5. All signatures shall be properly witnessed.
6. If the contractor's license is held by a person other than an owner, partner or officer of a firm, then the licensee shall also sign and be a party to the contract. The title "Licensee" shall appear under his/her signature.
7. The bonds shall be executed by an attorney-in-fact. There shall be attached to each copy of the bond a certified copy of power of attorney properly executed and dated.
8. Each copy of the bonds shall be countersigned by an authorized individual agent of the bonding company licensed to do business in North Carolina. The title "Licensed Resident Agent" shall appear after the signature.
9. The seal of the bonding company shall be impressed on each signature page of the bonds.
10. The contractor's signature on the performance bond and the payment bond shall correspond with that on the contract. The date of performance and payment bond shall not be prior to the date of the contract.

ARTICLE 3 - CLARIFICATIONS AND DETAIL DRAWINGS

- a. In such cases where the nature of the work requires clarification by the designer, such clarification shall be furnished by the designer with reasonable promptness by means of written instructions or detail drawings, or both. Clarifications and drawings shall be consistent with the intent of contract documents, and shall become a part thereof.
- b. The contractor(s) and the designer shall prepare, if deemed necessary, a schedule fixing dates upon which foreseeable clarifications will be required. The schedule will be subject to addition or change in accordance with progress of the work. The designer shall furnish drawings or clarifications in accordance with that schedule. The contractor shall not proceed with the work without such detail drawings and/or written clarifications.

ARTICLE 4 - COPIES OF DRAWINGS AND SPECIFICATIONS

The designer or Owner shall furnish free of charge to the contractors electronic copies of plans and specifications. If requested by the contractor, paper copies of plans and specifications shall be furnished free of charge as follows:

- a. General contractor - Up to twelve (12) sets of general contractor drawings and specifications, up to six (6) sets of which shall include drawings and specifications of all other contracts, plus a clean set of black line prints on white paper of all appropriate drawings, upon which the contractor shall clearly and legibly record all work-in-place that is at variance with the contract documents.

- b. Each other contractor - Up to six (6) sets of the appropriate drawings and specifications, up to three (3) sets of which shall include drawings and specifications of all other contracts, plus a clean set of black line prints on white paper of all appropriate drawings, upon which the contractor shall clearly and legibly record all work-in-place that is at variance with the contract documents.
- c. Additional sets shall be furnished at cost, including mailing, to the contractor upon request by the contractor. This cost shall be stated in the bidding documents.
- d. For the purposes of a single-prime contract, the contractor shall receive up to 30 sets of drawings and specifications, plus a clean set of black line prints on white paper of all appropriate drawings, upon which the contractor shall clearly and legibly record all work-in-place that is at variance with the contract documents.

ARTICLE 5 - SHOP DRAWINGS, SUBMITTALS, SAMPLES, DATA

- a. Within 15 consecutive calendar days after the notice to proceed, each prime contractor shall submit a schedule for submission of all shop drawings, product data, samples, and similar submittals through the Project Expediter to the Designer. This schedule shall indicate the items, relevant specification sections, other related submittal, data, and the date when these items will be furnished to the designer.
- b. The Contractor(s) shall review, approve and submit to the Designer all Shop Drawings, Coordination Drawings, Product Data, Samples, Color Charts, and similar submittal data required or reasonably implied by the Contract Documents. Required Submittals shall bear the Contractor's stamp of approval, any exceptions to the Contract Documents shall be noted on the submittals, and copies of all submittals shall be of sufficient quantity for the Designer to retain up to three (3) copies of each submittal for his own use plus additional copies as may be required by the Contractor. Submittals shall be presented to the Designer in accordance with the schedule submitted in paragraph (a). so as to cause no delay in the activities of the Owner or of separate Contractors.
- c. The Designer shall review required submittals promptly, noting desired corrections if any, and retaining three (3) copies (1 for the Designer, 1 for the owner and 1 for SCO) for his use. The remaining copies of each submittal shall be returned to the Contractor not later than twenty (20) days from the date of receipt by the Designer, for the Contractor's use or for corrections and resubmittal as noted by the Designer. When resubmittals are required, the submittal procedure shall be the same as for the original submittals.
- d. Approval of shop drawings/submittals by the Designer shall not be construed as relieving the Contractor from responsibility for compliance with the design or terms of the contract documents nor from responsibility of errors of any sort in the shop drawings, unless such lack of compliance or errors first have been called in writing to the attention of the Designer by the Contractor.

ARTICLE 6 - WORKING DRAWINGS AND SPECIFICATIONS AT THE JOB SITE

- a. The contractor shall maintain, in readable condition at his job office, one complete set of working drawings and specifications for his work including all shop drawings. Such drawings and specifications shall be available for use by the designer, his authorized representative, owner or State Construction Office.

- b. The contractor shall maintain at the job office, a day-to-day record of work-in-place that is at variance with the contract documents. Such variations shall be fully noted on project drawings by the contractor and submitted to the designer upon project completion and no later than 30 days after final acceptance of the project.
- c. The contractor shall maintain at the job office a record of all required tests that have been performed, clearly indicating the scope of work inspected and the date of approval or rejection.

ARTICLE 7 - OWNERSHIP OF DRAWINGS AND SPECIFICATIONS

All drawings and specifications are instruments of service and remain the property of the owner. The use of these instruments on work other than this contract without permission of the owner is prohibited. All copies of drawings and specifications other than contract copies shall be returned to the owner upon request after completion of the work.

ARTICLE 8 - MATERIALS, EQUIPMENT, EMPLOYEES

- a. The contractor shall, unless otherwise specified, supply and pay for all labor, transportation, materials, tools, apparatus, lights, power, heat, sanitary facilities, water, scaffolding and incidentals necessary for the completion of his work, and shall install, maintain and remove all equipment of the construction, other utensils or things, and be responsible for the safe, proper and lawful construction, maintenance and use of same, and shall construct in the best and most workmanlike manner, a complete job and everything incidental thereto, as shown on the plans, stated in the specifications, or reasonably implied therefrom, all in accordance with the contract documents.
- b. All materials shall be new and of quality specified, except where reclaimed material is authorized herein and approved for use. Workmanship shall at all times be of a grade accepted as the best practice of the particular trade involved, and as stipulated in written standards of recognized organizations or institutes of the respective trades except as exceeded or qualified by the specifications.
- c. Upon notice, the contractor shall furnish evidence as to quality of materials.
- d. Products are generally specified by ASTM or other reference standard and/or by manufacturer's name and model number or trade name. When specified only by reference standard, the Contractor may select any product meeting this standard, by any manufacturer. When several products or manufacturers are specified as being equally acceptable, the Contractor has the option of using any product and manufacturer combination listed. However, the contractor shall be aware that the cited examples are used only to denote the quality standard of product desired and that they do not restrict bidders to a specific brand, make, manufacturer or specific name; that they are used only to set forth and convey to bidders the general style, type, character and quality of product desired; and that equivalent products will be acceptable. Request for substitution of materials, items, or equipment shall be submitted to the designer for approval or disapproval; such approval or disapproval shall be made by the designer prior to the opening of bids. Alternate materials may be requested after the award if it can clearly be demonstrated that it is an added benefit to the owner and the designer and owner approves.
- e. The designer is the judge of equality for proposed substitution of products, materials or equipment.

- g. If at any time during the construction and completion of the work covered by these contract documents, the language, conduct, or attire of any workman of the various crafts be adjudged a nuisance to the owner or designer, or if any workman be considered detrimental to the work, the contractor shall order such parties removed immediately from grounds.

ARTICLE 9 - ROYALTIES, LICENSES AND PATENTS

It is the intention of the contract documents that the work covered herein will not constitute in any way infringement of any patent whatsoever unless the fact of such patent is clearly evidenced herein. The contractor shall protect and save harmless the owner against suit on account of alleged or actual infringement. The contractor shall pay all royalties and/or license fees required on account of patented articles or processes, whether the patent rights are evidenced hereinafter.

ARTICLE 10 - PERMITS, INSPECTIONS, FEES, REGULATIONS

- a. The contractor shall give all notices and comply with all laws, ordinances, codes, rules and regulations bearing on the conduct of the work under this contract. If the contractor observes that the drawings and specifications are at variance therewith, he shall promptly notify the designer in writing. See Instructions to Bidders, Paragraph 3, Bulletins and Addenda. Any necessary changes required after contract award shall be made by change order in accordance with Article 19. If the contractor performs any work knowing it to be contrary to such laws, ordinances, codes, rules and regulations, and without such notice to the designer, he shall bear all cost arising therefrom. Additional requirements implemented after bidding will be subject to equitable negotiations.
- b. All work under this contract shall conform to the North Carolina State Building Code and other State, local and national codes as are applicable. The cost of all required inspections and permits shall be the responsibility of the contractor and included within the bid proposal. All water taps, meter barrels, vaults and impact fees shall be paid by the contractor unless otherwise noted.
- d. Projects constructed by the State of North Carolina or by any agency or institution of the State are not subject to inspection by any county or municipal authorities and are not subject to county or municipal building codes. The contractor shall, however, cooperate with the county or municipal authorities by obtaining building permits. Permits shall be obtained at no cost.
- e. Projects involving local funding (community colleges) are subject also to county and municipal building codes and inspection by local authorities. The contractor shall pay the cost of these permits and inspections.

ARTICLE 11 - PROTECTION OF WORK, PROPERTY AND THE PUBLIC

- a. The contractors shall be jointly responsible for the entire site and the building or construction of the same and provide all the necessary protections, as required by the owner or designer, and by laws or ordinances governing such conditions. They shall be responsible for any damage to the owner's property, or of that of others on the job, by them, their personnel, or their subcontractors, and shall make good such damages. They shall be responsible for and pay for any damages caused to the owner. All contractors shall have access to the project at all times.
- b. The contractor shall provide cover and protect all portions of the structure when the work is not in progress, provide and set all temporary roofs, covers for doorways, sash and windows, and all other materials necessary to protect all the work on the building, whether set by him, or any of the subcontractors. Any work damaged through the lack of proper protection or from any other cause, shall be repaired or replaced without extra cost to the owner.
- c. No fires of any kind will be allowed inside or around the operations during the course of construction without special permission from the designer and owner.
- d. The contractor shall protect all trees and shrubs designated to remain in the vicinity of the operations by building substantial boxes around same. He shall barricade all walks, roads, etc., as directed by the designer to keep the public away from the construction. All trenches, excavations or other hazards in the vicinity of the work shall be well barricaded and properly lighted at night.
- e. The contractor shall provide all necessary safety measures for the protection of all persons on the job, including the requirements of the A.G.C. *Accident Prevention Manual in Construction*, as amended, and shall fully comply with all state laws or regulations and North Carolina State Building Code requirements to prevent accident or injury to persons on or about the location of the work. He shall clearly mark or post signs warning of hazards existing, and shall barricade excavations, elevator shafts, stairwells and similar hazards. He shall protect against damage or injury resulting from falling materials and he shall maintain all protective devices and signs throughout the progress of the work.
- f. The contractor shall adhere to the rules, regulations and interpretations of the North Carolina Department of Labor relating to Occupational Safety and Health Standards for the Construction Industry (Title 29, Code of Federal Regulations, Part 1926, published in Volume 39, Number 122, Part II, June 24, 1974, *Federal Register*), and revisions thereto as adopted by General Statutes of North Carolina 95-126 through 155.
- g. The contractor shall designate a responsible person of his organization as safety officer/inspector to inspect the project site for unsafe health and safety hazards, to report these hazards to the contractor for correction, and whose duties also include accident prevention on the project, and to provide other safety and health measures on the project site as required by the terms and conditions of the contract. The name of the safety inspector shall be made known to the designer and owner at the time of the preconstruction conference and in all cases prior to any work starting on the project.
- h. In the event of emergency affecting the safety of life, the protection of work, or the safety of adjoining properties, the contractor is hereby authorized to act at his own discretion, without further authorization from anyone, to prevent such threatened injury or damage.

Any compensation claimed by the contractor on account of such action shall be determined as provided for under Article 19(b).

- i. Any and all costs associated with correcting damage caused to adjacent properties of the construction site or staging area shall be borne by the contractor. These costs shall include but not be limited to flooding, mud, sand, stone, debris, and discharging of waste products.

ARTICLE 12 - SEDIMENTATION POLLUTION CONTROL ACT OF 1973

- a. Any land-disturbing activity performed by the contractor(s) in connection with the project shall comply with all erosion control measures set forth in the contract documents and any additional measures which may be required in order to ensure that the project is in full compliance with the Sedimentation Pollution Control Act of 1973, as implemented by Title 15, North Carolina Administrative Code, Chapter 4, Sedimentation Control, Subchapters 4A, 4B and 4C, as amended (15 N.C.A.C. 4A, 4B and 4C).
- b. Upon receipt of notice that a land-disturbing activity is in violation of said act, the contractor(s) shall be responsible for ensuring that all steps or actions necessary to bring the project in compliance with said act are promptly taken.
- c. The contractor(s) shall be responsible for defending any legal actions instituted pursuant to N.C.G.S. 113A-64 against any party or persons described in this article.
- d. To the fullest extent permitted by law, the contractor(s) shall indemnify and hold harmless the owner, the designer and the agents, consultants and employees of the owner and designer, from and against all claims, damages, civil penalties, losses and expenses, including, but not limited to, attorneys' fees, arising out of or resulting from the performance of work or failure of performance of work, provided that any such claim, damage, civil penalty, loss or expense is attributable to a violation of the Sedimentation Pollution Control Act. Such obligation shall not be construed to negate, abridge or otherwise reduced any other right or obligation of indemnity which would otherwise exist as to any party or persons described in this article.

ARTICLE 13 - INSPECTION OF THE WORK

- a. It is a condition of this contract that the work shall be subject to inspection during normal working hours and during any time work is in preparation and progress by the designer, designated official representatives of the owner, State Construction Office and those persons required by state law to test special work for official approval. The contractor shall therefore provide safe access to the work at all times for such inspections.
- b. All instructions to the contractor will be made only by or through the designer or his designated project representative. Observations made by official representatives of the owner shall be conveyed to the designer for review and coordination prior to issuance to the contractor.
- c. All work shall be inspected by designer, special inspector and/or State Construction Office prior to being covered by the contractor. Contractor shall give a minimum two weeks notice unless otherwise agreed to by all parties. If inspection fails, after the first reinspection all costs associated with additional reinspections shall be borne by the contractor.

- d. Where special inspection or testing is required by virtue of any state laws, instructions of the designer, specifications or codes, the contractor shall give adequate notice to the designer of the time set for such inspection or test, if the inspection or test will be conducted by a party other than the designer. Such special tests or inspections will be made in the presence of the designer, or his authorized representative, and it shall be the contractor's responsibility to serve ample notice of such tests.
- e. All laboratory tests shall be paid by the owner unless provided otherwise in the contract documents except the general contractor shall pay for laboratory tests to establish design mix for concrete, and for additional tests to prove compliance with contract documents where materials have tested deficient except when the testing laboratory did not follow the appropriate ASTM testing procedures.
- f. Should any work be covered up or concealed prior to inspection and approval by the designer, special inspector, and/or State Construction Office such work shall be uncovered or exposed for inspection, if so requested by the designer in writing. Inspection of the work will be made upon notice from the contractor. All cost involved in uncovering, repairing, replacing, recovering and restoring to design condition, the work that has been covered or concealed will be paid by the contractor involved.

ARTICLE 14 - CONSTRUCTION SUPERVISION AND SCHEDULE

- a. Throughout the progress of the work, each contractor shall keep at the job site, a competent superintendent and supervisory staff satisfactory to the designer and the owner. The superintendent and supervisory staff shall not be changed without the consent of the designer and owner unless said superintendent ceases to be employed by the contractor or ceases to be competent as determined by the contractor, designer or owner. The superintendent and other staff designated by the contractor in writing shall have authority to act on behalf of the contractor, and instructions, directions or notices given to him shall be as binding as if given to the contractor. However, directions, instructions, and notices shall be confirmed in writing.
- b. The contractor shall examine and study the drawings and specifications and fully understand the project design, and shall provide constant and efficient supervision to the work. Should he discover any discrepancies of any sort in the drawings or specifications, he shall report them to the designer without delay. He will not be held responsible for discrepancies in the drawings and/or specifications, but shall be held responsible to report them should they become known to him.
- c. All contractors shall be required to cooperate and consult with each other during the construction of this project. Prior to installation of work, all contractors shall jointly prepare coordination drawings, showing locations of various ductworks, piping, motors, pumps, and other mechanical or electrical equipment, in relation to the structure, walls and ceilings. These drawings shall be submitted to the designer through the Project Expediter for information only. Each contractor shall lay out and execute his work to cause the least delay to other contractors. Each contractor shall be financially responsible for any damage to other contractor's work and for undue delay caused to other contractors on the project.
- d. The contractor is required to attend job site progress conferences as called by the designer. The contractor shall be represented at these job progress conferences by both home office and project personnel. These representatives shall have authority to act on behalf of the contractor. These meetings shall be open to subcontractors, material

suppliers and any others who can contribute toward maintaining required job progress. It shall be the principal purpose of these meetings, or conferences, to effect coordination, cooperation and assistance in every practical way toward the end of maintaining progress of the project on schedule and to complete the project within the specified contract time. Each contractor shall be prepared to assess progress of the work as required in his particular contract and to recommend remedial measures for correction of progress as may be appropriate. The designer or his authorized representative shall be the coordinator of the conferences and shall preside as chairman. The contractor shall turn over a copy of his daily reports to the Designer and Owner at the job site progress conference. Owner will determine daily report format.

- e The contractor(s) shall, employ an engineer or a land surveyor licensed in the State of North Carolina to lay out the work and to establish a bench mark in a location where same will not be disturbed and where direct instruments sights may be taken.
- f. The designer shall designate a Project Expediter on projects involving two or more prime contracts. The Project Expediter shall be designated in the Supplementary General Conditions. The Project Expediter shall have at a minimum the following responsibilities.
 - 1. Prepare the project construction schedule and shall allow all prime contractors (multi-prime contract) and subcontractors (single-prime contract) performing general, plumbing, HVAC, and electrical work equal input into the preparation of the initial construction schedule.
 - 2. Maintain a project progress schedule for all contractors.
 - 3. Give adequate notice to all contractors to ensure efficient continuity of all phases of the work.
 - 4. Notify the designer of any changes in the project schedule.
 - 5. Recommend to the owner whether payment to a contractor shall be approved.
- g. It shall be the responsibility of the Project Expediter to cooperate with and obtain from several prime contractors and subcontractors on the job, their respective work activities and integrate these activities into a project construction schedule in form of a detailed bar chart or Critical Path Method (CPM), schedule. Each prime contractor shall provide work activities within fourteen (14) days of request by the Project Expediter. A “work activity”, for scheduling purposes, shall be any component or contractual requirement of the project requiring at least one (1) day, but not more than fourteen (14) days, to complete or fulfill. The project construction schedule shall graphically show all salient features of the work required to construct the project from start to finish and within the allotted time established in the contract. The time (in days) between the contractor’s early completion and contractual completion dates is part of the project total float time; and shall be used as such, unless amended by a change order. On a multi-prime project, each prime contractor shall review the proposed construction schedule and approve same in writing. The Project Expediter shall submit the proposed construction schedule to the designer for comments. The complete Project construction schedule shall be of the type set forth in the Supplementary General Condition or subparagraph (1) or (2) below, as appropriate:

1. For a project with total contracts of \$500,000 or less, a bar chart schedule will satisfy the above requirement. The schedule shall indicate the estimated starting and completion dates for each major element of the work.
2. For a project with total contracts over \$500,000, a Critical Path Method (CPM) schedule shall be utilized to control the planning and scheduling of the Work. The CPM schedule shall be the responsibility of the Project Expediter and shall be paid for by the Project Expediter.

Bar Chart Schedule: Where a bar chart schedule is required, it shall be time-scaled in weekly increments, shall indicate the estimated starting and completion dates for each major element of the work by trade and by area, level, or zone, and shall schedule dates for all salient features, including but not limited to the placing of orders for materials, submission of shop drawings and other Submittals for approval, approval of shop drawings by designers, the manufacture and delivery of material, the testing and the installation of materials, supplies and equipment, and all Work activities to be performed by the Contractor. The Contractor shall allow sufficient time in his schedule for all commissioning, required inspections and completion of final punchlist(s). Each Work activity will be assigned a time estimate by the Contractor. One day shall be the smallest time unit used.

CPM Schedule: Where a CPM schedule is required, it shall be in time-scaled precedence format using the Project Expediter's logic and time estimates. The CPM schedule shall be drawn or plotted with activities grouped or zoned by Work area or subcontract as opposed to a random (or scattered) format. The CPM schedule shall be time-scaled on a weekly basis and shall be drawn or plotted at a level of detail and logic which will schedule all salient features of the work to be performed by the Contractor. The Contractor shall allow sufficient time in his schedule for all commissioning, required inspections and completion of final punchlist(s).. Each Work activity will be assigned a time estimate by the Contractor. One day shall be the smallest time unit used.

The CPM schedule will identify and describe each activity, state the duration of each activity, the calendar dates for the early and late start and the early and late finish of each activity, and clearly highlight all activities on the critical path. "Total float" and "free float" shall be indicated for all activities. Float time shall not be considered for the exclusive use or benefit of either the Owner or the Contractor, but must be allocated in the best interest of completing the Work within the Contract time. Extensions to the Contract time, when granted by Change Order, will be granted only when equitable time adjustment exceeds the Total Float in the activity or path of activities affected by the change. On contracts with a price over \$2,500,000, the CPM schedule shall also show what part of the Contract Price is attributable to each activity on the schedule, the sum of which for all activities shall equal the total Contract Price.

Early Completion of Project: The Contractor may attempt to complete the project prior to the Contract Completion Date. However, such planned early completion shall be for the Contractor's convenience only and shall not create any additional rights of the Contractor or obligations of the Owner under this Contract, nor shall it change the Time

for Completion or the Contract Completion Date. The Contractor shall not be required to pay liquidated damages to the Owner because of its failure to complete by its planned earlier date. Likewise, the Owner shall not pay the Contractor any additional compensation for early completion nor will the Owner owe the Contractor any compensation should the Owner, its officers, employees, or agents cause the Contractor not to complete earlier than the date required by the Contract Documents.

- h. The proposed project construction schedule shall be presented to the designer no later than fifteen (15) days after written notice to proceed. No application for payment will be processed until this schedule is accepted by the designer and owner.
- i. The approved project construction schedule shall be distributed to all contractors and displayed at the job site by the Project Expediter.
- j. The several contractors shall be responsible for their work activities and shall notify the Project Expediter of any necessary changes or adjustments to their work. The Project Expediter shall maintain the project construction schedule, making biweekly adjustments, updates, corrections, etc., that are necessary to finish the project within the Contract time, keeping all contractors and the designer fully informed. Copy of a bar chart schedule annotated to show the current progress shall be submitted by the Contractor(s) to the designer, along with monthly request for payment. For project requiring CPM schedule, the Contractor shall submit a biweekly report of the status of all activities. The bar chart schedule or status report shall show the actual Work completed to date in comparison with the original Work scheduled for all activities. If any activities of the work of several contractors are behind schedule, the contractor must indicate in writing, what measures will be taken to bring each such activity back on schedule and to ensure that the Contract Completion Date is not exceeded. A plan of action and recovery schedule shall be developed and submitted to the designer by the Project Expediter, when (1) the contractor's report indicates delays, that are in the opinion of the designer or the owner, of sufficient magnitude that the contractor's ability to complete the work by the scheduled completion is brought into question; (2) the updated construction schedule is thirty (30) days behind the planned or baseline schedule and no legitimate time extensions, as determined by the Designer, are in process; and (3) the contractor desires to make changes in the logic (sequencing of work) or the planned duration of future activities of the CPM schedule which, in the opinion of the designer or the owner, are of a major nature. The plan of action, when required shall be submitted to the Owner for review within two (2) business days of the Contractor receiving the Owner's written demand. The recovery schedule, when required, shall be submitted to the Owner within five (5) calendar days of the Contractor's receiving the Owner's written demand. Failure to provide an updated construction schedule or a recovery schedule may be grounds for rejection of payment applications or withholding of funds as set forth in Article 33.
- k. The Project Expediter shall notify each contractor of such events or time frames that are critical to the progress of the job. Such notice shall be timely and reasonable. Should the progress be delayed due to the work of any of the several contractors, it shall be the duty of the Project Expediter to immediately notify the contractor(s) responsible for such delay, the designer, the State Construction Office and other prime contractors. The designer shall determine the contractor(s) who caused the delays and notify the bonding company of the responsible contractor(s) of the delays; and shall make a recommendation to the owner regarding further action.
- l. Designation as Project Expediter entails an additional project control responsibility and does not alter in any way the responsibility of the contractor so designated, nor the

responsibility of the other contractors involved in the project. The project expeditor's Superintendent(s) shall be in attendance at the Project site at all times when work is in progress unless conditions are beyond the control of the Contractor or until termination of the Contract in accordance with the Contract Documents. It is understood that such Superintendent shall be acceptable to the Owner and Designer and shall be the one who will be continued in that capacity for the duration of the project unless he ceases to be on the Contractor's payroll or the Owner otherwise agrees. The Superintendent shall not be employed on any other project for or by the Contractor or by any other entity during the course of the Work. If the Superintendent is employed by the Contractor on another project without the Owner's approval, then the Owner may deduct from the Contractor's monthly general condition costs and amount representing the Superintendent's cost and shall deduct that amount for each month thereafter until the Contractor has the Superintendent back on the Owner's Project full-time.

ARTICLE 15 - SEPARATE CONTRACTS AND CONTRACTOR RELATIONSHIPS

- a. Effective from January 1, 2002, Chapter 143, Article 8, was amended, to allow public contracts to be delivered by the following delivery methods: single-prime, dual (single-prime and separate-prime), construction manager at risk, and alternative contracting method as approved by the State Building Commission. The owner reserves the right to prepare separate specifications, receive separate bids, and award separate contracts for such other major items of work as may be in the best interest of the State. For the purposes of a single prime contract, refer to Article 1 – Definitions.
- b. All contractors shall cooperate with each other in the execution of their work, and shall plan their work in such manner as to avoid conflicting schedules or delay of the work. See Article 14, Construction Supervision.
- c. If any part of contractor's work depends upon the work of another contractor, defects which may affect that work shall be reported to the designer in order that prompt inspection may be made and the defects corrected. Commencement of work by a contractor where such condition exists will constitute acceptance of the other contractor's work as being satisfactory in all respects to receive the work commenced, except as to defects which may later develop. The designer shall be the judge as to the quality of work and shall settle all disputes on the matter between contractors.
- d. Any mechanical or electrical work such as sleeves, inserts, chases, openings, penetrations, etc., which is located in the work of the general contractor shall be built in by the general contractor. The respective mechanical and electrical contractors shall set all sleeves, inserts and other devices that are to be incorporated into the structure in cooperation and under the supervision of the general contractor. The responsibility for the exact location of such items shall be that of the mechanical and/or electrical contractor.
- e. The designer and the owner shall have access to the work whenever it is in preparation and progress and during normal working hours. The contractor shall provide facilities for such access so the designer may perform his functions under the contract documents.
- f. Should a contractor cause damage to the work or property of another contractor, he shall be directly responsible, and upon notice, shall promptly settle the claim or otherwise resolve the dispute.

ARTICLE 16 - SUBCONTRACTS AND SUBCONTRACTORS

- a. Within thirty (30) days after award of the contract, the contractor shall submit to the designer, owner and to the State Construction Office a list giving the names and addresses of subcontractors and equipment and material suppliers he proposes to use, together with the scope of their respective parts of the work. Should any subcontractor be disapproved by the designer or owner, the designer or owner shall submit his reasons for disapproval in writing to the State Construction Office for its consideration with a copy to the contractor. If the State Construction Office concurs with the designer's or owner's recommendation, the contractor shall submit a substitute for approval. The designer and owner shall act promptly in the approval of subcontractors, and when approval of the list is given, no changes of subcontractors will be permitted except for cause or reason considered justifiable by the designer or owner.
- b. The designer will furnish to any subcontractor, upon request, evidence regarding amounts of money paid to the contractor on account of the subcontractor's work.
- c. The contractor is and remains fully responsible for his own acts or omissions as well as those of any subcontractor or of any employee of either. The contractor agrees that no contractual relationship exists between the subcontractor and the owner in regard to the contract, and that the subcontractor acts on this work as an agent or employee of the contractor.
- d. The owner reserves the right to limit the amount of portions of work to be subcontracted as hereinafter specified.

ARTICLE 17 - CONTRACTOR AND SUBCONTRACTOR RELATIONSHIPS

The contractor agrees that the terms of these contract documents shall apply equally to each subcontractor as to the contractor, and the contractor agrees to take such action as may be necessary to bind each subcontractor to these terms. The contractor further agrees to conform to the Code of Ethical Conduct as adopted by the Associated General Contractors of America, Inc., with respect to contractor-subcontractor relationships, and that payments to subcontractors shall be made in accordance with the provisions of G.S. 143-134.1 titled Interest on final payments due to prime contractors: payments to subcontractors.

- a. On all public construction contracts which are let by a board or governing body of the state government or any political subdivision thereof, except contracts let by the Department of Transportation pursuant to G.S. 136-28.1, the balance due prime contractors shall be paid in full within 45 days after respective prime contracts of the project have been accepted by the owner, certified by the architect, engineer or designer to be completed in accordance with terms of the plans and specifications, or occupied by the owner and used for the purpose for which the project was constructed, whichever occurs first. Provided, however, that whenever the architect or consulting engineer in charge of the project determines that delay in completion of the project in accordance with terms of the plans and specifications is the fault of the contractor, the project may be occupied and used for the purposes for which it was constructed without payment of any interest on amounts withheld past the 45 day limit. No payment shall be delayed because of the failure of another prime contractor on such project to complete his contract. Should final payment to any prime contractor beyond the date such contracts have been certified to be completed by the designer or architect, accepted by the owner, or occupied by the owner and used for the purposes for which the project was constructed, be delayed by more than 45 days, said prime contractor shall be paid interest, beginning on the 46th day, at the rate of one percent (1%) per month or fraction thereof unless a lower rate is

agreed upon on such unpaid balance as may be due. In addition to the above final payment provisions, periodic payments due a prime contractor during construction shall be paid in accordance with the payment provisions of the contract documents or said prime contractor shall be paid interest on any such unpaid amount at the rate stipulated above for delayed final payments. Such interest shall begin on the date the payment is due and continue until the date on which payment is made. Such due date may be established by the terms of the contract. Funds for payment of such interest on state-owned projects shall be obtained from the current budget of the owning department, institution or agency. Where a conditional acceptance of a contract exists, and where the owner is retaining a reasonable sum pending correction of such conditions, interest on such reasonable sum shall not apply.

- b. Within seven days of receipt by the prime contractor of each periodic or final payment, the prime contractor shall pay the subcontractor based on work completed or service provided under the subcontract. Should any periodic or final payment to the subcontractor be delayed by more than seven days after receipt of periodic or final payment by the prime contractor, the prime contractor shall pay the subcontractor interest, beginning on the eighth day, at the rate of one percent (1%) per month or fraction thereof on such unpaid balance as may be due.
- c. The percentage of retainage on payments made by the prime contractor to the subcontractor shall not exceed the percentage of retainage on payments made by the owner to the prime contractor. Any percentage of retainage on payments made by the prime contractor to the subcontractor that exceeds the percentage of retainage on payments made by the owner to the prime contractor shall be subject to interest to be paid by the prime contractor to the subcontractor at the rate of one percent (1%) per month or fraction thereof.
- d. Nothing in this section shall prevent the prime contractor at the time of application and certification to the owner from withholding application and certification to the owner for payment to the subcontractor for unsatisfactory job progress; defective construction not remedied; disputed work; third-party claims filed or reasonable evidence that claim will be filed; failure of subcontractor to make timely payments for labor, equipment and materials; damage to prime contractor or another subcontractor; reasonable evidence that subcontract cannot be completed for the unpaid balance of the subcontract sum; or a reasonable amount for retainage not to exceed the initial percentage retained by owner.

ARTICLE 18 - DESIGNER'S STATUS

- a. The designer shall provide general administration of the performance of construction contracts, including liaison and necessary inspection of the work to ensure compliance with plans and specifications. He is the agent of the owner only for the purpose of constructing this work and to the extent stipulated in the contract documents. He has authority to direct work to be performed, to stop work, to order work removed, or to order corrections of faulty work, where any such action by the designer may be necessary to assure successful completion of the work.
- b. The designer is the impartial interpreter of the contract documents, and, as such, he shall exercise his powers under the contract to enforce faithful performance by both the owner and the contractor, taking sides with neither.
- c. Should the designer cease to be employed on the work for any reason whatsoever, then the owner shall employ a competent replacement who shall assume the status of the former designer.

- d. The designer and his consultants will make inspections of the project. He will inspect the progress, the quality and the quantity of the work.
- e. The designer and the owner shall have access to the work whenever it is in preparation and progress during normal working hours. The contractor shall provide facilities for such access so the designer and owner may perform their functions under the contract documents.
- f. Based on the designer's inspections and evaluations of the project, the designer shall issue interpretations, directives and decisions as may be necessary to administer the project. His decisions relating to artistic effect and technical matters shall be final, provided such decisions are within the limitations of the contract.

ARTICLE 19 - CHANGES IN THE WORK

- a. The owner may have changes made in the work covered by the contract. These changes will not invalidate and will not relieve or release the contractor from any guarantee given by him pertinent to the contract provisions. These changes will not affect the validity of the guarantee bond and will not relieve the surety or sureties of said bond. All extra work shall be executed under conditions of the original contract.
- b. Except in an emergency endangering life or property, no change shall be made by the contractor except upon receipt of approved change order or written field order from the designer, countersigned by the owner and the state construction office authorizing such change. No claim for adjustments of the contract price shall be valid unless this procedure is followed.

A field order, transmitted by fax, electronically, or hand delivered, may be used where the change involved impacts the critical path of the work. A formal change order shall be issued as expeditiously as possible.

In the event of emergency endangering life or property, the contractor may be directed to proceed on a time and material basis whereupon the contractor shall proceed and keep accurately on such form as specified by the designer or owner, a correct account of costs together with all proper invoices, payrolls and supporting data. Upon completion of the work the change order will be prepared as outlined under either Method "c(1)" or Method "c(2)" or both.

- c. In determining the values of changes, either additive or deductive, contractors are restricted to the use of the following methods:
 - 1. Where the extra work involved is covered by unit prices quoted in the proposal, or subsequently agreed to by the Contractor, Designer, Owner and State Construction Office the value of the change shall be computed by application of unit prices based on quantities, estimated or actual as agreed of the items involved, except in such cases where a quantity exceeds the estimated quantity allowance in the contract by one hundred percent (100%) or more. In such cases, either party may elect to proceed under subparagraph c2 herein. If neither party elects to proceed under c2, then unit prices shall apply.
 - 2. The contracting parties shall negotiate and agree upon the equitable value of the change prior to issuance of the change order, and the change order shall stipulate the corresponding lump sum adjustment to the contract price.

- d. Under Paragraph "b" and Methods "c(2)" above, the allowances for overhead and profit combined shall be as follows: all contractors (the single contracting entity (prime), his subcontractors(1st tier subs), or their sub-subcontractors (2nd tier subs, 3rd tier subs, etc)) shall be allowed a maximum of 10% on work they each self-perform; the prime contractor shall be allowed a maximum of 5% on contracted work of his 1st tier sub; 1st tier, 2nd tier, 3rd tier, etc contractors shall be allowed a maximum of 2.5% on the contracted work of their subs. ; Under Method "c(1)", no additional allowances shall be made for overhead and profit. In the case of deductible change orders, under Method "c(2)" and Paragraph (b) above, the contractor shall include no less than five percent (5%) profit, but no allowances for overhead.
- e. The term "net cost" as used herein shall mean the difference between all proper cost additions and deductions. The "cost" as used herein shall be limited to the following:
1. The actual costs of materials and supplies incorporated or consumed as part of the work;
 2. The actual costs of labor expended on the project site; labor expended in coordination, change order negotiation, record document maintenance, shop drawing revision or other tasks necessary to the administration of the project are considered overhead whether they take place in an office or on the project site.
 3. The actual costs of labor burden, limited to the costs of social security (FICA) and Medicare/Medicaid taxes; unemployment insurance costs; health/dental/vision insurance premiums; paid employee leave for holidays, vacation, sick leave, and/or petty leave, not to exceed a total of 30 days per year; retirement contributions; worker's compensation insurance premiums; and the costs of general liability insurance when premiums are computed based on payroll amounts; the total of which shall not exceed thirty percent (30%) of the actual costs of labor;
 4. The actual costs of rental for tools, excluding hand tools; equipment; machinery; and temporary facilities required for the work;
 5. The actual costs of premiums for bonds, insurance, permit fees, and sales or use taxes related to the work.

Overtime and extra pay for holidays and weekends may be a cost item only to the extent approved by the owner.

- f. Should concealed conditions be encountered in the performance of the work below grade, or should concealed or unknown conditions in an existing structure be at variance with the conditions indicated by the contract documents, the contract sum and time for completion may be equitably adjusted by change order upon claim by either party made within thirty (30) days after the condition has been identified. The cost of such change shall be arrived at by one of the foregoing methods. All change orders shall be supported by a unit cost breakdown showing method of arriving at net cost as defined above.
- g. In all change orders, the procedure will be for the designer to request proposals for the change order work in writing. The contractor will provide such proposal and supporting data in suitable format. The designer shall verify correctness. Delay in the processing of the change order due to lack of proper submittal by the contractor of all required supporting data shall not constitute grounds for a time extension or basis of a claim. Within fourteen (14) days after receipt of the contractor's accepted proposal including all supporting documentation required by the designer, the designer shall prepare the change order and forward to the contractor for his signature or otherwise respond, in writing, to

the contractor's proposal. Within seven (7) days after receipt of the change order executed by the contractor, the designer shall, certify the change order by his signature, and forward the change order and all supporting data to the owner for the owner's signature. The owner shall execute the change order and forward to the State Construction Office for final approval, within seven (7) days of receipt. The State Construction Office shall act on the change order within seven (7) days. In case of emergency or extenuating circumstances, approval of changes may be obtained verbally by telephone or field orders approved by all parties, then shall be substantiated in writing as outlined under normal procedure.

- h. At the time of signing a change order, the contractor shall be required to certify as follows:

"I certify that my bonding company will be notified forthwith that my contract has been changed by the amount of this change order, and that a copy of the approved change order will be mailed upon receipt by me to my surety."

- i. A change order, when issued, shall be full compensation, or credit, for the work included, omitted or substituted. It shall show on its face the adjustment in time for completion of the project as a result of the change in the work.
- j. If, during the progress of the work, the owner requests a change order and the contractor's terms are unacceptable, the owner, with the approval of the State Construction Office, may require the contractor to perform such work on a time and material basis whereupon the contractor shall proceed and keep accurately on such form as specified by the Designer or owner, a correct account of cost together with all proper invoices, payrolls and supporting data. Upon completion of the work a change order will be prepared with allowances for overhead and profit per paragraph d. above and "net cost" and "cost" per paragraph e. above. Without prejudice, nothing in this paragraph shall preclude the owner from performing or to have performed that portion of the work requested in the change order.

ARTICLE 20 - CLAIMS FOR EXTRA COST

- a. Should the contractor consider that as a result of instructions given by the designer, he is entitled to extra cost above that stated in the contract, he shall give written notice thereof to the designer within seven (7) days without delay. The written notice shall clearly state that a claim for extra cost is being made and shall provide a detailed justification for the extra cost. The contractor shall not proceed with the work affected until further advised, except in emergency involving the safety of life or property, which condition is covered in Article 19(b) and Article 11(h). No claims for extra compensation shall be considered unless the claim is so made. The designer shall render a written decision within seven (7) days of receipt of claim.
- b. The contractor shall not act on instructions received by him from persons other than the designer, and any claims for extra compensation or extension of time on account of such instruction will not be honored. The designer shall not be responsible for misunderstandings claimed by the contractor of verbal instructions which have not been confirmed in writing, and in no case shall instructions be interpreted as permitting a departure from the contract documents unless such instruction is confirmed in writing and supported by a properly authorized change order.
- c. Should a claim for extra compensation that complies with the requirements of (a) above by the contractor and is denied by the designer or owner, and cannot be resolved by a

representative of the State Construction Office, the contractor may request a mediation in connection with GS 143-128(f1) in the dispute resolution rules adopted by the State Building Commission (1 N.C.A.C. 30H .0101 through .1001). If the contractor is unable to resolve its claim as a result of mediation, the contractor may pursue the claim in accordance with the provisions of G.S. 143-135.3, or G.S. 143-135.6 where Community Colleges are the owner, and the following:

1. A contractor who has not completed a contract with a board for construction or repair work and who has not received the amount he claims is due under the contract may submit a verified written claim to the director of the State Construction Office of the Department of Administration for the amount the contractor claims is due. The director may deny, allow or compromise the claim, in whole or in part. A claim under this subsection is not a contested case under Chapter 150B of the General Statutes.
2. (a) A contractor who has completed a contract with a board for construction or repair work and who has not received the amount he claims is due under the contract may submit a verified written claim to the director of the State Construction Office of the Department of Administration for the amount the contractor claims is due. The claim shall be submitted within sixty (60) days after the contractor receives a final statement of the board's disposition of his claim and shall state the factual basis for the claim.
 - (b) The director shall investigate a submitted claim within ninety (90) days of receiving the claim, or within any longer time period upon which the director and the contractor agree. The contractor may appear before the director, either in person or through counsel, to present facts and arguments in support of his claim. The director may allow, deny or compromise the claim, in whole or in part. The director shall give the contractor a written statement of the director's decision on the contractor's claim.
 - (c) A contractor who is dissatisfied with the director's decision on a claim submitted under this subsection may commence a contested case on the claim under Chapter 150B of the General Statutes. The contested case shall be commenced within sixty (60) days of receiving the director's written statement of the decision.
 - (d) As to any portion of a claim that is denied by the director, the contractor may, in lieu of the procedures set forth in the preceding subsection of this section, within six (6) months of receipt of the director's final decision, institute a civil action for the sum he claims to be entitled to under the contract by filing a verified complaint and the issuance of a summons in the Superior Court of Wake County or in the superior court of any county where the work under the contract was performed. The procedure shall be the same as in all civil actions except that all issues shall be tried by the judge, without a jury.

ARTICLE 21 - MINOR CHANGES IN THE WORK

The designer will have the authority to order minor changes in the work not involving an adjustment in the contract sum or time for completion, and not inconsistent with the intent of the contract documents. Such changes shall be effected by written order, copied to the State Construction Office, and shall be binding on the owner and the contractor.

ARTICLE 22 - UNCORRECTED FAULTY WORK

Should the correction of faulty or damaged work be considered inadvisable or inexpedient by the owner and the designer, the owner shall be reimbursed by the contractor. A change order will be issued to reflect a reduction in the contract sum.

ARTICLE 23 - TIME OF COMPLETION, DELAYS, EXTENSION OF TIME

- a. The time of completion is stated in the Supplementary General Conditions and in the Form of Construction Contract. The Project Expediter, upon notice of award of contract, shall prepare a construction schedule to complete the project within the time of completion as required by Article 14.
- b. The contractors shall commence work to be performed under this agreement on a date to be specified in a written Notice to Proceed from the designer and shall fully complete all work hereunder within the time of completion stated. Time is of the essence and the contractor acknowledges the Owner will likely suffer financial damage for failure to complete the work within the time of completion. For each day in excess of the above number of days, the contractor(s) shall pay the owner the sum stated as liquidated damages reasonably estimated in advance to cover the losses to be incurred by the owner by reason of failure of said contractor(s) to complete the work within the time specified, such time being in the essence of this contract and a material consideration thereof. Should the work be delayed by both the owner and contractor, liquidated damages shall be apportioned to reflect the delays of each party. In the case of concurrent delays, contractor caused delays shall be accounted for before owner and designer caused delays.
- c. In the event of multiple prime contractors, the designer shall be the judge as to the division of responsibility between the contractor(s), based on the construction schedule, weekly reports and job records, and shall apportion the amount of liquidated damages to be paid by each of them, according to delay caused by any or all of them.
- d. If the contractor is delayed at any time in the progress of his work solely by any act or negligence of the owner, the designer, or by any employee of either; by any separate contractor employed by the owner; by changes ordered in the work; by labor disputes at the project site; by abnormal weather conditions not reasonably anticipated for the locality where the work is performed; by unavoidable casualties; by any causes beyond the contractor's control; or by any other causes which the designer and owner determine may justify the delay, then the contract time may be extended by change order only for the time which the designer and owner may determine is reasonable.

Time extensions will not be granted for rain, wind, snow or other natural phenomena of normal intensity for the locality where work is performed. For purpose of determining extent of delay attributable to unusual weather phenomena, a determination shall be made by comparing the weather for the contract period involved with the average of the preceding five (5) year climatic range during the same time interval based on the National Oceanic and Atmospheric Administration National Weather Service statistics for the locality where work is performed and on daily weather logs kept on the job site by the contractor reflecting the effect of the weather on progress of the work and initialed by the designer's representative. No weather delays shall be considered after the building is dried in unless work claimed to be delayed is on the critical path of the baseline schedule or approved updated schedule. Time extensions for weather delays, acts of God, labor disputes, fire, delays in transportation, unavoidable casualties or other delays which are beyond the control of the Owner do not entitle the Contractor to compensable damages for delays. Any contractor claim for compensable damages for delays is limited to delays caused solely by the owner or its agents. Contractor caused delays shall be accounted for before owner or designer caused delays in the case of concurrent delays.

- e. Request for extension of time shall be made in writing to the designer, copies to the owner and SCO, within twenty (20) days following cause of delay. In case of continuing cause for delay, the Contractor shall notify the Designer to the designer, copies to the owner and SCO, of the delay within 20 days of the beginning of the delay and only one claim is necessary.
- f. The contractor shall notify his surety in writing of extension of time granted.
- g. No claim for time extension shall be allowed on account of failure of the designer to furnish drawings or instructions until twenty (20) days after demand for such drawings and/or instructions. See Article 5c. Demand must be in written form clearly stating the potential for delay unless the drawings or instructions are provided. Any delay granted will begin after the twenty (20) day demand period is concluded.

ARTICLE 24 - PARTIAL UTILIZATION/BENEFICIAL OCCUPANCY

- a. The owner may desire to occupy or utilize all or a portion of the project prior to the completion of the project.
- b. Should the owner request a utilization of a building or portion thereof, the designer shall perform a designer final inspection of area after being notified by the contractor that the area is ready for such. After the contractor has completed designer final inspection punch list and the designer has verified, then the designer shall schedule a beneficial occupancy inspection at a time and date acceptable to the owner, contractor(s) and State Construction Office. If beneficial occupancy is granted by the State Construction Office, in such areas the following will be established:
 - 1. The beginning of guarantees and warranties period for the equipment necessary to support. in the area.
 - 2. The owner assumes all responsibilities for utility costs for entire building.
 - 2. Contractor will obtain consent of surety.
 - 3. Contractor will obtain endorsement from insurance company permitting beneficial occupancy.
- c. The owner shall have the right to exclude the contractor from any part of the project which the designer has so certified to be substantially complete, but the owner will allow the contractor reasonable access to complete or correct work to bring it into compliance with the contract.
- d. Occupancy by the owner under this article will in no way relieve the contractor from his contractual requirement to complete the project within the specified time. The contractor will not be relieved of liquidated damages because of beneficial occupancy. The designer may prorate liquidated damages based on the percentage of project occupied.

ARTICLE 25 - FINAL INSPECTION, ACCEPTANCE, AND PROJECT CLOSEOUT

- a. Upon notification from the contractor(s) that the project is complete and ready for inspection, the designer shall make a Designer final inspection to verify that the project is complete and ready for SCO final inspection. Prior to SCO final inspection, the contractor(s) shall complete all items requiring corrective measures noted at the Designer

final inspection. The designer shall schedule a SCO final inspection at a time and date acceptable to the owner, contractor(s) and State Construction Office.

- b. At the SCO final inspection, the designer and his consultants shall, if job conditions warrant, record a list of items that are found to be incomplete or not in accordance with the contract documents. At the conclusion of the SCO final inspection, the designer and State Construction Office representative shall make one of the following determinations:
 - 1. That the project is completed and accepted.
 - 2. That the project will be accepted subject to the correction of the list of discrepancies (punch list). All punch list items must be completed within thirty (30) days of SCO final inspection or the owner may invoke Article 28, Owner's Right to Do Work.
 - 4. That the project is not complete and another date for a SCO final inspection will be established.
- c. Within fourteen (14) days of final acceptance per Paragraph b1 or within fourteen (14) days after completion of punch list per Paragraph b2 above, the designer shall certify the work and issue applicable certificate(s) of compliance.
- d. Any discrepancies listed or discovered after the date of SCO final inspection and acceptance under Paragraphs b1 or b2 above shall be handled in accordance with Article 42, Guarantee.
- f. The final acceptance date will establish the following:
 - 1. The beginning of guarantees and warranties period.
 - 2. The date on which the contractor's insurance coverage for public liability, property damage and builder's risk may be terminated.
 - 3. That no liquidated damages (if applicable) shall be assessed after this date.
 - 4. The termination date of utility cost to the contractor.
- g. **Prior to issuance of final acceptance date, the contractor shall have his authorized representatives visit the project and give full instructions to the designated personnel regarding operating, maintenance, care, and adjustment of all equipment and special construction elements. In addition, the contractor shall provide to the owner a complete instructional video (media format acceptable to the owner) on the operation, maintenance, care and adjustment of all equipment and special construction elements.**

ARTICLE 26 - CORRECTION OF WORK BEFORE FINAL PAYMENT

- a. Any work, materials, fabricated items or other parts of the work which have been condemned or declared not in accordance with the contract by the designer shall be promptly removed from the work site by the contractor, and shall be immediately replaced by new work in accordance with the contract at no additional cost to the owner. Work or property of other contractors or the owner, damaged or destroyed by virtue of such faulty work, shall be made good at the expense of the contractor whose work is faulty.

- b. Correction of condemned work described above shall commence within twenty-four (24) hours after receipt of notice from the designer, and shall make satisfactory progress, as determined by the designer, until completed.
- c. Should the contractor fail to proceed with the required corrections, then the owner may complete the work in accordance with the provisions of Article 28.

ARTICLE 27 - CORRECTION OF WORK AFTER FINAL PAYMENT

See Article 35, Performance Bond and Payment Bond, and Article 42, Guarantee. Neither the final certificate, final payment, occupancy of the premises by the owner, nor any provision of the contract, nor any other act or instrument of the owner, nor the designer, shall relieve the contractor from responsibility for negligence, or faulty material or workmanship, or failure to comply with the drawings and specifications. Contractor shall correct or make good any defects due thereto and repair any damage resulting there from, which may appear during the guarantee period following final acceptance of the work except as stated otherwise under Article 42, Guarantee. The owner will report any defects as they may appear to the contractor and establish a time limit for completion of corrections by the contractor. The owner will be the judge as to the responsibility for correction of defects.

ARTICLE 28 - OWNER'S RIGHT TO DO WORK

If, during the progress of the work or during the period of guarantee, the contractor fails to prosecute the work properly or to perform any provision of the contract, the owner, after seven (7) days' written notice sent by certified mail, return receipt requested, to the contractor from the designer, may perform or have performed that portion of the work. The cost of the work may be deducted from any amounts due or to become due to the contractor, such action and cost of same having been first approved by the designer. Should the cost of such action of the owner exceed the amount due or to become due the contractor, then the contractor or his surety, or both, shall be liable for and shall pay to the owner the amount of said excess.

ARTICLE 29 - ANNULMENT OF CONTRACT

If the contractor fails to begin the work under the contract within the time specified, or the progress of the work is not maintained on schedule, or the work is not completed within the time above specified, or fails to perform the work with sufficient workmen and equipment or with sufficient materials to ensure the prompt completion of said work, or shall perform the work unsuitably or shall discontinue the prosecution of the work, or if the contractor shall become insolvent or be declared bankrupt or commit any act of bankruptcy or insolvency, or allow any final judgment to stand against him unsatisfied for a period of forty-eight (48) hours, or shall make an assignment for the benefit of creditors, or for any other cause whatsoever shall not carry on the work in an acceptable manner, the owner may give notice in writing, sent by certified mail, return receipt requested, to the contractor and his surety of such delay, neglect or default, specifying the same, and if the contractor within a period of seven (7) days after such notice shall not proceed in accordance therewith, then the owner shall, declare this contract in default, and, thereupon, the surety shall promptly take over the work and complete the performance of this contract in the manner and within the time frame specified. In the event the surety shall fail to take over the work to be done under this contract within seven (7) days after being so notified and notify the owner in writing, sent by certified mail, return receipt requested, that he is taking the same over and stating that he will diligently pursue and complete the same, the owner shall have full power and authority, without violating the contract, to take the prosecution of the work out of the hands of said contractor, to appropriate or use any or all contract materials and equipment on the grounds as may be suitable and acceptable and may enter into an agreement, either by public letting or negotiation, for the completion of said contract according to the terms and provisions thereof

or use such other methods as in his opinion shall be required for the completion of said contract in an acceptable manner. All costs and charges incurred by the owner, together with the costs of completing the work under contract, shall be deducted from any monies due or which may become due said contractor and surety. In case the expense so incurred by the owner shall be less than the sum which would have been payable under the contract, if it had been completed by said contractor, then the said contractor and surety shall be entitled to receive the difference, but in case such expense shall exceed the sum which would have been payable under the contract, then the contractor and the surety shall be liable and shall pay to the owner the amount of said excess.

ARTICLE 30 - CONTRACTOR'S RIGHT TO STOP WORK OR TERMINATE THE CONTRACT

- a. Should the work be stopped by order of a court having jurisdiction, or by order of any other public authority for a period of three months, due to cause beyond the fault or control of the contractor, or if the owner should fail or refuse to make payment on account of a certificate issued by the designer within forty-five (45) days after receipt of same, then the contractor, after fifteen (15) days' written notice sent by certified mail, return receipt requested, to the owner and the designer, may suspend operations on the work or terminate the contract.
- b. The owner shall be liable to the contractor for the cost of all materials delivered and work performed on this contract plus 10 percent overhead and profit and shall make such payment. The designer shall be the judge as to the correctness of such payment.

ARTICLE 31 - REQUEST FOR PAYMENT

- a. Not later than the fifth day of the month, the contractor shall submit to the designer a request for payment for work done during the previous month. The request shall be in the form agreed upon between the contractor and the designer, but shall show substantially the value of work done and materials delivered to the site during the period since the last payment, and shall sum up the financial status of the contract with the following information:
 1. Total of contract including change orders.
 2. Value of work completed to date.
 3. Less five percent (5%) retainage, provided however, that after fifty percent (50%) of the contractor's work has been satisfactorily completed on schedule, with approval of the owner and the State Construction Office and written consent of the surety, further requirements for retainage will be waived only so long as work continues to be completed satisfactorily and on schedule.
 4. Less previous payments.
 5. Current amount due.
- b. The contractor, upon request of the designer, shall substantiate the request with invoices of vouchers or payrolls or other evidence.
- c. Prior to submitting the first request, the contractor shall prepare for the designer a schedule showing a breakdown of the contract price into values of the various parts of the work, so arranged as to facilitate payments to subcontractors in accordance with Article 17, Contractor and Subcontractor Relationships. The contractor(s) shall list the

value of each subcontractor and supplier, identifying each minority business subcontractor and supplier as listed in Affidavit C, if applicable.

- d. When payment is made on account of stored materials and equipment, such materials must be stored on the owner's property, and the requests for payments shall be accompanied by invoices or bills of sale or other evidence to establish the owner's title to such materials and equipment. Such payments will be made only for materials that have been customized or fabricated specifically for this project. Raw materials or commodity products including but not limited to piping, conduit, CMU, metal studs and gypsum board may not be submitted. Responsibility for such stored materials and equipment shall remain with the contractor regardless of ownership title. Such stored materials and equipment shall not be removed from the owner's property. Should the space for storage on-site be limited, the contractor, at his option, shall be permitted to store such materials and/or equipment in a suitable space off-site. Should the contractor desire to include any such materials or equipment in his application for payment, they must be stored in the name of the owner in an independent, licensed, bonded warehouse approved by the designer, owner and the State Construction Office and located as close to the site as possible. The warehouse selected must be approved by the contractor's bonding and insurance companies; the material to be paid for shall be assigned to the owner and shall be inspected by the designer. Upon approval by the designer, owner and SCO of the storage facilities and materials and equipment, payment therefore will be certified. Responsibility for such stored materials and equipment shall remain with the contractor. Such stored materials and equipment shall not be moved except for transportation to the project site. Under certain conditions, the designer may approve storage of materials at the point of manufacture, which conditions shall be approved by the designer, the owner and the State Construction Office prior to approval for the storage and shall include an agreement by the storing party which unconditionally gives the State absolute right to possession of the materials at anytime. Bond, security and insurance protection shall continue to be the responsibility of the contractor(s).
- e. In the event of beneficial occupancy, retainage of funds due the contractor(s) may be reduced with the approval of the State Construction Office to an equitable amount to cover the list of items to be completed or corrected. Retainage may not be reduced to less than two and one-half (2 1/2) times the estimated value of the work to be completed or corrected. Reduction of retainage must be with the consent and approval of the contractor's bonding company.

ARTICLE 32 - CERTIFICATES OF PAYMENT AND FINAL PAYMENT

- a. Within five (5) days from receipt of request for payment from the contractor, the designer shall issue and forward to the owner a certificate for payment. This certificate shall indicate the amount requested or as approved by the designer. If the certificate is not approved by the designer, he shall state in writing to the contractor and the owner his reasons for withholding payment.
- b. No certificate issued or payment made shall constitute an acceptance of the work or any part thereof. The making and acceptance of final payment shall constitute a waiver of all claims by the owner except:
 - 1. Claims arising from unsettled liens or claims against the contractor.
 - 2. Faulty work or materials appearing after final payment.
 - 3. Failure of the contractor to perform the work in accordance with drawings and specifications, such failure appearing after payment.

4. As conditioned in the performance bond and payment bond.
- c. The making and acceptance of final payment shall constitute a waiver of all claims by the contractor except those claims previously made and remaining unsettled (Article 20(c)).
- d. Prior to submitting request for final payment to the designer for approval, the contractor shall fully comply with all requirements specified in the “ project closeout” section of the specifications. These requirements include but not limited to the following:
 1. Submittal of Product and Operating Manuals, Warranties and Bonds, Guarantees, Maintenance Agreements, As-Built Drawings, Certificates of Inspection or Approval from agencies having jurisdiction. (The designer must approve the Manuals prior to delivery to the owner).
 2. Transfer of Required attic stock material and all keys in an organized manner.
 3. Record of Owner’s training.
 4. Resolution of any final inspection discrepancies.
 5. Granting access to Contractor’s records, if Owner’s internal auditors have made a request for such access pursuant to Article 52.
- e. The contractor shall forward to the designer, the final application for payment along with the following documents:
 1. List of minority business subcontractors and material suppliers showing breakdown of contract amounts and total actual payments to subs and material suppliers.
 2. Affidavit of Release of Liens.
 3. Affidavit of contractors of payment to material suppliers and subcontractors. (See Article 36).
 4. Consent of Surety to Final Payment.
 5. Certificates of state agencies required by state law.
- f. The designer will not authorize final payment until the work under contract has been certified by designer, certificates of compliance issued, and the contractor has complied with the closeout requirements. The designer shall forward the contractor’s final application for payment to the owner along with respective certificate(s) of compliance required by law.

ARTICLE 33 - PAYMENTS WITHHELD

- a. The designer with the approval of the State Construction Office may withhold payment for the following reasons:
 1. Faulty work not corrected.

2. The unpaid balance on the contract is insufficient to complete the work in the judgment of the designer.
 3. To provide for sufficient contract balance to cover liquidated damages that will be assessed.
- b. The secretary of the Department of Administration may authorize the withholding of payment for the following reasons:
 1. Claims filed against the contractor or evidence that a claim will be filed.
 2. Evidence that subcontractors have not been paid.
 - c. The Owner may withhold all or a portion of Contractor's general conditions costs set forth in the approved schedule of values, if Contractor has failed to comply with: (1) a request to access its records by Owner's internal auditors pursuant to Article 52; (2) a request for a plan of action and/or recovery schedule under Article 14.j or provide The Owner; (3) a request to provide an electronic copies of Contractor's baseline schedule, updates with all logic used to create the schedules in the original format of the scheduling software; and (4) Contractor's failure to have its Superintendent on the Project full-time; (
 - d. When grounds for withholding payments have been removed, payment will be released. Delay of payment due the contractor without cause will make owner liable for payment of interest to the contractor in accordance with G.S. 143-134.1. As provided in G.S.143-134.1(e) the owner shall not be liable for interest on payments withheld by the owner for unsatisfactory job progress, defective construction not remedied, disputed work, or third-party claims filed against the owner or reasonable evidence that a third-party claim will be filed.

ARTICLE 34 - MINIMUM INSURANCE REQUIREMENTS

The work under this contract shall not commence until the contractor has obtained all required insurance and verifying certificates of insurance have been approved in writing by the owner. These certificates shall document that coverages afforded under the policies will not be cancelled, reduced in amount or coverages eliminated until at least thirty (30) days after mailing written notice, by certified mail, return receipt requested, to the insured and the owner of such alteration or cancellation. If endorsements are needed to comply with the notification or other requirements of this article copies of the endorsements shall be submitted with the certificates.

a. Worker's Compensation and Employer's Liability

The contractor shall provide and maintain, until final acceptance, workmen's compensation insurance, as required by law, as well as employer's liability coverage with minimum limits of \$100,000.

b. Public Liability and Property Damage

The contractor shall provide and maintain, until final acceptance, comprehensive general liability insurance, including coverage for premises operations, independent contractors, completed operations, products and contractual exposures, as shall protect such contractors from claims arising out of any bodily injury, including accidental death, as well as from claims for property damages which may arise from operations under this contract, whether such operations be by the contractor or by any subcontractor, or by

anyone directly or indirectly employed by either of them and the minimum limits of such insurance shall be as follows:

Bodily Injury: \$500,000 per occurrence
Property Damage: \$100,000 per occurrence / \$300,000 aggregate

In lieu of limits listed above, a \$500,000 combined single limit shall satisfy both conditions.

Such coverage for completed operations must be maintained for at least two (2) years following final acceptance of the work performed under the contract.

c. Property Insurance (Builder's Risk/Installation Floater)

The contractor shall purchase and maintain property insurance until final acceptance, upon the entire work at the site to the full insurable value thereof. This insurance shall include the interests of the owner, the contractor, the subcontractors and sub-subcontractors in the work and shall insure against the perils of fire, wind, rain, flood, extended coverage, and vandalism and malicious mischief. If the owner is damaged by failure of the contractor to purchase or maintain such insurance, then the contractor shall bear all reasonable costs properly attributable thereto; the contractor shall effect and maintain similar property insurance on portions of the work stored off the site when request for payment per articles so includes such portions.

d. Deductible

Any deductible, if applicable to loss covered by insurance provided, is to be borne by the contractor.

e. Other Insurance

The contractor shall obtain such additional insurance as may be required by the owner or by the General Statutes of North Carolina including motor vehicle insurance, in amounts not less than the statutory limits.

f. Proof of Carriage

The contractor shall furnish the owner with satisfactory proof of carriage of the insurance required before written approval is granted by the owner.

ARTICLE 35 - PERFORMANCE BOND AND PAYMENT BOND

- a. Each contractor shall furnish a performance bond and payment bond executed by a surety company authorized to do business in North Carolina. The bonds shall be in the full contract amount. Bonds shall be executed in the form bound with these specifications.
- b. All bonds shall be countersigned by an authorized agent of the bonding company who is licensed to do business in North Carolina.

ARTICLE 36 - CONTRACTOR'S AFFIDAVIT

The final payment of retained amount due the contractor on account of the contract shall not become due until the contractor has furnished to the owner through the designer an affidavit signed, sworn and notarized to the effect that all payments for materials, services or subcontracted work in connection with his contract have been satisfied, and that no claims or

liens exist against the contractor in connection with this contract. In the event that the contractor cannot obtain similar affidavits from subcontractors to protect the contractor and the owner from possible liens or claims against the subcontractor, the contractor shall state in his affidavit that no claims or liens exist against any subcontractor to the best of his (the contractor's) knowledge, and if any appear afterward, the contractor shall save the owner harmless.

ARTICLE 37 - ASSIGNMENTS

The contractor shall not assign any portion of this contract nor subcontract in its entirety. Except as may be required under terms of the performance bond or payment bond, no funds or sums of money due or become due the contractor under the contract may be assigned.

ARTICLE 38 - USE OF PREMISES

- a. The contractor(s) shall confine his apparatus, the storage of materials and the operations of his workmen to limits indicated by law, ordinances, permits or directions of the designer and owner and shall not exceed those established limits in his operations.
- b. The contractor(s) shall not load or permit any part of the structure to be loaded with a weight that will endanger its safety.
- c. The contractor(s) shall enforce the designer's and owner's instructions regarding signs, advertisements, fires and smoking.
- d. No firearms, any type of alcoholic beverages, or drugs (other than those prescribed by a physician) will be permitted at the job site.

ARTICLE 39 - CUTTING, PATCHING AND DIGGING

- a. The contractor shall do all cutting, fitting or patching of his work that may be required to make its several parts come together properly and fit it to receive or be received by work of other contractors shown upon or reasonably implied by the drawings and specifications for the completed structure, as the designer may direct.
- b. Any cost brought about by defective or ill-timed work shall be borne by the party responsible therefor.
- c. No contractor shall endanger any work of another contractor by cutting, digging or other means. No contractor shall cut or alter the work of any other contractor without the consent of the designer and the affected contractor(s).

ARTICLE 40 - UTILITIES, STRUCTURES, SIGNS

- a. The contractor shall provide necessary and adequate facilities for water, electricity, gas, oil, sewer and other utility services which maybe necessary and required for completion of the project including all utilities required for testing, cleaning, balancing, and sterilization of designated plumbing, mechanical and electrical systems. Any permanent meters installed shall be listed in the contractor's name until work has a final acceptance. The contractor will be solely responsible for all utility costs prior to final acceptance. Contractor shall contact all affected utility companies prior to bid to determine their requirements to provide temporary and permanent service and include all costs associated with providing those services in their bid. Coordination of the work of the utility companies during construction is the sole responsibility of the contractor.

- b. Meters shall be relisted in the owner's name on the day following final acceptance of the Project Expediter's work, and the owner shall pay for services used after that date.
- c. The owner shall be reimbursed for all metered utility charges after the meter is relisted in the owner's name and prior to completion and acceptance of the work of **all** contractors. Reimbursement shall be made by the contractor whose work has not been completed and accepted. If the work of two or more contractors has not been completed and accepted, reimbursement to the owner shall be paid by the contractors involved on the basis of assessments by the designer.
- d. Prior to the operation of permanent systems, the Project Expediter will provide temporary power, lighting, water, and heat to maintain space temperature above freezing, as required for construction operations.
- e. All contractors shall have the permanent building systems in sufficient readiness for furnishing temporary climatic control at the time a building is enclosed and secured. The HVAC systems shall maintain climatic control throughout the enclosed portion of the building sufficient to allow completion of the interior finishes of the building. A building shall be considered enclosed and secured when windows, doorways (exterior, mechanical, and electrical equipment rooms), and hardware are installed; and other openings have protection which will provide reasonable climatic control. The appropriate time to start the mechanical systems and climatic condition shall be jointly determined by the contractor(s), the designer and owner. Use of the equipment in this manner shall be subject to the approval of the Designer and owner and shall in no way affect the warranty requirements of the contractor(s).
- f. The electrical contractor shall have the building's permanent power wiring distribution system in sufficient readiness to provide power as required by the HVAC contractor for temporary climatic control.
- g. The electrical contractor shall have the building's permanent lighting system ready at the time the general contractor begins interior painting and shall provide adequate lighting in those areas where interior painting and finishing is being performed.
- h. Each prime contractor shall be responsible for his permanently fixed service facilities and systems in use during progress of the work. The following procedures shall be strictly adhered to:
 - 1. Prior to final acceptance of work by the State Construction Office, each contractor shall remove and replace any parts of the permanent building systems damaged through use during construction.
 - 2. Temporary filters as recommended by the equipment manufacturer in order to keep the equipment and ductwork clean and free of dust and debris shall be installed in each of the heating and air conditioning units and at each return grille during construction. New filters shall be installed in each unit prior to the owner's acceptance of the work.
 - 3. Extra effort shall be maintained to keep the building and the site adjacent to the building clean and under no circumstances shall air systems be operated if finishing and site work operations are creating dust in excess of what would be considered normal if the building were occupied.
 - 4. It shall be understood that any warranty on equipment presented to the owner shall extend from the day of final acceptance by the owner. The cost of warranting the

equipment during operation in the finishing stages of construction shall be borne by the contractor whose system is utilized.

5. The electrical contractor shall have all lamps in proper working condition at the time of final project acceptance.
 - i. The Project Expediter shall provide, if required and where directed, a shed for toilet facilities and shall furnish and install in this shed all water closets required for a complete and adequate sanitary arrangement. These facilities will be available to other contractors on the job and shall be kept in a neat and sanitary condition at all times. Chemical toilets are acceptable.
 - j. The Project Expediter shall, if required by the Supplementary General Conditions and where directed, erect a temporary field office, complete with lights, telephone, heat and air conditioning. A portion of this office shall be partitioned off, of sufficient size, for the use of a resident inspector, should the designer so direct.
 - k. On multi-story construction projects, the Project Expediter shall provide temporary elevators, lifts, or other special equipment for the general use of all contractors. The cost for such elevators, lifts or other special equipment and the operation thereof shall be included in the Project Expediter's bid.
 - l. The Project Expediter will erect one sign on the project if required. The sign shall be of sound construction, and shall be neatly lettered with black letters on white background. The sign shall bear the name of the project, and the names of prime contractors on the project, and the name of the designer and consultants. Directional signs may be erected on the owner's property subject to approval of the owner with respect to size, style and location of such directional signs. Such signs may bear the name of the contractor and a directional symbol. No other signs will be permitted except by permission of the owner.

ARTICLE 41 - CLEANING UP

- a. The contractors shall keep the building and surrounding area reasonably free from rubbish at all times, and shall remove debris from the site on a timely basis or when directed to do so by the designer or Project Expediter. The Project Expediter shall provide an on site refuse container(s) for the use of all contractors. Each contractor shall remove their rubbish and debris from the building on a daily basis. The Project Expediter shall broom clean the building as required to minimize dust and dirt accumulation.
- b. The Project Expediter shall provide and maintain suitable all-weather access to the building.
- c. Before final inspection and acceptance of the building, each contractor shall clean his portion of the work, including glass, hardware, fixtures, masonry, tile and marble (using no acid), clean and wax all floors as specified, and completely prepare the building for use by the owner, with no cleaning required by the owner.

ARTICLE 42 - GUARANTEE

- a. The contractor shall unconditionally guarantee materials and workmanship against patent defects arising from faulty materials, faulty workmanship or negligence for a period of twelve (12) months following the date of final acceptance of the work or beneficial occupancy and shall replace such defective materials or workmanship without cost to the owner.

- b. Where items of equipment or material carry a manufacturer's warranty for any period in excess of twelve (12) months, then the manufacturer's warranty shall apply for that particular piece of equipment or material. The contractor shall replace such defective equipment or materials, without cost to the owner, within the manufacturer's warranty period.
- c. Additionally, the owner may bring an action for latent defects caused by the negligence of the contractor which is hidden or not readily apparent to the owner at the time of beneficial occupancy or final acceptance, whichever occurred first, in accordance with applicable law.
- d. Guarantees for roof, equipment, materials, and supplies shall be stipulated in the specifications sections governing such roof, equipment, materials, or supplies.

ARTICLE 43 - CODES AND STANDARDS

Wherever reference is given to codes, standard specifications or other data published by regulating agencies including, but not limited to, national electrical codes, North Carolina state building codes, federal specifications, ASTM specifications, various institute specifications, etc., it shall be understood that such reference is to the latest edition including addenda published prior to the date of the contract documents.

ARTICLE 44 - INDEMNIFICATION

To the fullest extent permitted by law, the contractor shall indemnify and hold harmless the owner, the designer and the agents, consultants and employees of the owner and designer, from and against all claims, damages, losses and expenses, including, but not limited to, attorneys' fees, arising out of or resulting from the performance or failure of performance of the work, provided that any such claim, damage, loss or expense (1) is attributable to bodily injury, sickness, disease or death, or to injury to or destruction of tangible property (other than the work itself) including the loss of use resulting there from, and (2) is caused in whole or in part by any negligent act or omission of the contractor, the contractor's subcontractor, or the agents of either the contractor or the contractor's subcontractor. Such obligation shall not be construed to negate, abridge or otherwise reduce any other right or obligation of indemnity which would otherwise exist as to any party or person described in this article.

ARTICLE 45 - TAXES

- a. Federal excise taxes do not apply to materials entering into state work (Internal Revenue Code, Section 3442(3)).
- b. Federal transportation taxes do not apply to materials entering into state work (Internal Revenue Code, Section 3475(b) as amended).
- c. North Carolina sales tax and use tax, as required by law, do apply to materials entering into state work and such costs shall be included in the bid proposal and contract sum.
- d. Local option sales and use taxes, as required by law, do apply to materials entering into state work as applicable and such costs shall be included in the bid proposal and contract sum.
- e. **Accounting Procedures for Refund of County Sales & Use Tax**

Amount of county sales and use tax paid per contractor's statements:

Contractors performing contracts for state agencies shall give the state agency for whose project the property was purchased a signed statement containing the information listed in G.S. 105-164.14(e).

The Department of Revenue has agreed that in lieu of obtaining copies of sales receipts from contractors, an agency may obtain a certified statement as of April 1, 1991 from the contractor setting forth the date, the type of property and the cost of the property purchased from each vendor, the county in which the vendor made the sale and the amount of local sales and use taxes paid thereon. If the property was purchased out-of-state, the county in which the property was delivered should be listed. The contractor should also be notified that the certified statement may be subject to audit.

In the event the contractors make several purchases from the same vendor, such certified statement must indicate the invoice numbers, the inclusive dates of the invoices, the total amount of the invoices, the counties, and the county sales and use taxes paid thereon.

Name of taxing county: The position of a sale is the retailer's place of business located within a taxing county where the vendor becomes contractually obligated to make the sale. Therefore, it is important that the county tax be reported for the county of sale rather than the county of use.

When property is purchased from out-of-state vendors and the county tax is charged, the county should be identified where delivery is made when reporting the county tax.

Such statement must also include the cost of any tangible personal property withdrawn from the contractor's warehouse stock and the amount of county sales or use tax paid thereon by the contractor.

Similar certified statements by his subcontractors must be obtained by the general contractor and furnished to the claimant.

Contractors are not to include any tax paid on supplies, tools and equipment which they use to perform their contracts and should include only those building materials, supplies, fixtures and equipment which actually become a part of or annexed to the building or structure.

ARTICLE 46 - EQUAL OPPORTUNITY CLAUSE

The non-discrimination clause contained in Section 202 (Federal) Executive Order 11246, as amended by Executive Order 11375, relative to equal employment opportunity for all persons without regard to race, color, religion, sex or national origin, and the implementing rules and regulations prescribed by the secretary of Labor, are incorporated herein.

ARTICLE 47 - EMPLOYMENT OF INDIVIDUALS WITH DISABILITIES

The contractor(s) agree not to discriminate against any employee or applicant for employment because of physical or mental disabilities in regard to any position for which the employee or applicant is qualified. The contractor agrees to take affirmative action to employ, advance in employment and otherwise treat qualified individuals with such disabilities without discrimination based upon their physical or mental disability in all employment practices.

ARTICLE 48 - ASBESTOS-CONTAINING MATERIALS (ACM)

The State of North Carolina has attempted to address all asbestos-containing materials that are to be disturbed in the project. However, there may be other asbestos-containing materials in the work areas that are not to be disturbed and do not create an exposure hazard.

Contractors are reminded of the requirements of instructions under Instructions to Bidders and General Conditions of the Contract, titled Examination of Conditions. Statute 130A, Article 19, amended August 3, 1989, established the Asbestos Hazard Management Program that controls asbestos abatement in North Carolina. The latest edition of *Guideline Criteria for Asbestos Abatement* from the State Construction Office is to be incorporated in all asbestos abatement projects for the Capital Improvement Program.

ARTICLE 49 - MINORITY BUSINESS PARTICIPATION

GS 143-128.2 establishes a ten percent (10%) goal for participation by minority businesses in total value of work for each State building project. The document, *Guidelines for Recruitment and Selection of Minority Businesses for Participation in State Construction Contracts* including Affidavits and Appendix E are hereby incorporated into and made a part of this contract.

ARTICLE 50 – CONTRACTOR EVALUATION

The contractor's overall work performance on the project shall be fairly evaluated in accordance with the State Building Commission policy and procedures, for determining qualifications to bid on future State capital improvement projects. In addition to final evaluation, interim evaluation may be prepared during the progress of project. The document, *Contractor Evaluation Procedures*, is hereby incorporated and made a part of this contract. The owner may request the contractor's comments to evaluate the designer.

ARTICLE 51 – GIFTS

Pursuant to N.C. Gen. Stat. § 133-32, it is unlawful for any vendor or contractor (i.e. architect, bidder, contractor, construction manager, design professional, engineer, subcontractor, supplier, vendor, etc.), to make gifts or to give favors to any State employee. This prohibition covers those vendors and contractors who: (1) have a contract with a governmental agency; or (2) have performed under such a contract within the past year; or (3) anticipate bidding on such a contract in the future. For additional information regarding the specific requirements and exemptions, vendors and contractors are encouraged to review G.S. Sec. 133-32.

During the construction of the Project, the Contractor is prohibited from making gifts to any of the Owner's employees, Owner's project representatives (architect, engineers, construction manager and their employees), employees of the State Construction Office and/or any other State employee that may have any involvement, influence, responsibilities, oversight, management and/or duties that pertain to and/or relate to the contract administration, financial administration and/or disposition of claims arising from and/or relating to the Contract and/or Project.

ARTICLE 52 – AUDITING-ACCESS TO PERSONS AND RECORDS

In accordance with N.C. General Statute 147-64.7, the State Auditor shall have access to Contractor's officers, employees, agents and/or other persons in control of and/or responsible for the Contractor's records that relate to this Contracts for purposes of conducting audits under the referenced statute. The Owner's internal auditors shall also have the right to access and copy the Contractor's records relating to the Contract and Project during the term of the Contract and within two years following the completion of the Project/close-out of the Contract to verify accounts, accuracy, information, calculations and/or data affecting and/or

relating to Contractor's requests for payment, requests for change orders, change orders, claims for extra work, requests for time extensions and related claims for delay/extended general conditions costs, claims for lost productivity, claims for loss efficiency, claims for idle equipment or labor, claims for price/cost escalation, pass-through claims of subcontractors and/or suppliers, and/or any other type of claim for payment or damages from Owner and/or its project representatives.

ARTICLE 53 – NORTH CAROLINA FALSE CLAIMS ACT

The North Carolina False Claims Act ("NCFCA"), N.C. Gen. Stat. § 1-605 through 1-618, applies to this Contract. The Contractor should familiarize itself with the entire NCFCA and should seek the assistance of an attorney if it has any questions regarding the NCFCA and its applicability to any requests, demands and/or claims for payment its submits to the State through the contracting state agency, institution, university or community college.

The purpose of the NCFCA "is to deter persons from knowingly causing or assisting in causing the State to pay claims that are false or fraudulent and to provide remedies in the form of treble damages and civil penalties when money is obtained from the State by reason of a false or fraudulent claim." (Section 1-605(b).) A contractor's liability under the NCFCA may arise from, but is not limited to: requests for payment, invoices, billing, claims for extra work, requests for change orders, requests for time extensions, claims for delay damages/extended general conditions costs, claims for lost productivity, claims for loss efficiency, claims for idle equipment or labor, claims for price/cost escalation, pass-through claims of subcontractors and/or suppliers, documentation used to support any of the foregoing requests or claims, and/or any other request for payment from the State through the contracting state agency, institution, university or community college. The parts of the NCFCA that are most likely to be enforced with respect to this type of contract are as follows:

- A "claim" is "[a]ny request or demand, whether under a contract or otherwise, for money or property and whether or not the State has title to the money or property that (i) is presented to an officer, employee, or agent of the State or (ii) is made to a contractor ... if the money or property is to be spent or used on the State's behalf or to advance a State program or interest and if the State government: (a) provides or has provided any portion of the money or property that is requested or demanded; or (b) will reimburse such contractor ... for any portion of the money or property which is requested or demanded." (Section 1-606(2).)
- "Knowing" and "knowingly." – Whenever a person, with respect to information, does any of the following: (a) Has actual knowledge of the information; (b) Acts in deliberate ignorance of the truth or falsity of the information; and/or (c) Acts in reckless disregard of the truth or falsity of the information. (Section 1-606(4).) Proof of specific intent to defraud is not required. (Section 1-606(4).)
- "Material" means having a natural tendency to influence, or be capable of influencing, the payment or receipt of money or property. (Section 1-606(4).)
- Liability. – "Any person who commits any of the following acts shall be liable to the State for three times the amount of damages that the State sustains because of the act of that person[:] ... (1) Knowingly presents or causes to be presented a false or fraudulent claim for payment or approval. (2) Knowingly makes, uses, or causes to be made or used, a false record or statement material to a false or fraudulent claim. (3) Conspires to commit a violation of subdivision (1), (2) ..." (Section 1-607(a)(1), (2).)

- The NCFCA shall be interpreted and construed so as to be consistent with the federal False Claims Act, 31 U.S.C. § 3729, et seq., and any subsequent amendments to that act. (Section 1-616(c).)

Finally, the contracting state agency, institution, university or community college may refer any suspected violation of the NCFCA by the Contractor to the Attorney General's Office for investigation. Under Section 1-608(a), the Attorney General is responsible for investigating any violation of NCFCA, and may bring a civil action against the Contractor under the NCFCA. The Attorney General's investigation and any civil action relating thereto are independent and not subject to any dispute resolution provision set forth in this Contract. (See Section 1-608(a).)

ARTICLE 54 – TERMINATION FOR CONVENIENCE

Owner may at any time and for any reason terminate Contractor's services and work at Owner's convenience. Upon receipt of such notice, Contractor shall, unless the notice directs otherwise, immediately discontinue the work and placing of orders for materials, facilities and supplies in connection with the performance of this Agreement.

Upon such termination, Contractor shall be entitled to payment only as follows: (1) the actual cost of the work completed in conformity with this Agreement; plus, (2) such other costs actually incurred by Contractor as are permitted by the prime contract and approved by Owner; (3) plus ten percent (10%) of the cost of the work referred to in subparagraph (1) above for overhead and profit. There shall be deducted from such sums as provided in this subparagraph the amount of any payments made to Contractor prior to the date of the termination of this Agreement. Contractor shall not be entitled to any claim or claim of lien against Owner for any additional compensation or damages in the event of such termination and payment.

THIS DOCUMENT MODIFIES THE REVISED JANUARY 2013 – 24th EDITION OF FORM OC-15, GENERAL CONDITIONS OF THE CONTRACT.

SUPPLEMENTARY GENERAL CONDITIONS

ARTICLE 2, INTENT AND EXECUTION OF DOCUMENTS

Add to paragraph “a.”

Drawings Bowman Murray Hemingway Architects, PC, Woods Engineering, PA, CBHF Engineers, PLLC, and Tripp Engineering, PC, labeled Learning Resources Center Renovation and dated November 25, 2024, and Project Manual dated November 25, 2024.

Index of Drawings

G1.0 COVER SHEET
G1.1 BUILDING DATA/APPENDIX B
G1.2 FIRST AND SECOND FLOOR LIFE SAFETY PLANS

CIVIL:

C1 DEMO PLAN
C2 SITE, GRADING, DRAINAGE, EROSION CONTROL AND STORMWATER MANAGEMENT PLAN

ARCHITECTURAL:

D1.0 DEMOLITION FLOOR PLANS
D1.1 DEMOLITION ELEVATIONS
D1.2 DEMOLITION REFLECTED CEILING PLANS

A1.0 ARCHITECTURAL SITE PLAN
A1.1 ENLARGED ARCHITECTURAL SITE PLAN AND DETAILS
A2.0 FIRST FLOOR RENOVATION PLAN
A2.1 SECOND FLOOR RENOVATION PLAN
A3.0 EXTERIOR ELEVATIONS
A4.0 SECTIONS AND DETAILS
A4.1 SECTIONS AND DETAILS
A5.0 ENLARGED STAIR PLAN & DETAILS
A5.1 ENLARGED PLANS AND DETAILS
A5.2 MILLWORK ELEVATIONS AND DETAILS
A5.3 MILLWORK ELEVATIONS AND DETAILS
A6.0 DOOR SCHEDULE AND ROOM FINISH SCHEDULES
A6.1 DOOR AND WINDOW FRAME ELEVATIONS
A6.2 DOOR FRAME DETAILS
A6.3 WINDOW FRAME DETAILS
A7.0 RENOVATION REFLECTED CEILING PLANS
A8.0 ROOF PLAN

STRUCTURAL:

S1.01	GENERAL NOTES
S1.02	GENERAL NOTES
S1.03	TYPICAL DETAILS
S2.01	FIRST FLOOR STRUCTURAL RENOVATION PLAN
S2.02	SECOND FLOOR STRUCTURAL RENOVATION PLAN
S3.01	SECTIONS & DETAILS
S3.02	FOUNDATION SECTIONS
S4.01	GRADE BEAM AND CMU DETAILS

PLUMBING:

P0.1	PLUMBING GENERAL NOTES, LEGEND, ABBREVIATIONS
P0.2	PLUMBING SCHEDULE AND DETAILS
PD1.1	PLUMBING DEMOLITION FIRST FLOOR PLAN - WASTE-VENT
PD2.1	PLUMBING DEMOLITION FIRST FLOOR PLAN - DOMESTIC WATER
P1.1	PLUMBING FIRST FLOOR WASTE-VENT PLANS
P2.1	PLUMBING FIRST FLOOR DOMESTIC WATER AND FUEL GAS PIPING PLANS

MECHANICAL :

M0.1	MECHANICAL SUMMARIES, NOTES, LEGEND AND ABBREVIATIONS
MD1.1	MECHANICAL DEMOLITION FIRST FLOOR PLAN - HVAC
MD1.2	MECHANICAL DEMOLITION FIRST FLOOR PLAN - HYDRONIC
MD4.1	MECHANICAL DEMOLITION ENLARGED PLANS
MH1.1	MECHANICAL FIRST FLOOR PLAN - HVAC
MH1.2	MECHANICAL FIRST FLOOR PLAN - CONDENSATE PIPING
MP1.1	MECHANICAL FIRST FLOOR PLAN - HYDRONIC
MP4.1	MECHANICAL PARTIAL FIRST FLOOR PLAN - HYDRONIC
M4.1	MECHANICAL ENLARGED PLANS
M5.1	MECHANICAL DETAILS
M5.2	MECHANICAL DETAILS AND SCHEDULE
M6.1	MECHANICAL SCHEDULES
M6.2	MECHANICAL SCHEDULES
M6.3	MECHANICAL SCHEDULES
M7.1	MECHANICAL CONTROLS
M7.2	MECHANICAL CONTROLS

- M7.3 MECHANICAL PIPING AND CONTROL SCHEMATIC - DEMOLITION
- M7.4 MECHANICAL PIPING AND CONTROL SCHEMATIC

ELECTRICAL:

- E-0.1 ELECTRICAL ABBREVIATIONS AND LEGEND
- E-0.2 ELECTRICAL SELECTIVE DEMOLITION NOTES
- E-0.3 ELECTRICAL GENERAL NOTES
- E-0.4 ELECTRICAL POWER RISER DIAGRAM AND DETAILS
- E-0.4A ELECTRICAL ALTERNATE BID #2 POWER RISER DIAGRAM
DETAILS
- E-0.5 ELECTRICAL LOAD SUMMARY AND PANEL SCHEDULES
- E-0.6 ELECTRICAL DETAILS
- E-0.7 ELECTRICAL DETAILS
- E-0.8 ELECTRICAL DETAILS
- E-0.9 ELECTRICAL SCHEDULES AND DETAILS
- E-0.10 ELECTRICAL DETAILS
- E-0.11 ELECTRICAL DETAILS

- ED1.1 ELECTRICAL DEMOLITION FIRST FLOOR PLAN - POWER
- ED1.2 ELECTRICAL DEMOLITION FIRST FLOOR PLAN - MECHANICAL POWER
- ED1.3 ELECTRICAL DEMOLITION FIRST FLOOR PLAN - LIGHTING
- ED1.4 ELECTRICAL DEMOLITION FIRST FLOOR PLAN - SYSTEMS

- EP1.1 ELECTRICAL FIRST FLOOR PLAN - POWER
- EP1.2 ELECTRICAL SECOND FLOOR PLAN - POWER
- EP1.3 ELECTRICAL FIRST FLOOR PLAN - MECHANICAL EQUIPMENT
POWER
- EP1.4 ELECTRICAL FIRST FLOOR PLAN - CABLE TRAY

- EL1.1 ELECTRICAL FIRST AND SECOND FLOOR PLANS - LIGHTING

FIRE ALARM:

- F0.1 FIRE ALARM LEGEND, MATRIX AND FUNCTIONAL FIRE ALARM RISER
- F0.2 FIRE ALARM DETAILS
- F1.1 FIRE ALARM FIRST AND SECOND FLOOR PLAN

FIRE PROTECTION:

- FP1.1 FIRE PROTECTION FIRST FLOOR PLAN
- FP1.2 FIRE PROTECTION DETAILS

ARTICLE 8, MATERIALS, EQUIPMENT AND EMPLOYEES

Delete paragraph “d” and replace with the following.

“Each contractor shall obtain written approval from the designer for use of products, materials, equipment, and assemblies claimed as equal to those specified. Substitution

requests will only be considered up to 10 days prior to the bid date unless the product is no longer manufactured, to comply with governing authorities or as directed by the owner. Reference 01 25 00, Product Substitutions, for additional substitution requirements.

ARTICLE 19, CHANGES IN THE WORK

Add as paragraph “k.”

“Change orders will be completed by utilizing Interscope Plus, the online system from the Office of State Construction. The Contractor shall promptly login and take appropriate action after receiving email notification from the Interscope system that a change order has been posted.”

ARTICLE 23, TIME OF COMPLETION, DELAYS, EXTENSION OF TIME

Add to paragraph “b.”

“The contractor shall commence work to be performed under the base bid of this agreement on a date to be specified in a written order from the designer and shall fully complete all work hereunder within **350** consecutive calendar days from the said date. For each day in excess of the above number of days, the contractors shall each pay to the Owner the sum of **\$200** as liquidated damages reasonably estimated in advance to cover the losses to be incurred by the Owner by reason of failure of said contractors to complete the work within the time specified, such time being of the essence of this contract and a material consideration thereof. ”

ARTICLE 31, REQUEST FOR PAYMENT

Add the following:

- c. “The Contractor shall submit a schedule of values within 14 days from date of Construction Contract. The Schedule of Values shall have separate line items for each specification section. Additionally, each section shall have individual lines for material and labor.”
- f. “Contractor shall submit to the Designer a request for payment on AIA Document G702 unless otherwise approved by the Designer.”

ARTICLE 34, MINIMUM INSURANCE REQUIRED

- c. Revise to read as follows: **Property Insurance (Builder’s Risk/Installation Floater):**

Add the following sentence: “Property insurance specified in Subparagraph c shall include the Owner, the Architect and his consultants, the Contractor and his subcontractors as additional insured parties in the policy.”

In the second sentence after the words “against the perils of fire,” add the following: “hurricane, flood and wind.”

ARTICLE 40, UTILITIES, STRUCTURES, SIGNS

Add to paragraph “a.”

“The General Contractor is designated as the project expediter and shall provide all utilities, structures and signs required by the construction of this project in accordance with the provisions of this Article. “

Add to paragraph “f.”

“The General Contractor shall furnish suitable temporary lighting where required during construction for all contractors. The General Contractor is only permitted to use permanent lighting during finishing and punchout. Fixtures shall be protected at all times, and shall be wiped clean of debris, dust, and fingerprints prior to final inspection.”

Add to paragraph “h.5.”

“When the permanent lighting system is used during the finishing stages of construction, lamps shall be replaced by the electrical contractor and shall be new at the time of final inspections. Prior to the finishing state, the contractor shall mark all lamps in a fashion suitable to the owner to identify lamps used during the finishing stages of construction requiring replacement just prior to final inspection. The electrical contractor shall have all lamps in proper working condition at the time of final project acceptance.”

Add the following to item “j.”

"General Contractor shall not be required to provide his own office facility including telephone, computer and color printer required at location on site approved by the Architect and Owner.

Portable toilets must be provided on site. The Owner's toilet facilities shall not be used at any time during the project."

ARTICLE 42, GUARANTEE

Add to paragraph “e.”

“All warranty periods to be begin at “Final Acceptance” date rather than at the ‘Beneficial Occupancy’ date.”

ARTICLE 45, TAXES

Add the following:

- e. “Contractors shall submit monthly with their request for payment, a signed statement containing the amount of sales and use tax paid by the Contractor for that particular billing period.”

END SUPPLEMENTARY GENERAL CONDITIONS

GUIDELINES FOR RECRUITMENT AND SELECTION OF MINORITY BUSINESSES FOR PARTICIPATION IN STATE CONSTRUCTION CONTRACTS

In accordance with G.S. 143-128.2 (effective January 1, 2002) these guidelines establish goals for minority participation in single-prime bidding, separate-prime bidding, construction manager at risk, and alternative contracting methods, on State construction projects in the amount of \$300,000 or more. The legislation provides that the State shall have a verifiable ten percent (10%) goal for participation by minority businesses in the total value of work for each project for which a contract or contracts are awarded. These requirements are published to accomplish that end.

SECTION A: INTENT

It is the intent of these guidelines that the State of North Carolina, as awarding authority for construction projects, and the contractors and subcontractors performing the construction contracts awarded shall cooperate and in good faith do all things legal, proper and reasonable to achieve the statutory goal of ten percent (10%) for participation by minority businesses in each construction project as mandated by GS 143-128.2. Nothing in these guidelines shall be construed to require contractors or awarding authorities to award contracts or subcontracts to or to make purchases of materials or equipment from minority-business contractors or minority-business subcontractors who do not submit the lowest responsible, responsive bid or bids.

SECTION B: DEFINITIONS

1. Minority - a person who is a citizen or lawful permanent resident of the United States and who is:
 - a. Black, that is, a person having origins in any of the black racial groups in Africa;
 - b. Hispanic, that is, a person of Spanish or Portuguese culture with origins in Mexico, South or Central America, or the Caribbean Islands, regardless of race;
 - c. Asian American, that is, a person having origins in any of the original peoples of the Far East, Southeast Asia and Asia, the Indian subcontinent, the Pacific Islands;
 - d. American Indian, that is, a person having origins in any of the original peoples of North America; or
 - e. Female
2. Minority Business - means a business:
 - a. In which at least fifty-one percent (51%) is owned by one or more minority persons, or in the case of a corporation, in which at least fifty-one percent (51%) of the stock is owned by one or more minority persons or socially and economically disadvantaged individuals; and
 - b. Of which the management and daily business operations are controlled by one or more of the minority persons or socially and economically disadvantaged individuals who own it.
3. Socially and economically disadvantaged individual - means the same as defined in 15 U.S.C. 637. "Socially disadvantaged individuals are those who have been subjected to racial or ethnic prejudice or cultural bias because of their identity as a member of a group without regard to their individual qualities". "Economically disadvantaged individuals are those socially disadvantaged individuals whose ability to compete in the free enterprise system has been impaired due to diminished capital and credit opportunities as compared to others in the same business area who are not socially disadvantaged".
4. Public Entity - means State and all public subdivisions and local governmental units.
5. Owner - The State of North Carolina, through the Agency/Institution named in the contract.
6. Designer – Any person, firm, partnership, or corporation, which has contracted with the State of North Carolina to perform architectural or engineering, work.
7. Bidder - Any person, firm, partnership, corporation, association, or joint venture seeking to be awarded a public contract or subcontract.

8. Contract - A mutually binding legal relationship or any modification thereof obligating the seller to furnish equipment, materials or services, including construction, and obligating the buyer to pay for them.
9. Contractor - Any person, firm, partnership, corporation, association, or joint venture which has contracted with the State of North Carolina to perform construction work or repair.
10. Subcontractor - A firm under contract with the prime contractor or construction manager at risk for supplying materials or labor and materials and/or installation. The subcontractor may or may not provide materials in his subcontract.

SECTION C: RESPONSIBILITIES

1. Office for Historically Underutilized Businesses, Department of Administration (hereinafter referred to as HUB Office).

The HUB Office has established a program, which allows interested persons or businesses qualifying as a minority business under G.S. 143-128.2, to obtain certification in the State of North Carolina procurement system. The information provided by the minority businesses will be used by the HUB Office to:

- a. Identify those areas of work for which there are minority businesses, as requested.
- b. Make available to interested parties a list of prospective minority business contractors and subcontractors.
- c. Assist in the determination of technical assistance needed by minority business contractors.

In addition to being responsible for the certification/verification of minority businesses that want to participate in the State construction program, the HUB Office will:

- (1) Maintain a current list of minority businesses. The list shall include the areas of work in which each minority business is interested.
- (2) Inform minority businesses on how to identify and obtain contracting and subcontracting opportunities through the State Construction Office and other public entities.
- (3) Inform minority businesses of the contracting and subcontracting process for public construction building projects.
- (4) Work with the North Carolina trade and professional organizations to improve the ability of minority businesses to compete in the State construction projects.
- (5) The HUB Office also oversees the minority business program by:
 - a. Monitoring compliance with the program requirements.
 - b. Assisting in the implementation of training and technical assistance programs.
 - c. Identifying and implementing outreach efforts to increase the utilization of minority businesses.
 - d. Reporting the results of minority business utilization to the Secretary of the Department of Administration, the Governor, and the General Assembly.

2. State Construction Office

The State Construction Office will be responsible for the following:

- a. Furnish to the HUB Office a minimum of twenty-one days prior to the bid opening the following:
 - (1) Project description and location;
 - (2) Locations where bidding documents may be reviewed;
 - (3) Name of a representative of the owner who can be contacted during the advertising period to advise who the prospective bidders are;
 - (4) Date, time and location of the bid opening.
 - (5) Date, time and location of prebid conference, if scheduled.
- b. Attending scheduled prebid conference, if necessary, to clarify requirements of the general statutes regarding minority-business participation, including the bidders' responsibilities.

- c. Reviewing the apparent low bidders' statutory compliance with the requirements listed in the proposal, that must be complied with, if the bid is to be considered as responsive, prior to award of contracts. The State reserves the right to reject any or all bids and to waive informalities.
- d. Reviewing of minority business requirements at Preconstruction conference.
- e. Monitoring of contractors' compliance with minority business requirements in the contract documents during construction.
- f. Provide statistical data and required reports to the HUB Office.
- g. Resolve any protest and disputes arising after implementation of the plan, in conjunction with the HUB Office.

3. Owner

Before awarding a contract, owner shall do the following:

- a. Develop and implement a minority business participation outreach plan to identify minority businesses that can perform public building projects and to implement outreach efforts to encourage minority business participation in these projects to include education, recruitment, and interaction between minority businesses and non-minority businesses.
- b. Attend the scheduled prebid conference.
- c. At least 10 days prior to the scheduled day of bid opening, notify minority businesses that have requested notices from the public entity for public construction or repair work and minority businesses that otherwise indicated to the Office for Historically Underutilized Businesses an interest in the type of work being bid or the potential contracting opportunities listed in the proposal. The notification shall include the following:
 - 1. A description of the work for which the bid is being solicited.
 - 2. The date, time, and location where bids are to be submitted.
 - 3. The name of the individual within the owner's organization who will be available to answer questions about the project.
 - 4. Where bid documents may be reviewed.
 - 5. Any special requirements that may exist.
- d. Utilize other media, as appropriate, likely to inform potential minority businesses of the bid being sought.
- e. Maintain documentation of any contacts, correspondence, or conversation with minority business firms made in an attempt to meet the goals.
- f. Review, jointly with the designer, all requirements of G.S. 143-128.2(c) and G.S. 143-128.2(f) – (i.e. bidders' proposals for identification of the minority businesses that will be utilized with corresponding total dollar value of the bid and affidavit listing good faith efforts, or affidavit of self-performance of work, if the contractor will perform work under contract by its own workforce) - prior to recommendation of award to the State Construction Office.
- g. Evaluate documentation to determine good faith effort has been achieved for minority business utilization prior to recommendation of award to State Construction Office.
- h. Review prime contractors' pay applications for compliance with minority business utilization commitments prior to payment.
- i. Make documentation showing evidence of implementation of Owner's responsibilities available for review by State Construction Office and HUB Office, upon request

4. Designer

Under the single-prime bidding, separate prime bidding, construction manager at risk, or alternative contracting method, the designer will:

- a. Attend the scheduled prebid conference to explain minority business requirements to the prospective bidders.
- b. Assist the owner to identify and notify prospective minority business prime and subcontractors of potential contracting opportunities.
- c. Maintain documentation of any contacts, correspondence, or conversation with minority business firms made in an attempt to meet the goals.
- d. Review jointly with the owner, all requirements of G.S. 143-128.2(c) and G.S.143-128.2(f) – (i.e. bidders' proposals for identification of the minority businesses that will be utilized with

corresponding total dollar value of the bid and affidavit listing Good Faith Efforts, or affidavit of self-performance of work, if the contractor will perform work under contract by its own workforce) - prior to recommendation of award.

- e. During construction phase of the project, review “MBE Documentation for Contract Payment” – (Appendix E) for compliance with minority business utilization commitments. Submit Appendix E form with monthly pay applications to the owner and forward copies to the State Construction Office.
- f. Make documentation showing evidence of implementation of Designer’s responsibilities available for review by State Construction Office and HUB Office, upon request.

5. Prime Contractor(s), CM at Risk, and Its First-Tier Subcontractors

Under the single-prime bidding, the separate-prime bidding, construction manager at risk and alternative contracting methods, contractor(s) will:

- a. Attend the scheduled prebid conference.
- b. Identify or determine those work areas of a subcontract where minority businesses may have an interest in performing subcontract work.
- c. At least ten (10) days prior to the scheduled day of bid opening, notify minority businesses of potential subcontracting opportunities listed in the proposal. The notification will include the following:
 - (1) A description of the work for which the subbid is being solicited.
 - (2) The date, time and location where subbids are to be submitted.
 - (3) The name of the individual within the company who will be available to answer questions about the project.
 - (4) Where bid documents may be reviewed.
 - (5) Any special requirements that may exist, such as insurance, licenses, bonds and financial arrangements.

If there are more than three (3) minority businesses in the general locality of the project who offer similar contracting or subcontracting services in the specific trade, the contractor(s) shall notify three (3), but may contact more, if the contractor(s) so desires.

- d. During the bidding process, comply with the contractor(s) requirements listed in the proposal for minority participation.
- e. Identify on the bid, the minority businesses that will be utilized on the project with corresponding total dollar value of the bid and affidavit listing good faith efforts as required by G.S. 143-128.2(c) and G.S. 143-128.2(f).
- f. Make documentation showing evidence of implementation of PM, CM-at-Risk and First-Tier Subcontractor responsibilities available for review by State Construction Office and HUB Office, upon request.
- g. Upon being named the apparent low bidder, the Bidder shall provide one of the following: (1) an affidavit (Affidavit C) that includes a description of the portion of work to be executed by minority businesses, expressed as a percentage of the total contract price, which is equal to or more than the applicable goal; (2) if the percentage is not equal to the applicable goal, then documentation of all good faith efforts taken to meet the goal. Failure to comply with these requirements is grounds for rejection of the bid and award to the next lowest responsible and responsive bidder.
- h. The contractor(s) shall identify the name(s) of minority business subcontractor(s) and corresponding dollar amount of work on the schedule of values. The schedule of values shall be provided as required in Article 31 of the General Conditions of the Contract to facilitate payments to the subcontractors.
- i. The contractor(s) shall submit with each monthly pay request(s) and final payment(s), “MBE Documentation for Contract Payment” – (Appendix E), for designer’s review.
- j. During the construction of a project, at any time, if it becomes necessary to replace a minority business subcontractor, immediately advise the owner, State Construction Office, and the Director of the HUB Office in writing, of the circumstances involved. The prime contractor shall make a good faith effort to replace a minority business subcontractor with another minority business subcontractor.

- k. If during the construction of a project additional subcontracting opportunities become available, make a good faith effort to solicit subbids from minority businesses.
- l. It is the intent of these requirements apply to all contractors performing as prime contractor and first tier subcontractor under construction manager at risk on state projects.

6. Minority Business Responsibilities

While minority businesses are not required to become certified in order to participate in the State construction projects, it is recommended that they become certified and should take advantage of the appropriate technical assistance that is made available. In addition, minority businesses who are contacted by owners or bidders must respond promptly whether or not they wish to submit a bid.

SECTION 4: DISPUTE PROCEDURES

It is the policy of this state that disputes that involves a person's rights, duties or privileges, should be settled through informal procedures. To that end, minority business disputes arising under these guidelines should be resolved as governed under G.S. 143-128(g).

SECTION 5: These guidelines shall apply upon promulgation on state construction projects. Copies of these guidelines may be obtained from the Department of Administration, State Construction Office, (physical address) 301 North Wilmington Street, Suite 450, NC Education Building, Raleigh, North Carolina, 27601-2827, (mail address) 1307 Mail Service Center, Raleigh, North Carolina, 27699-1307, phone (919) 807-4100, Website: www.nc-sco.com

SECTION 6: In addition to these guidelines, there will be issued with each construction bid package provisions for contractual compliance providing minority business participation in the state construction program.

MINORITY BUSINESS CONTRACT PROVISIONS (CONSTRUCTION)

APPLICATION:

The **Guidelines for Recruitment and Selection of Minority Businesses for Participation in State Construction Contracts** are hereby made a part of these contract documents. These guidelines shall apply to all contractors regardless of ownership. Copies of these guidelines may be obtained from the Department of Administration, State Construction Office, (physical address) 301 North Wilmington Street, Suite 450, NC Education Building, Raleigh, North Carolina, 27601-2827, (mail address) 1307 Mail Service Center, Raleigh, North Carolina, 27699-1307, phone (919) 807-4100, Website: <http://www.nc-sco.com>

MINORITY BUSINESS SUBCONTRACT GOALS:

The goals for participation by minority firms as subcontractors on this project have been set at 10%.

The bidder must identify on its bid, the minority businesses that will be utilized on the project with corresponding total dollar value of the bid and affidavit (Affidavit A) listing good faith efforts **or** affidavit (Affidavit B) of self-performance of work, if the bidder will perform work under contract by its own workforce, as required by G.S. 143-128.2(c) and G.S. 143-128.2(f).

The lowest responsible, responsive bidder must provide Affidavit C, that includes a description of the portion of work to be executed by minority businesses, expressed as a percentage of the total contract price, which is equal to or more than the applicable goal.

OR

Provide Affidavit D, that includes a description of the portion of work to be executed by minority businesses, expressed as a percentage of the total contract price, **with documentation of Good Faith Effort, if the percentage is not equal to the applicable goal.**

OR

Provide Affidavit B, which includes sufficient information for the State to determine that the bidder does not customarily subcontract work on this type project.

The above information must be provided as required. Failure to submit these documents is grounds for rejection of the bid.

MINIMUM COMPLIANCE REQUIREMENTS:

All written statements, affidavits or intentions made by the Bidder shall become a part of the agreement between the Contractor and the State for performance of this contract. Failure to comply with any of these statements, affidavits or intentions, or with the minority business Guidelines shall constitute a breach of the contract. A finding by the State that any information submitted either prior to award of the contract or during the performance of the contract is inaccurate, false or incomplete, shall also constitute a breach of the contract. Any such breach may result in termination of the contract in accordance with the termination provisions contained in the contract. It shall be solely at the option of the State whether to terminate the contract for breach.

In determining whether a contractor has made Good Faith Efforts, the State will evaluate all efforts made by the Contractor and will determine compliance in regard to quantity, intensity, and results of these efforts. Good Faith Efforts include:

- (1) Contacting minority businesses that reasonably could have been expected to submit a quote and that were known to the contractor or available on State or local government maintained lists at least 10 days before the bid or proposal date and notifying them of the nature and scope of the work to be performed.
- (2) Making the construction plans, specifications and requirements available for review by prospective minority businesses, or providing these documents to them at least 10 days before the bid or proposals are due.
- (3) Breaking down or combining elements of work into economically feasible units to facilitate minority participation.
- (4) Working with minority trade, community, or contractor organizations identified by the Office for Historically Underutilized Businesses and included in the bid documents that provide assistance in recruitment of minority businesses.
- (5) Attending any prebid meetings scheduled by the public owner.
- (6) Providing assistance in getting required bonding or insurance or providing alternatives to bonding or insurance for subcontractors.
- (7) Negotiating in good faith with interested minority businesses and not rejecting them as unqualified without sound reasons based on their capabilities. Any rejection of a minority business based on lack of qualification should have the reasons documented in writing.
- (8) Providing assistance to an otherwise qualified minority business in need of equipment, loan capital, lines of credit, or joint pay agreements to secure loans, supplies, or letters of credit, including waiving credit that is ordinarily required. Assisting minority businesses in obtaining the same unit pricing with the bidder's suppliers in order to help minority businesses in establishing credit.
- (9) Negotiating joint venture and partnership arrangements with minority businesses in order to increase opportunities for minority business participation on a public construction or repair project when possible.
- (10) Providing quick pay agreements and policies to enable minority contractors and suppliers to meet cash-flow demands.

APPENDIX E

MBE DOCUMENTATION FOR CONTRACT PAYMENTS

Prime Contractor/Architect: _____

Address & Phone: _____

Project Name: _____

Pay Application #: _____ Period: _____

The following is a list of payments made to Minority Business Enterprises on this project for the above-mentioned period.

MBE FIRM NAME	* INDICATE TYPE OF MBE	AMOUNT PAID THIS MONTH	TOTAL PAYMENTS TO DATE	TOTAL AMOUNT COMMITTED

*Minority categories: Black, African American (B), Hispanic (H), Asian American (A), American Indian (I), Female (F), Social and Economically Disadvantage (D)

Date: _____ Approved/Certified By: _____

Name

Title

Signature

SUBMIT WITH EACH PAY REQUEST & FINAL PAYMENT

STATE OF NORTH CAROLINA
 COUNTY SALES AND USE TAX REPORT
 SUMMARY TOTALS AND CERTIFICATION

CONTRACTOR: _____

Page 1 of _____

PROJECT: _____

FOR PERIOD: _____

	TOTAL FOR COUNTY OF:	TOTAL FOR COUNTY OF:	TOTAL FOR COUNTY OF:	TOTAL FOR COUNTY OF:	TOTAL FOR COUNTY OF:	TOTAL ALL COUNTIES
CONTRACTOR						
SUBCONTRACTOR(S)*						
COUNTY TOTAL						

* Attach subcontractor(s) report(s)
 ** Must balance with Detail Sheet(s)

I certify that the above figures do not include any tax paid on supplies, tools and equipment which were used to perform this contract and only includes those building materials, supplies, fixtures and equipment which actually became a part of or annexed to the building or structure. I certify that, to the best of my knowledge, the information provided here is true, correct, and complete.

Sworn to and subscribed before me,

This the _____ day of _____, 20____

 Signed

 Notary Public

My Commission Expires: _____

 Print or Type Name of Above

Seal

NOTE:
 This certified statement may be subject to audit.

STATE OF NORTH CAROLINA
SALES AND USE TAX REPORT DETAIL

CONTRACTOR: _____

SUBCONTRACTOR _____ FOR PERIOD: _____

PROJECT: _____

PURCHASE DATE	VENDOR NAME	INVOICE NUMBER	TYPE OF PROPERTY	INVOICE TOTAL	COUNTY TAX PAID	COUNTY OF SALE *
				\$	\$	
				TOTAL:	\$	

* If this is an out-of-state vendor, the County of Sale should be the county to which the merchandise was shipped.

PROJECT:

APPLICATION NO:

Distribution to:

OWNER
 ARCHITECT
 CONTRACTOR

PERIOD TO:

VIA ARCHITECT:

FROM CONTRACTOR:

PROJECT NO:

CONTRACT DATE:

CONTRACT FOR:

CONTRACTOR'S APPLICATION FOR PAYMENT

Application is made for payment, as shown below, in connection with the Contract. Continuation Sheet, AIA Document G703, is attached.

1. ORIGINAL CONTRACT SUM \$ _____
2. Net change by Change Orders \$ _____
3. CONTRACT SUM TO DATE (Line 1 ± 2) \$ _____
4. TOTAL COMPLETED & STORED TO DATE (Column G on G703) \$ _____
5. RETAINAGE:
 - a. _____ % of Completed Work (Column D + E - F on G703) \$ _____
 - b. _____ % of Stored Material (Column F on G703) \$ _____
 Total Retainage (Lines 5a + 5b or Total in Column I of G703) \$ _____
6. TOTAL EARNED LESS RETAINAGE (Line 4 Less Line 5 Total) \$ _____
7. LESS PREVIOUS CERTIFICATES FOR PAYMENT (Line 6 from prior Certificate) \$ _____
8. CURRENT PAYMENT DUE \$ _____
9. BALANCE TO FINISH, INCLUDING RETAINAGE (Line 3 less Line 6) \$ _____

CHANGE ORDER SUMMARY	ADDITIONS	DEDUCTIONS
Total changes approved in previous months by Owner		
Total approved this Month		
TOTALS		
NET CHANGES by Change Order		

The undersigned Contractor certifies that to the best of the Contractor's knowledge, information and belief the Work covered by this Application for Payment has been completed in accordance with the Contract Documents, that all amounts have been paid by the Contractor for Work for which previous Certificates for Payment were issued and payments received from the Owner, and that current payment shown herein is now due.

CONTRACTOR:

By: _____ Date _____
 State of: North Carolina County of: New Hanover
 Subscribed and sworn before this _____ day of _____ 2009
 Notary Public:
 My Commission expires:

ARCHITECT'S CERTIFICATE FOR PAYMENT

In accordance with the Contract Documents, based on on-site observations and the data comprising the application, the Architect certifies to the Owner that to the best of the Architect's knowledge, information and belief the Work has progressed as indicated, the quality of the Work is in accordance with the Contract Documents, and the Contractor is entitled to payment of the AMOUNT CERTIFIED.

AMOUNT CERTIFIED \$ _____
 (Attach explanation if amount certified differs from the amount applied. Initial a Application and on the Continuation Sheet that are changed to conform with the amount certified.)

ARCHITECT: _____ Date: _____
 By: _____

This Certificate is not negotiable. The AMOUNT CERTIFIED is payable only to the Contractor named herein. Issuance, payment and acceptance of payment are without prejudice to any rights of the Owner or Contractor under this Contract.

ACCEPTED BY OWNER:

The review and acceptance of this estimate does not attest to the correctness of the quantities shown or that the work has been performed in accordance with the contract documents.

BY: _____
 TITLE: _____
 DATE: _____

CONTRACT TIME

ORIGINAL (DAYS) _____ STARTING DATE _____
 REVISED ON SCHEDULE - YES ___ NO ___ PROJECTED COMPLETION _____
 REMAINING _____

CONTINUATION SHEET G-703

APPLICATION NO:
APPLICATION DATE:
PERIOD TO:
ARCHITECT'S PROJECT NO:

Contractor's signed certification is attached.
In tabulations below, amounts are stated to the nearest dollar.
Use Column I on Contracts where variable retainage for line items may apply.

A ITEM NO.	B DESCRIPTION OF WORK	C SCHEDULED VALUE	D WORK COMPLETED		E THIS PERIOD	F MATERIALS PRESENTLY STORED (NOT IN D OR E)	G TOTAL COMPLETED AND STORED TO DATE (D+E+F)	% (G ÷ C)	H BALANCE TO FINISH (C - G)	I RETAINAGE (IF VARIABLE RATE)
			FROM PREVIOUS APPLICATION (D + E)	THIS PERIOD						
GRAND TOTALS										

January 7, 2011

Owner

Designer

Contractor SCO ID # _____

Surety

Other

CONSENT OF SURETY

COMPANY TO FINAL

PAYMENT

For Use with State of North Carolina Projects

PROJECT Name & Location: _____

TO: (OWNER)

CONTRACT FOR:

CONTRACT DATE:

CONTRACTOR:

In accordance with the provisions of the contract between the owner and the contractor as indicated above, the (here insert name and address of surety company)

SURETY COMPANY

on bond of (here insert name and address of contractor)

CONTRACTOR

hereby approves of the final payment to the contractor, and agrees that final payment to the contractor shall not relieve the surety company of any of its obligations to (here insert name and address of owner)

OWNER

as set forth in said surety company's bond.

IN WITNESS WHEREOF,
the surety company has hereunto set its hand this day of 20

Surety Company

Signature of Authorized Representative

Attest:

Title

(Visible Seal):

SECTION 316

Owner

Designer

Contractor Code _____ Item _____

Surety

Other

CONTRACTOR'S

AFFIDAVIT OF

RELEASE OF LIENS

For Use with State of North Carolina Projects

TO: (OWNER)

CONTRACT FOR:

CONTRACT DATE:

SCO PROJECT ID:

PROJECT INFORMATION:
(Name & Location)

State of:

County of:

The undersigned, pursuant to Article 36 of the General Conditions of the Contract, hereby certifies that to the best of his knowledge, information and belief, the Releases or Waivers of Lien attached hereto include the contractor, all subcontractors, all suppliers of materials and equipment, and all performers of work, labor or services who have or may have liens against any property of the owner arising in any manner out of the performance of the contract referenced above.

SUPPORTING DOCUMENTS

ATTACHED HERETO:

CONTRACTOR:

Address:

By

Subscribed and sworn to before me
this day of 20

Signature Notary Public:

Printed Name of Notary Public:

My Commission Expires:

**CONTRACTOR'S
AFFIDAVIT OF PAYMENT
OF DEBTS AND CLAIMS**

Owner
Designer
Contractor Code _____ Item _____
Surety
Other

For Use with State of North Carolina Projects

TO (OWNER)

CONTRACT FOR:

CONTRACT DATE:

PROJECT INFORMATION:

Name & Location:

State of: _____

County of:

The undersigned, pursuant to Article 36 of the General Conditions of the Contract, hereby certifies that, he has paid in full or has otherwise satisfied all obligations for all materials and equipment furnished, for all work, labor and services performed, and for all known indebtedness and claims against the contractor for damages arising in any manner in connection with the performance of the contract referenced above for which the owner or his property might in any way be held responsible.

SUPPORTING DOCUMENTS ATTACHED HERETO:

1. Consent of Surety to Final Payment. Whenever surety is involved, Consent of Surety is required. Indicate attachment: (yes) (no).
The following supporting documents should be attached hereto if required by the owner:
 - a. Contractor's Release or Waiver of Liens, conditional upon receipt of final payment.
 - b. Separate Releases or Waivers of Liens from subcontractors and material and equipment suppliers to the extent required by the owner, accompanied by a list thereof.
 - c. Contractor's Affidavit of Release of Liens.

CONTRACTOR:

Address:

By:
Subscribed and sworn to before me this ___ day of _____ 20__

Signature of Notary Public:

Printed Name of Notary Public:

My Commission Expires:



ECS SOUTHEAST, LLC

NC Engineering License No. F-1519

Geotechnical • Construction Materials • Environmental • Facilities

May 23, 2024

Ms. Carol Lurz
Coastal Carolina Community College
444 Western Boulevard
Jacksonville, North Carolina 28546

ECS Project No. 22:33881-A1

Reference: Geotechnical Engineering Report - Addendum
CCCC – LRC 1st Floor Renovation
Jacksonville, Onslow County, North Carolina

Dear Ms. Lurz:

ECS Southeast, LLC (ECS) understands the proposed canopies adjacent to the existing structure are anticipated to be supported on a foundation consisting of 8-inch tip, round timber piles. ECS was requested to provide additional pile capacities for the site.

Deep Foundations

The proposed construction can be supported on a deep foundation system consisting of driven timber piles. The following tables shows the allowable pile capacities for 8-inch tip, round timber piles. **The embedment depths listed are in reference to the existing grade at the time the soundings were performed. If grades are changed prior to driving piles the embedment depths should be adjusted to account for any cut or fill on the site.**

Table 1: 8-Inch Tip Round Timber Piles

Embedment Depth (Feet)	Axial Capacity (kips)	Uplift (kips)	Lateral (kips)
30 feet	30	4	3.5

In our opinion, piles installed to depths shallower than recommended depths, would not provide long-term stability of the proposed structure. Pile capacity analyses were performed estimating a free head condition and the provided compression and tension capacities are based on a factor of safety of 2.0 and 3.0, respectively.

We recommend that the pile driving hammer used to install each timber pile have a minimum rated energy blow of 5,000 foot-pounds. Driving criteria and bearing elevations should be established prior to driving piles. Based on the subsurface conditions, we recommend that the piles installed use a pre-auger depth of approximately 8 feet below existing grades to limit vibration from pile driving. Driving criteria and bearing elevations should be established prior to driving piles.

ECS would be pleased to develop driving criteria for the project once the method of installation and the contractor has been selected.

6714 NETHERLANDS DRIVE, WILMINGTON, NC 28405 • T: 910-686-9114 • F: 910-686-9666

ECS Florida, LLC • ECS Mid-Atlantic, LLC • ECS Midwest, LLC • ECS Pacific, Inc. • ECS Southeast, LLC • ECS Southwest, LLP
ECS New York Engineering, PLLC - An Associate of ECS Group of Companies • www.ecslimited.com

"ONE FIRM. ONE MISSION."

Closing

It has been our pleasure to be of service to you during the design phase of this project. We would appreciate the opportunity to remain involved during the continuation of the design phase, and we would like to provide our services during construction phase operations as well to verify the assumptions of subsurface conditions made for this report. Should you have any questions concerning the information contained in this report, or if we can be of further assistance to you, please contact us.

Respectfully submitted,
ECS Southeast, LLC
NC Firm No. F-1519

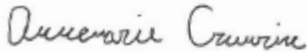

Annemarie Crumrine, PE
Geotechnical Department Manager
ACrumrine@ecslimited.com

DocuSigned by:



2D745DA276044AF...

Winslow Goins, PE

Principal Engineer

DocuSigned by:

WGoins@ecslimited.com

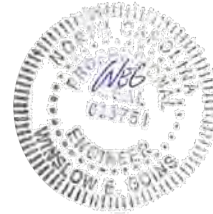

5/23/2024



ECS Southeast, LLP

Geotechnical Engineering Report

CCCC – LRC 1st Floor Renovation

444 Western Blvd
Jacksonville, Onslow County, North Carolina

ECS Project No. 22:33881

November 2, 2023





November 2, 2023

Ms. Carol Lurz
Coastal Carolina Community College
444 Western Blvd
Jacksonville, North Carolina 28546

ECS Project No. 22:33881

Reference: Geotechnical Engineering Report
CCCC – LRC 1st Floor Renovation
444 Western Blvd
Jacksonville, Onslow County, North Carolina

Dear Ms. Lurz:

ECS Southeast, LLP (ECS) has completed the subsurface exploration and geotechnical engineering analyses for the above-referenced project. Our services were performed in general accordance with our agreed to scope of work. This report presents our understanding of the geotechnical aspects of the project along with the results of the field exploration conducted and our design and construction recommendations.

It has been our pleasure to be of service during the design phase of this project. We would appreciate the opportunity to remain involved during the continuation of the design phase, and we would like to provide our services during construction phase operations as well to verify subsurface conditions assumed for this report. Should you have any questions concerning the information contained in this report, or if we can be of further assistance to you, please contact us.

Respectfully submitted,

ECS Southeast, LLP

Freddie Wescott
Senior Project Manager
FWescott@ecslimited.com

Winslow Goins, PE
Principal Engineer
WGoins@ecslimited.com



TABLE OF CONTENTS

EXECUTIVE SUMMARY	1
1.0 INTRODUCTION	2
2.0 PROJECT INFORMATION	3
2.1 Project Location/Current Site Use/Past Site Use	3
2.2 Proposed Construction.....	3
3.0 FIELD EXPLORATION	4
3.1 Subsurface characterization.....	4
3.2 Groundwater Observations.....	4
4.0 DESIGN RECOMMENDATIONS	5
4.1 Foundations.....	5
4.2 Slabs On Grade	6
5.0 SITE CONSTRUCTION RECOMMENDATIONS	7
5.1 Subgrade Preparation	7
5.1.1 Stripping and Grubbing.....	7
5.1.2 Proofrolling	7
5.1.3 Site Temporary Dewatering.....	7
5.2 Earthwork Operations	8
5.2.1 Structural Fill.....	8
5.3 Foundation and Slab Observations	8
5.4 Utility Installations	9
6.0 CLOSING.....	10

APPENDICES

Appendix A – Drawings & Reports

- Site Location Diagram
- Exploration Location Diagram

Appendix B – Field Operations

- Reference Notes for CPT Testing
- Cone Penetration Test Sounding Logs (S-1 and S-2)

Appendix C – Supplemental Report Documents

- GBA Document

EXECUTIVE SUMMARY

The following summarizes the main findings of the exploration, particularly those that may have a cost impact on the planned development. Further, our principal foundation recommendations are summarized. Information gleaned from the executive summary should not be utilized in lieu of reading the entire geotechnical report.

- The geotechnical exploration performed for the site included two (2) electronic cone penetration test (CPT) soundings drilled to termination depths of approximately 35 feet.
- Provided the subgrades are prepared as recommended in this report and the column and wall loads do not exceed 50 kips and 3 kips per liner foot, respectively, the planned building may be supported by conventional shallow foundations consisting of column or strip footings bearing on compacted structural fill and natural soils using a net allowable soil bearing pressure of 2,000 psf.
- Groundwater was encountered in the soundings at depths ranging from approximately 5.3 feet to 6.4 feet below existing grade.
- Due to the near surface loose SANDS (SM, SP) encountered in the soundings and hand auger borings, in-place densification may be needed prior to construction of foundations or placement of fill.

Please note this Executive Summary is an important part of this report and should be considered a **“summary”** only. The subsequent sections of this report constitute our findings, conclusions, and recommendations in their entirety.

1.0 INTRODUCTION

The purpose of this study was to provide geotechnical information for the design of foundations and pavements for the proposed new LRC building addition located at 444 Western Blvd in Jacksonville, North Carolina. The recommendations developed for this report are based on project information supplied by Ms. Carol Lurz of Coastal Carolina Community College.

Our services were provided in accordance with our Proposal No. 22:27893.R1, dated October 6, 2023, as authorized by PO NO. P0037660 dated October 10, 2023.

This report contains the procedures and results of our subsurface exploration programs, review of existing site conditions, engineering analyses, and recommendations for the design and construction of the project.

The report includes the following items.

- A brief review and description of our field test procedures and the results of testing conducted;
- A review of surface topographical features and site conditions;
- A review of subsurface soil stratigraphy with pertinent available physical properties;
- Foundation recommendations;
 - Allowable bearing pressure;
 - Settlement estimates (total and differential);
- Site development recommendations;
- Suitability of soils for use as fill material;
- Discussion of groundwater impact;
- Compaction recommendations;
- Site vicinity map;
- Exploration location plan; and
- CPT sounding logs.

2.0 PROJECT INFORMATION

2.1 PROJECT LOCATION/CURRENT SITE USE/PAST SITE USE

The proposed site is located at 444 Western Blvd in Jacksonville, Onslow County, North Carolina. The site is bounded on all sides by the existing Coastal Carolina Community College infrastructure. Figure 2.1.1 below shows an image of where the site is located.

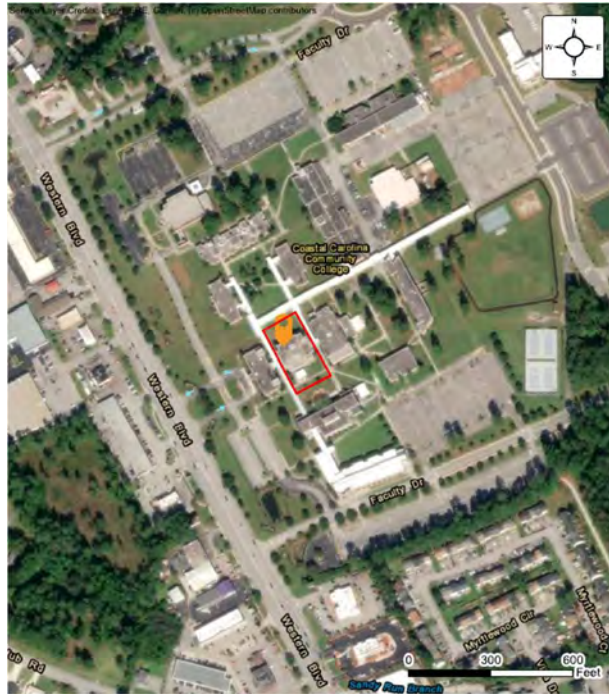

Figure 2.1.1 Site Location

The site currently consists of an open grassy area beside the existing LRC building. Based on our site visit and approximate elevations from Google Earth, the site is relatively level with typical elevations on site ranging from approximate 43 to 44 feet.

2.2 PROPOSED CONSTRUCTION

The following information explains our understanding of the planned development including proposed building and related infrastructure.

SUBJECT	DESIGN INFORMATION / ASSUMPTIONS
Usage	Institutional
Column Loads	Up to 50 kips
Wall Loads	Up to 3 klf

ECS understands the project consists of the construction of a new addition to the LRC building.

3.0 FIELD EXPLORATION

Our exploration procedures are explained in greater detail in Appendix B including the Reference Notes for Cone Penetration Soundings. Our scope of work included performing two (2) CPT soundings. Our approximate CPT sounding locations are shown on the Exploration Location Diagram in Appendix A.

3.1 SUBSURFACE CHARACTERIZATION

The subsurface conditions encountered were generally consistent with published geological mapping. The following sections provide generalized characterizations of the soil. Please refer to the CPT sounding logs in Appendix B.

The site is located in the Coastal Plain Physiographic Province of North Carolina. The Coastal Plain is composed of seven terraces, each representing a former level of the Atlantic Ocean. Soils in this area generally consist of sedimentary materials transported from other areas by the ocean or rivers. These deposits vary in thickness from a thin veneer along the western edge of the region to more than 10,000 feet near the coast. The sedimentary deposits of the Coastal Plain rest upon consolidated rocks similar to those underlying the Piedmont and Mountain Physiographic Provinces. In general, shallow unconfined groundwater movement within the overlying soils is largely controlled by topographic gradients. Recharge occurs primarily by infiltration along higher elevations and typically discharges into streams or other surface water bodies. The elevation of the shallow water table is transient and can vary greatly with seasonal fluctuations in precipitation.

Table 3.1.1 Subsurface Stratigraphy

Approximate Depth Range	Stratum	Description	Ranges of N*-Values(1) blows per foot (bpf)
0 to 0.17 (Surface cover)	N/A	Topsoil was encountered on-site with an observed thickness of approximately 2 inches. Deeper topsoil or organic laden soils are most likely present in wet, poorly drained areas and potentially unexplored areas of the site.	N/A
0.17 to 15	I	Very Loose to Medium Dense, Silty, Gravely, and Clean SAND (SM, SP), Very Soft to Stiff, Sandy and Clayey SILT (ML), Silty and Lean CLAY (CL).	1 to 24
15 to 35	II	Soft to Stiff, Clayey and Sandy SILT (ML), Silty and Lean CLAY (CL) and Very Loose to Dense, Silty, Gravely, and Clean SAND (SM, SP).	2 to 50

Notes: (1) Equivalent Corrected Standard Penetration Test Resistances

3.2 GROUNDWATER OBSERVATIONS

Water levels were measured in our CPT soundings and are shown in Appendix B. Groundwater depths measured at the time of drilling ranged from 3.8 to 7.7 feet below the ground surface. Variations in the long-term water table may occur as a result of changes in precipitation, evaporation, surface water runoff, construction activities, and other factors.

4.0 DESIGN RECOMMENDATIONS

4.1 FOUNDATIONS

Provided subgrades and structural fills are prepared as recommended in this report and in-place densification is performed by the design/build contractor, the proposed structures can be supported by shallow foundations including column footings and continuous wall footings. We recommend the foundation design use the following parameters:

Design Parameter	Column Footing	Wall Footing
Net Allowable Bearing Pressure ⁽¹⁾	2,000 psf	2,000 psf
Acceptable Bearing Soil Material	Stratum I or Approved structural fill	Stratum I or Approved structural Fill
Minimum Width	24 inches	12 inches
Minimum Footing Embedment Depth (below slab or finished grade) ⁽²⁾	12 inches	12 inches
Minimum Exterior Frost Depth (below final exterior grade)	6 inches	6 inches
Estimated Total Settlement ⁽³⁾	Less than 1- inch	Less than 1- inch
Estimated Differential Settlement ⁽⁴⁾	Less than ¾ inches between columns	Less than ¾ inches

Notes:

- (1) Net allowable bearing pressure is the applied pressure in excess of the surrounding overburden soils above the base of the foundation.
- (2) For bearing considerations and frost penetration requirements.
- (3) Based on assumed structural loads. If final loads are different, ECS must be contacted to update foundation recommendations and settlement calculations.
- (4) Based on maximum column/wall loads and variability in borings. Differential settlement can be re-evaluated once the foundation plans are more complete.

Potential Undercuts: Most of the soils at the foundation bearing elevation are anticipated to be suitable for support of the proposed structure. If soft or unsuitable soils are observed at the footing bearing elevations, the unsuitable soils should be undercut and removed. Any undercut should be backfilled with approved structural fill up to the original design bottom of footing elevation; the original footing shall be constructed on top of the approved structural fill.

4.2 SLABS ON GRADE

The on-site natural soils are generally considered suitable for support of the lowest floor slabs. Based on the assumption that the finished floor elevation is around the current site elevations, it appears that the slabs for the structure will likely bear on the near surface Stratum I soils SAND (SM, SP) or approved structural fill. The following graphic depicts our soil-supported slab recommendations:

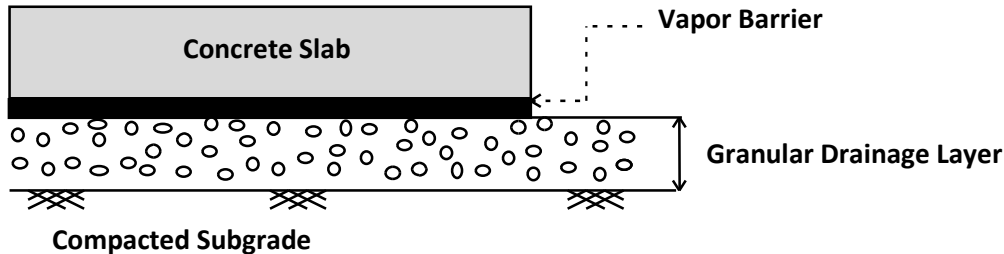

Figure 4.2.1

1. Drainage Layer Thickness: 6 inches
2. Drainage Layer Material: GRAVEL (GP, GW) or SAND containing <5% passing the #200 sieve (SP, SW)
3. Subgrade compacted to 98% maximum dry density per ASTM D698

Subgrade Modulus: Provided the structural fill and granular drainage layer are constructed in accordance with our recommendations, the slab may be designed assuming a modulus of subgrade reaction, k_1 of 125 pci (lbs./cu. inch). The modulus of subgrade reaction value is based on a 1 ft by 1 ft plate load test basis.

Vapor Barrier: Before the placement of concrete, a vapor barrier may be placed on top of the granular drainage layer to provide additional protection against moisture penetration through the floor slab. Surface curing of the slab should be performed in accordance with ACI recommendations to reduce the potential for uneven drying, curling and/or cracking of the slab. Depending on proposed flooring material types, the structural engineer and/or the architect may choose to eliminate the vapor barrier.

Slab Isolation: Ground-supported slabs should be isolated from the foundations and foundation-supported elements of the structures so that differential movement between the foundations and slab will not induce excessive shear and bending stresses in the floor slab. Where the structural configuration (turn down slabs or post tension mats) prevents the use of a free-floating slab, the slab should be designed to avoid overstressing of the slab. Maximum differential settlement of soils supporting interior slabs is anticipated to be less than 0.5 inches in 50 feet.

5.0 SITE CONSTRUCTION RECOMMENDATIONS

5.1 SUBGRADE PREPARATION

5.1.1 Stripping and Grubbing

The subgrade preparation should consist of stripping vegetation, rootmat, topsoil, existing fill, and any soft or unsuitable materials from the 10-foot expanded building and 5-foot expanded pavement limits. Soundings performed in “undisturbed” areas of the site contained an observed approximately 2 inches of topsoil. Deeper topsoil or organic laden soils may be present in wet, low-lying, and poorly drained areas. ECS should be retained to verify that topsoil and unsuitable surficial materials have been removed prior to the placement of structural fill or construction of structures.

5.1.2 Proofrolling

Prior to fill placement or other construction on subgrades, the subgrades should be evaluated by an ECS field technician. The exposed subgrade should be thoroughly proofrolled with construction equipment having a minimum axle load of 10 tons [e.g., fully loaded tandem-axle dump truck]. Proofrolling should be traversed in two perpendicular directions with overlapping passes of the vehicle under the observation of an ECS technician. This procedure is intended to assist in identifying any localized yielding materials.

Where proofrolling identifies areas that are unstable or “pumping” subgrade those areas should be repaired prior to the placement of any subsequent Structural Fill or other construction materials. Methods of stabilization include undercutting and moisture conditioning. The situation should be discussed with ECS to evaluate the appropriate procedure. Test pits may be excavated to explore the shallow subsurface materials to help in evaluating the cause of the observed unstable materials, and to assist in the evaluation of appropriate remedial actions to stabilize the subgrade.

Due to the near surface loose SANDS (SM, SP) encountered in the soundings and hand auger borings, in-place densification may be needed prior to construction of foundations or placement of fill.

5.1.3 Site Temporary Dewatering

Temporary Dewatering: Temporary dewatering operations can be managed by the use of conventional submersible pumps directly in the excavation or temporary trenches to direct the flow of water and to remove water from the excavation. If temporary sump pits are used, we recommend they be established at an elevation 3 to 5 feet below the bottom of the excavation subgrade or bottom of footing. A perforated 55-gallon drum or other temporary structure could be used to house the pump. We recommend continuous dewatering of the excavations using pumps during construction.

If dewater operations are performed at the site, ECS recommends that the dewatering operations be performed in accordance with Local, State and Federal Government regulatory requirements for surface water discharges. ECS would be pleased to be consulted by the client on those requirements, if requested.

5.2 EARTHWORK OPERATIONS

5.2.1 Structural Fill

Prior to placement of structural fill, representative bulk samples (about 50 pounds) of on-site and/or off-site borrow should be submitted to ECS for laboratory testing, which will typically include Atterberg limits, natural moisture content, grain-size distribution, and moisture-density relationships (i.e., Proctors) for compaction. Import materials should be tested prior to being hauled to the site to evaluate if they meet project specifications. Alternatively, Proctor data from other accredited laboratories can be submitted if the test results are within the last 90 days.

Satisfactory Structural Fill Materials: Materials satisfactory for use as structural fill should consist of inorganic soils with the following engineering properties and compaction requirements.

STRUCTURAL FILL INDEX PROPERTIES	
Subject	Property
Building and Pavement Areas	LL < 40, PI < 20
Max. Particle Size	4 inches
Fines Content	Max. 20 %
Max. organic content	5% by dry weight

STRUCTURAL FILL COMPACTION REQUIREMENTS	
Subject	Requirement
Compaction Standard	Standard Proctor, ASTM D698
Required Compaction (Upper 1 foot)	98% of Max. Dry Density
Required Compaction (Depths greater than 1 foot)	95% of Max. Dry Density
Dry Unit Weight	>100 pcf
Moisture Content	-2 to +2 % points of the soil's optimum value
Loose Thickness	8 inches prior to compaction

On-Site Borrow Suitability: Natural deposits of suitable soils are present on the site. The near surface onsite sands (SP, SM) with fines contents less than 20 percent and free of detritus material should be fine for re-use as structural fill.

Fill Placement: Fill materials should not be placed on frozen soils, on frost-heaved soils, and/or on excessively wet soils. Borrow fill materials should not contain frozen materials at the time of placement, and frozen or frost-heaved soils should be removed prior to placement of structural fill or other fill soils and aggregates. Excessively wet soils or aggregates should be scarified, aerated, and moisture conditioned.

5.3 FOUNDATION AND SLAB OBSERVATIONS

Slab Subgrade Verification: Prior to placement of a drainage layer, the subgrade should be prepared in accordance with the recommendations found in **Section 5.1.2 Proofrolling**.

5.4 UTILITY INSTALLATIONS

Utility Subgrades: The soils encountered in our exploration are expected to be generally suitable for support of utility pipes. The pipe subgrades should be observed and probed for stability by ECS. Any loose or unsuitable materials encountered should be removed and replaced with suitable compacted Structural Fill, or pipe stone bedding material.

Utility Backfilling: The granular bedding material (AASHTO #57 stone) should be at least 6 inches thick, but not less than that specified by the civil engineer's project drawings and specifications. We recommend that the bedding materials be placed up to the springline of the pipe. Fill placed for support of the utilities, as well as backfill over the utilities, should satisfy the requirements for structural fill and fill placement.

Excavation Safety: Excavations and slopes should be constructed and maintained in accordance with OSHA excavation safety standards. The contractor is solely responsible for designing, constructing, and maintaining stable temporary excavations and slopes. The contractor's responsible person, as defined in 29 CFR Part 1926, should evaluate the soil exposed in the excavations as part of the contractor's safety procedures. In no case should slope height, slope inclination, or excavation depth, including utility trench excavation depth, exceed those specified in local, state, and federal safety regulations. ECS is providing this information solely as a service to our client. ECS is not assuming responsibility for construction site safety or the contractor's activities; such responsibility is not being implied and should not be inferred.

6.0 CLOSING

ECS has prepared this report to guide the geotechnical-related design and construction aspects of the project. We performed these services in accordance with the standard of care expected of professionals in the industry performing similar services on projects of like size and complexity at this time in the region. No other representation, expressed or implied, and no warranty or guarantee is included or intended in this report.

The description of the proposed project is based on information provided to ECS by Ms. Carol Lurz of Coastal Carolina Community College. If any of this information is inaccurate or changes, either because of our interpretation of the documents provided or site or design changes that may occur later, ECS should be contacted so we can review our recommendations and provide additional or alternate recommendations that reflect the proposed construction.

We recommend that ECS review the project plans and specifications so we can confirm that those plans/specifications are in accordance with the recommendations of this geotechnical report.

Field observations and quality assurance testing during earthwork and foundation installation are an extension of, and integral to, the geotechnical design. We recommend that ECS be retained to apply our expertise throughout the geotechnical phases of construction, and to provide consultation and recommendation should issues arise.

ECS is not responsible for the conclusions, opinions, or recommendations of others based on the data in this report.

APPENDIX A – Diagrams & Reports

Site Location Diagram
Exploration Location Diagram

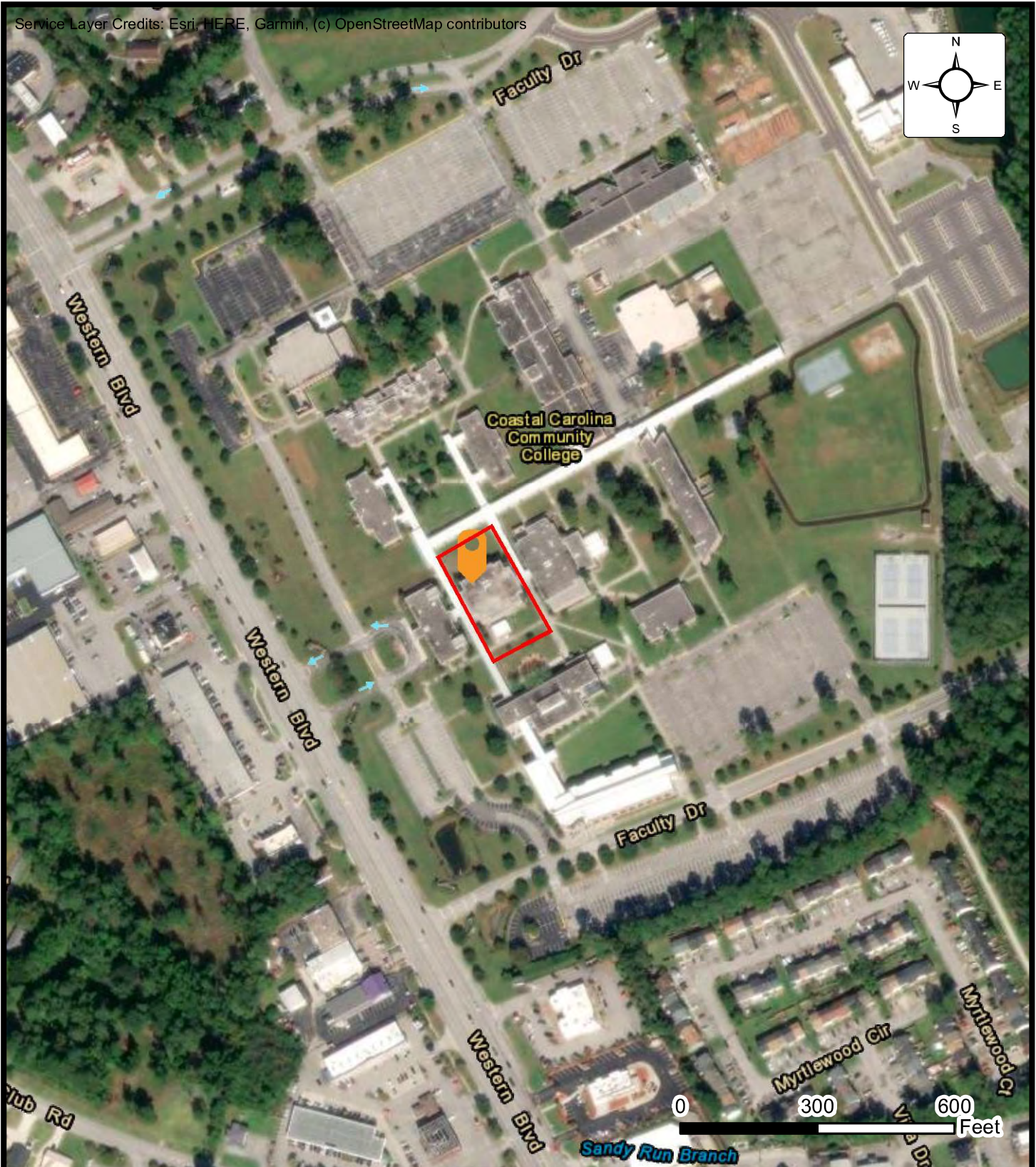

BORING LOCATION DIAGRAM CCCC - LRC 1ST FLOOR RENOVATION

444 WESTERN BLVD, JACKSONVILLE, NC
COASTAL CAROLINA COMMUNITY COLLEGE

ENGINEER WEG
SCALE AS NOTED
PROJECT NO. 22:33881
FIGURE 1 OF 2
DATE 11/2/2023

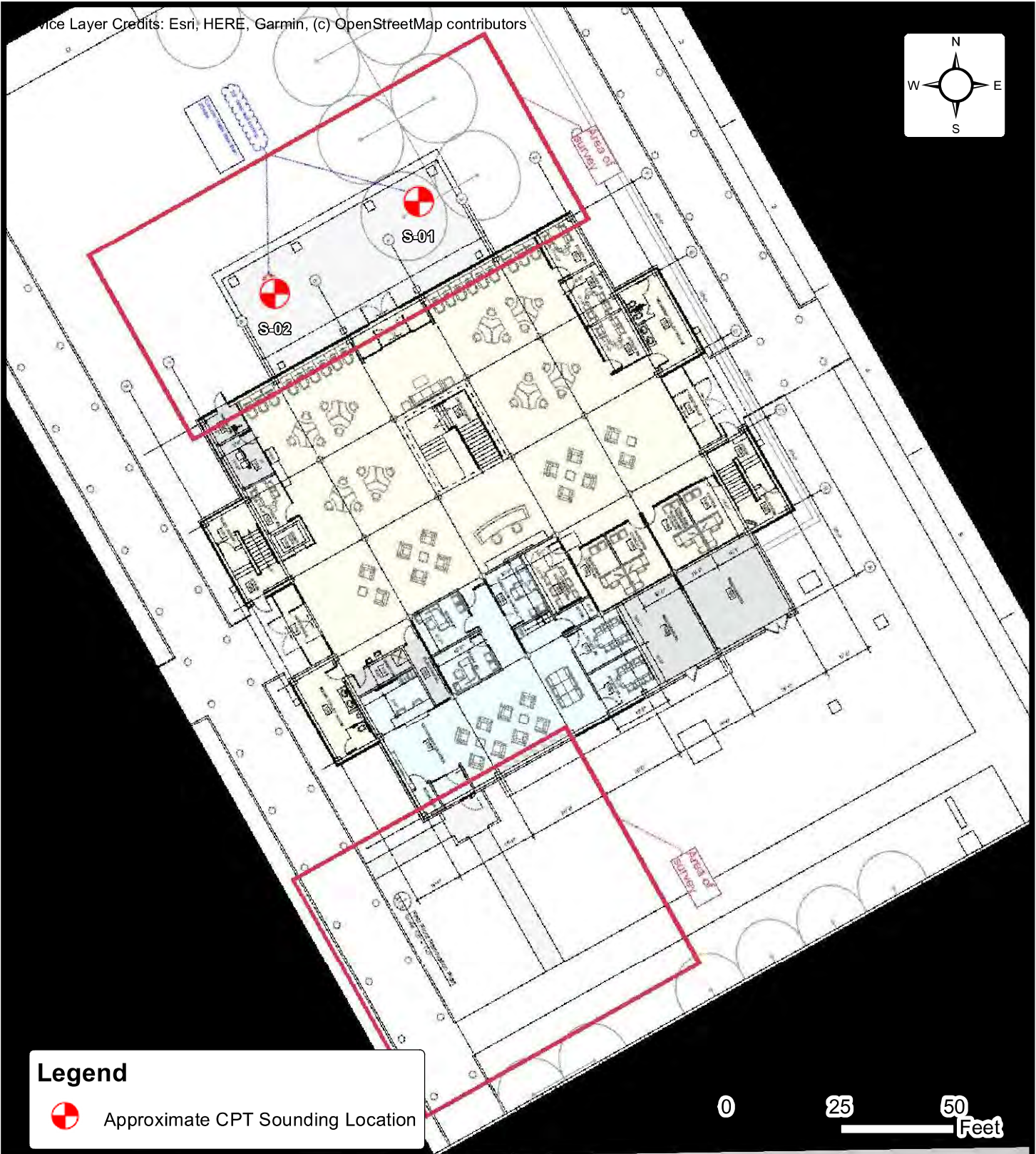
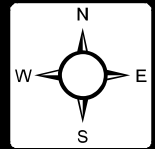

Legend

 Approximate CPT Sounding Location

0 25 50 Feet



**BORING LOCATION DIAGRAM
CCCC - LRC 1ST FLOOR RENOVATION**

444 WESTERN BLVD, JACKSONVILLE, NC

COASTAL CAROLINA COMMUNITY COLLEGE

ENGINEER
WEG

SCALE
AS NOTED

PROJECT NO.
22:33881

FIGURE
2 OF 2

DATE
11/2/2023

APPENDIX B – Field Operations

Reference Notes for CPT Soundings Logs
Cone Penetration Test Sounding Logs (S-1 and S-2)

REFERENCE NOTES FOR CONE PENETRATION TEST (CPT) SOUNDINGS

In the CPT sounding procedure (ASTM-D-5778), an electronically instrumented cone penetrometer is hydraulically advanced through soil to measure point resistance (q_c), pore water pressure (u_2), and sleeve friction (f_s). These values are recorded continuously as the cone is pushed to the desired depth. CPT data is corrected for depth and used to estimate soil classifications and intrinsic soil parameters such as angle of internal friction, preconsolidation pressure, and undrained shear strength. The graphs below represent one of the accepted methods of CPT soil behavior classification (Robertson, 1990).

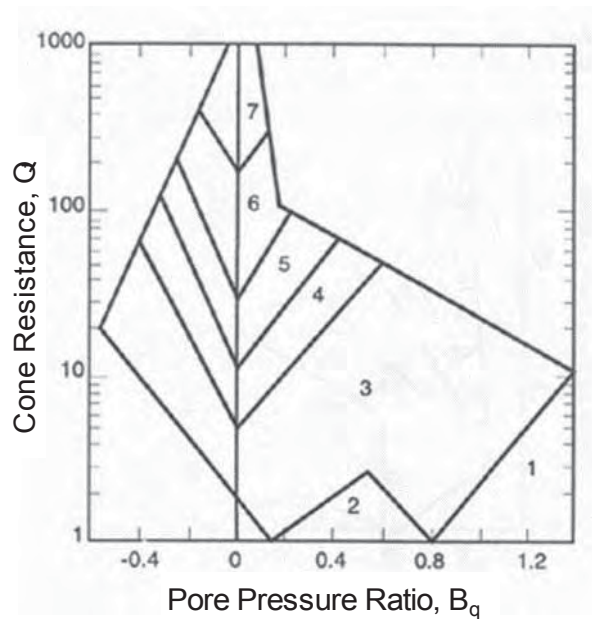
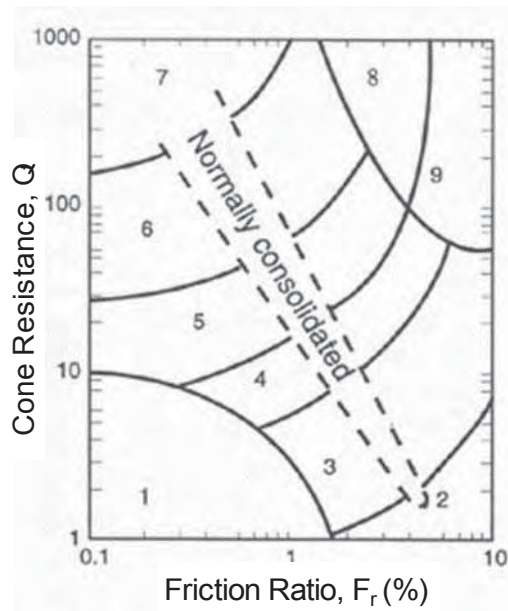

1. Sensitive, Fine Grained
2. Organic Soils-Peats
3. Clays; Clay to Silty Clay
4. Clayey Silt to Silty Clay
5. Silty Sand to Sandy Silt

6. Clean Sands to Silty Sands
7. Gravelly Sand to Sand
8. Very Stiff Sand to Clayey Sand
9. Very Stiff Fine Grained

The following table presents a correlation of corrected cone tip resistance (q_t) to soil consistency or relative density:

SAND		SILT/CLAY	
Corrected Cone Tip Resistance (q_t) (tsf)	Relative Density	Corrected Cone Tip Resistance (q_t) (tsf)	Relative Density
<20	Very Loose	<5	Very Soft
20-40	Loose	5-10	Soft
40-120	Medium Dense	10-15	Firm
		15-30	Stiff
120-200	Dense	30-45	Very Stiff
>200	Very Dense	45-60	Hard
		>60	Very Hard



SUBSURFACE EXPLORATION PROCEDURE: CONE PENETRATION TESTING (CPT) ASTM D 5778

In the CPT sounding procedure, an electronically instrumented cone penetrometer is hydraulically advanced through soil to measure point resistance (qc), pore water pressure (U2), and sleeve friction (fs). These values are recorded continuously as the cone is pushed to the desired depth. CPT data is corrected for depth and used to estimate soil classifications and intrinsic soil parameters such as angle of internal friction, pre-consolidation pressure, and undrained shear strength.

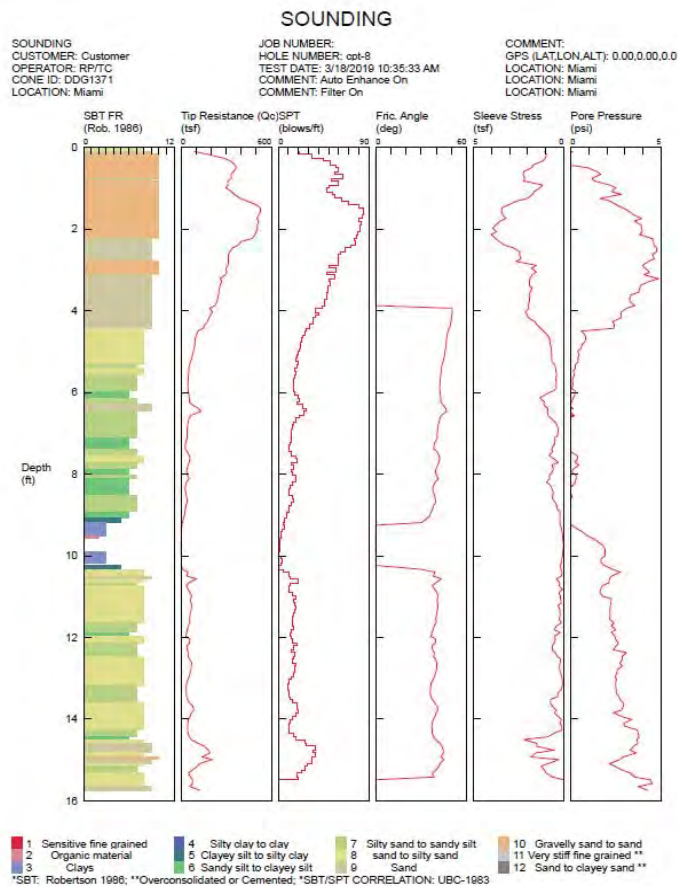

CPT Procedure:

- Involves the direct push of an electronically instrumented cone penetrometer* through the soil
- Values are recorded continuously
- CPT data is corrected and correlated to soil parameters

*CPT Penetrometer Size May Vary



ECS Southeast, LLP
6714 Netherlands Drive
Wilmington, NC 28403
ECS Project # 22-33881

CPT: S-1

Total depth: 34.94 ft, Date: 10/23/2023

Cone Type: Unknown

Cone Operator: Jared Duffy

Project: CCCC- LRC 1st Floor Renovation

Location: Jacksonville, Onslow County, North Carolina

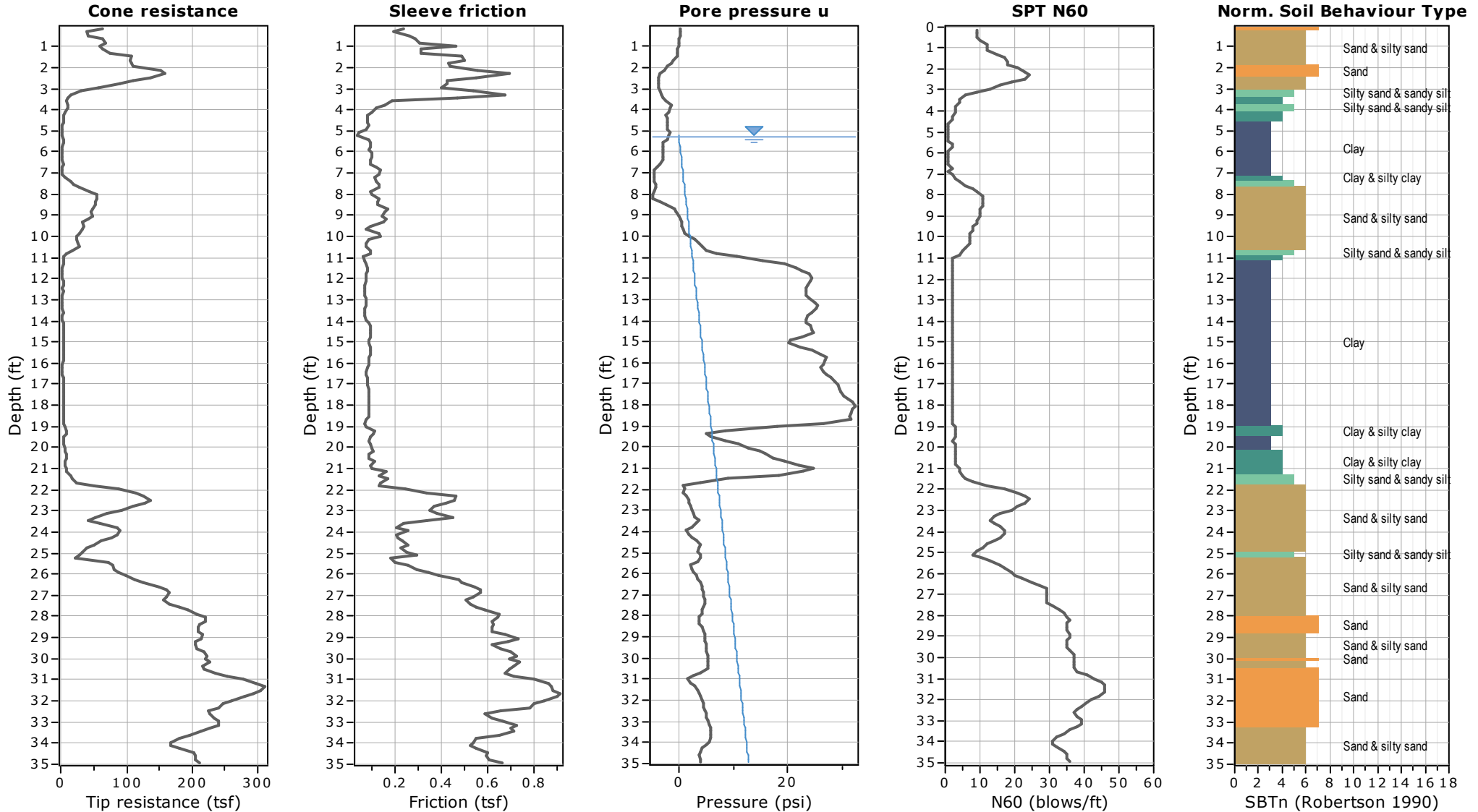



ECS Southeast, LLP
6714 Netherlands Drive
Wilmington, NC 28403
ECS Project # 22-33881

CPT: S-2

Total depth: 34.94 ft, Date: 10/23/2023

Cone Type: Unknown

Cone Operator: Jared Duffy

Project: CCCC- LRC 1st Floor Renovation

Location: Jacksonville, Onslow County, North Carolina

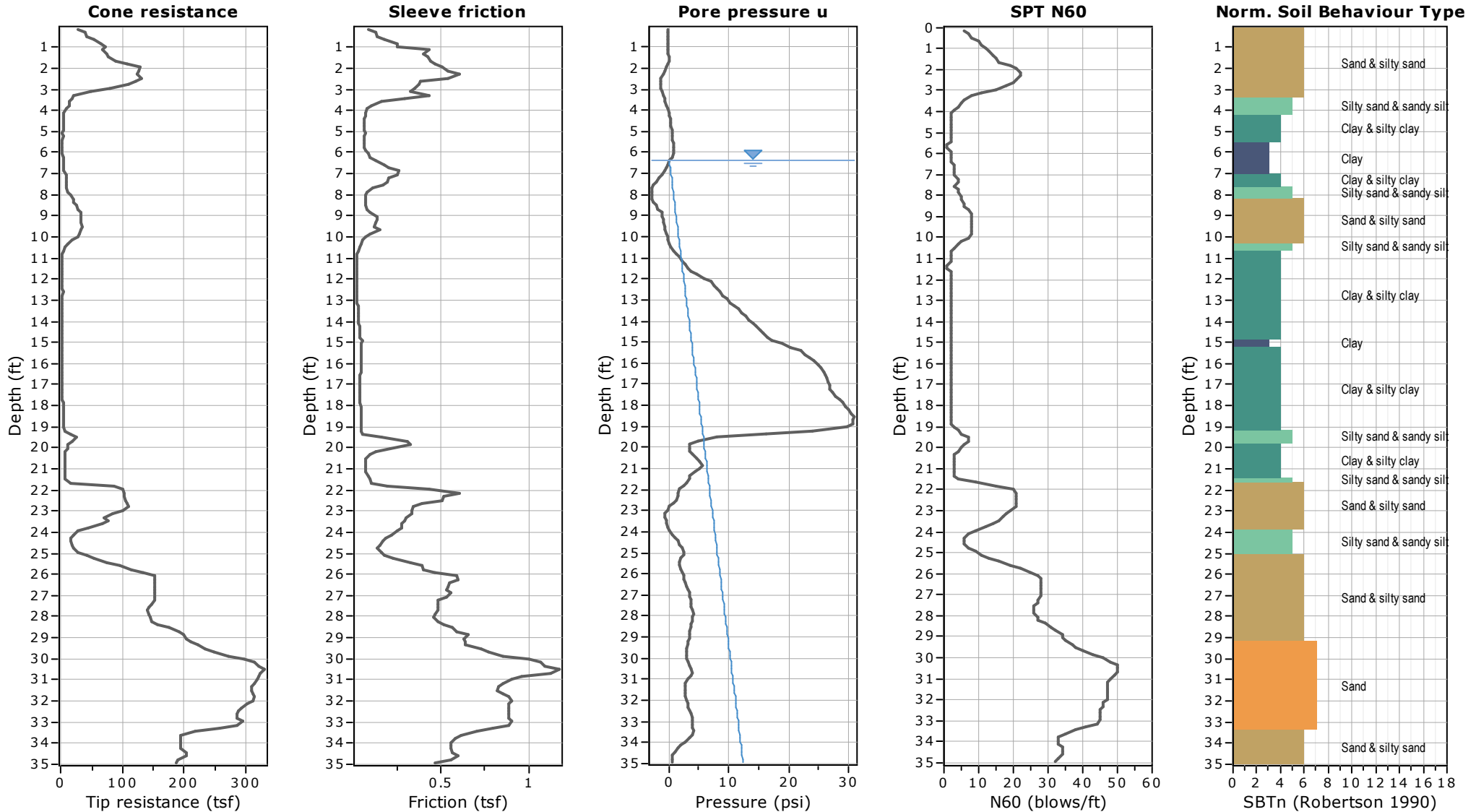

APPENDIX C – Supplemental Report Documents

GBA Document

Important Information about This

Geotechnical-Engineering Report

Subsurface problems are a principal cause of construction delays, cost overruns, claims, and disputes.

While you cannot eliminate all such risks, you can manage them. The following information is provided to help.

The Geoprofessional Business Association (GBA) has prepared this advisory to help you – assumedly a client representative – interpret and apply this geotechnical-engineering report as effectively as possible. In that way, clients can benefit from a lowered exposure to the subsurface problems that, for decades, have been a principal cause of construction delays, cost overruns, claims, and disputes. If you have questions or want more information about any of the issues discussed below, contact your GBA-member geotechnical engineer. Active involvement in the Geoprofessional Business Association exposes geotechnical engineers to a wide array of risk-confrontation techniques that can be of genuine benefit for everyone involved with a construction project.

Geotechnical-Engineering Services Are Performed for Specific Purposes, Persons, and Projects

Geotechnical engineers structure their services to meet the specific needs of their clients. A geotechnical-engineering study conducted for a given civil engineer will not likely meet the needs of a civil-works constructor or even a different civil engineer. Because each geotechnical-engineering study is unique, each geotechnical-engineering report is unique, prepared *solely* for the client. *Those who rely on a geotechnical-engineering report prepared for a different client can be seriously misled.* No one except authorized client representatives should rely on this geotechnical-engineering report without first conferring with the geotechnical engineer who prepared it. *And no one – not even you – should apply this report for any purpose or project except the one originally contemplated.*

Read this Report in Full

Costly problems have occurred because those relying on a geotechnical-engineering report did not read it *in its entirety*. Do not rely on an executive summary. Do not read selected elements only. *Read this report in full.*

You Need to Inform Your Geotechnical Engineer about Change

Your geotechnical engineer considered unique, project-specific factors when designing the study behind this report and developing the confirmation-dependent recommendations the report conveys. A few typical factors include:

- the client's goals, objectives, budget, schedule, and risk-management preferences;
- the general nature of the structure involved, its size, configuration, and performance criteria;
- the structure's location and orientation on the site; and
- other planned or existing site improvements, such as retaining walls, access roads, parking lots, and underground utilities.

Typical changes that could erode the reliability of this report include those that affect:

- the site's size or shape;
- the function of the proposed structure, as when it's changed from a parking garage to an office building, or from a light-industrial plant to a refrigerated warehouse;
- the elevation, configuration, location, orientation, or weight of the proposed structure;
- the composition of the design team; or
- project ownership.

As a general rule, *always* inform your geotechnical engineer of project changes – even minor ones – and request an assessment of their impact. *The geotechnical engineer who prepared this report cannot accept responsibility or liability for problems that arise because the geotechnical engineer was not informed about developments the engineer otherwise would have considered.*

This Report May Not Be Reliable

Do not rely on this report if your geotechnical engineer prepared it:

- for a different client;
- for a different project;
- for a different site (that may or may not include all or a portion of the original site); or
- before important events occurred at the site or adjacent to it; e.g., man-made events like construction or environmental remediation, or natural events like floods, droughts, earthquakes, or groundwater fluctuations.

Note, too, that it could be unwise to rely on a geotechnical-engineering report whose reliability may have been affected by the passage of time, because of factors like changed subsurface conditions; new or modified codes, standards, or regulations; or new techniques or tools. *If your geotechnical engineer has not indicated an "apply-by" date on the report, ask what it should be, and, in general, if you are the least bit uncertain about the continued reliability of this report, contact your geotechnical engineer before applying it.* A minor amount of additional testing or analysis – if any is required at all – could prevent major problems.

Most of the "Findings" Related in This Report Are Professional Opinions

Before construction begins, geotechnical engineers explore a site's subsurface through various sampling and testing procedures. *Geotechnical engineers can observe actual subsurface conditions only at those specific locations where sampling and testing were performed.* The data derived from that sampling and testing were reviewed by your geotechnical engineer, who then applied professional judgment to form opinions about subsurface conditions throughout the site. Actual sitewide-subsurface conditions may differ – maybe significantly – from those indicated in this report. Confront that risk by retaining your geotechnical engineer to serve on the design team from project start to project finish, so the individual can provide informed guidance quickly, whenever needed.

This Report's Recommendations Are Confirmation-Dependent

The recommendations included in this report – including any options or alternatives – are confirmation-dependent. In other words, *they are not final*, because the geotechnical engineer who developed them relied heavily on judgment and opinion to do so. Your geotechnical engineer can finalize the recommendations *only after observing actual subsurface conditions* revealed during construction. If through observation your geotechnical engineer confirms that the conditions assumed to exist actually do exist, the recommendations can be relied upon, assuming no other changes have occurred. *The geotechnical engineer who prepared this report cannot assume responsibility or liability for confirmation-dependent recommendations if you fail to retain that engineer to perform construction observation.*

This Report Could Be Misinterpreted

Other design professionals' misinterpretation of geotechnical-engineering reports has resulted in costly problems. Confront that risk by having your geotechnical engineer serve as a full-time member of the design team, to:

- confer with other design-team members,
- help develop specifications,
- review pertinent elements of other design professionals' plans and specifications, and
- be on hand quickly whenever geotechnical-engineering guidance is needed.

You should also confront the risk of constructors misinterpreting this report. Do so by retaining your geotechnical engineer to participate in prebid and preconstruction conferences and to perform construction observation.

Give Constructors a Complete Report and Guidance

Some owners and design professionals mistakenly believe they can shift unanticipated-subsurface-conditions liability to constructors by limiting the information they provide for bid preparation. To help prevent the costly, contentious problems this practice has caused, include the complete geotechnical-engineering report, along with any attachments or appendices, with your contract documents, *but be certain to note conspicuously that you've included the material for informational purposes only*. To avoid misunderstanding, you may also want to note that "informational purposes" means constructors have no right to rely on the interpretations, opinions, conclusions, or recommendations in the report, but they may rely on the factual data relative to the specific times, locations, and depths/elevations referenced. Be certain that constructors know they may learn about specific project requirements, including options selected from the report, *only* from the design drawings and specifications. Remind constructors that they may

perform their own studies if they want to, and *be sure to allow enough time* to permit them to do so. Only then might you be in a position to give constructors the information available to you, while requiring them to at least share some of the financial responsibilities stemming from unanticipated conditions. Conducting prebid and preconstruction conferences can also be valuable in this respect.

Read Responsibility Provisions Closely

Some client representatives, design professionals, and constructors do not realize that geotechnical engineering is far less exact than other engineering disciplines. That lack of understanding has nurtured unrealistic expectations that have resulted in disappointments, delays, cost overruns, claims, and disputes. To confront that risk, geotechnical engineers commonly include explanatory provisions in their reports. Sometimes labeled "limitations," many of these provisions indicate where geotechnical engineers' responsibilities begin and end, to help others recognize their own responsibilities and risks. *Read these provisions closely*. Ask questions. Your geotechnical engineer should respond fully and frankly.

Geoenvironmental Concerns Are Not Covered

The personnel, equipment, and techniques used to perform an environmental study – e.g., a "phase-one" or "phase-two" environmental site assessment – differ significantly from those used to perform a geotechnical-engineering study. For that reason, a geotechnical-engineering report does not usually relate any environmental findings, conclusions, or recommendations; e.g., about the likelihood of encountering underground storage tanks or regulated contaminants. *Unanticipated subsurface environmental problems have led to project failures*. If you have not yet obtained your own environmental information, ask your geotechnical consultant for risk-management guidance. As a general rule, *do not rely on an environmental report prepared for a different client, site, or project, or that is more than six months old*.

Obtain Professional Assistance to Deal with Moisture Infiltration and Mold

While your geotechnical engineer may have addressed groundwater, water infiltration, or similar issues in this report, none of the engineer's services were designed, conducted, or intended to prevent uncontrolled migration of moisture – including water vapor – from the soil through building slabs and walls and into the building interior, where it can cause mold growth and material-performance deficiencies. Accordingly, *proper implementation of the geotechnical engineer's recommendations will not of itself be sufficient to prevent moisture infiltration*. Confront the risk of moisture infiltration by including building-envelope or mold specialists on the design team. *Geotechnical engineers are not building-envelope or mold specialists*.



Telephone: 301/565-2733

e-mail: info@geoprofessional.org www.geoprofessional.org

FORM OF PROPOSAL

Learning Resources Center First Floor Renovation
Coastal Carolina Community College
SCO ID#: 23-26060-01A

Contract: General
Bidder: _____
Date: _____

The undersigned, as bidder, hereby declares that the only person or persons interested in this proposal as principal or principals is or are named herein and that no other person than herein mentioned has any interest in this proposal or in the contract to be entered into; that this proposal is made without connection with any other person, company or parties making a bid or proposal; and that it is in all respects fair and in good faith without collusion or fraud. The bidder further declares that he has examined the site of the work and the contract documents relative thereto and has read all special provisions furnished prior to the opening of bids; that he has satisfied himself relative to the work to be performed. The bidder further declares that he and his subcontractors have fully complied with NCGS 64, Article 2 in regard to E-Verification as required by Section 2.(c) of Session Law 2013-418, codified as N.C. Gen. Stat. § 143-129(j).

The Bidder proposes and agrees if this proposal is accepted to contract with the

Coastal Carolina Community College

in the form of contract specified below, to furnish all necessary materials, equipment, machinery, tools, apparatus, means of transportation and labor necessary to complete the construction of

Learning Resources Center First Floor Renovation

in full in complete accordance with the plans, specifications and contract documents, to the full and entire satisfaction of Coastal Carolina Community College and Bowman Murray Hemingway Architects with a definite understanding that no money will be allowed for extra work except as set forth in the General Conditions and the contract documents, for the sum of:

SINGLE PRIME CONTRACT:

TOTAL BASE BID:

_____ Dollars(\$)

General Subcontractor:
_____ Lic _____

Plumbing Subcontractor:
_____ Lic _____

Mechanical Subcontractor:
_____ Lic _____

Electrical Subcontractor:
_____ Lic _____

GS143-128(d) requires all single prime bidders to identify their subcontractors for the above subdivisions of work. A contractor whose bid is accepted shall not substitute any person as subcontractor in the place of the subcontractor listed in the original bid, except (i) if the listed subcontractor's bid is later determined by the contractor to be non-responsible or non-responsive or the listed subcontractor refuses to enter into a contract for the complete performance of the bid work, or (ii) with the approval of the awarding authority for good cause shown by the contractor.

ALTERNATES:

Should any of the alternates as described in the contract documents be accepted, the amount written below shall be the amount to be "added to" or "deducted from" the base bid.

GENERAL CONTRACT:

Project Scope Alternates:

Alternate #1: State amount to be added to the base bid to provide all labor and material to provide Covered Canopy 140. Alternate to include all architectural, structural, plumbing, mechanical and electrical work involved in construction of Covered Canopy 140 as shown on A2.0 and A3.0. Base bid to include doors 134B and sidewalks as shown on A2.1. Base bid to include infiltration trenches as delineated on civil drawings.

(Add) _____ Dollars(\$)

Alternate #2: State the amount to be added to the base bid to provide labor and material for the complete installation of a standby power system including new natural gas fueled engine-generator set, automatic transfer switch and associated conductors, conduit and equipment as shown on electrical and plumbing drawings in the construction documents.

(Add) _____ Dollars(\$)

Alternate #3: State the amount to be added to the base bid to provide labor and material for precast terrazzo treads and risers and precast terrazzo tiles as delineated at the central stair on drawing sheet A5.0 and in specific section 096623 Resinous Matrix Terrazzo Flooring. Work to include removal of metal nosing at existing stair treads. Base bid shall include sheet carpeting at central stair as specified.

(Add) _____ Dollars(\$)

Owner Preferred Brand Alternates:

Alternate #4: State the amount to be added to the base bid to provide the basis of design door hardware as specified in section 087100:

Hinges and Butts:	McKinney: TB2714/TB2314/T4B3786/T4B3386
Continuous Hinges:	Ives: 224HD
Cylinders and Keying:	Corbin Russwin
Mortise Locks:	Corbin Russwin ML2000 x LWA
Cylindrical Locks:	Corbin Russwin CL3300 Series
Door Closers:	LCN 4040XP/4040XP
Exit Devices:	Von Duprin 99 Series

(Add) _____ Dollars(\$)

Alternate #5: State the amount to be added to the base bid to provide Sliding Automatic Entrances by Stanley Automatic Sliding Doors as specified in Section 084232.

(Add) _____ Dollars(\$)

Alternate #6: State the amount to be added to the base bid to provide fire alarm systems and devices by Notifier as specified in section 283111.

(Add) _____ Dollars(\$)

Alternate #7: State the amount to be added to the base bid to provide Schneider Electric DDC system as specified in section 230923 DIRECT DIGITAL CONTROL SYSTEM FOR HVAC, drawing M7.1, and drawing M7.2.

(Add) _____ Dollars(\$)

Alternate #8: State the amount to be added to the base bid to provide telecommunication structured cabling systems and devices by Amp Netconnect as specified in section 271500.

(Add) _____ Dollars(\$)

Alternate #9: State the amount to be added to the base bid to provide the basis of design plumbing fixtures as scheduled on drawing P0.2:

1. WC-1 ADA Water Closet: American Standard 3043.001.020, Sloan 111-1.28-DFB, Bemis Manufacturing Co. 1955SSCT.
2. WC-2 Water Closet: American Standard 2234.001.020, Sloan 113-1.28-DFB-Z, Bemis Manufacturing Co. 1955SSCT.
3. UR-1 Urinal: American Standard 6590001.020, Sloan 186-0.125-DBP, Zurn Z1221-UNIV.
4. LAV-1 ADA Lavatory: American Standard 0497.221.020, Moen 8894, Jones Stephens D70100.
5. SK-1 2-Compartment Sink: Elkay LR33223, Moen 8701, Elkay LK35.
6. FD-1 Floor Drain: Sioux Chief 832-4PNR.
7. HB-1 Hose Bibb: Woodford 24P.
8. OB-1 Ice Maker Box: Sioux Chief 696-G1010XF.

(Add) _____ Dollars(\$)

Alternate #10: State the amount to be added to the base bid to provide Trane EXHG Ground-coupled heat pumps as scheduled on drawing M6.1.

(Add) _____ Dollars(\$)

Alternate #11: State the amount to be added to the base bid to provide elevator modernization to the main elevator in the Learning Resources Center Building (TKE Serial # US155244) by **TKE** as specified in section 142400.5 Hydraulic Elevator Modernization.

(Add) _____ Dollars(\$)

UNIT PRICES

Unit prices quoted and accepted shall apply throughout the life of the contract, except as otherwise specifically noted. Unit prices shall be applied, as appropriate, to compute the total value of changes in the base bid quantity of the work all in accordance with the contract documents.

Unit Price 1: Removal of unsuitable soils per cubic yard and replacement with compacted sand. Contractor shall provide loading and hauling to site and disposal of unsuitable soils.

\$ _____ Per CY

Unit Price 2: Removal of unsuitable soils per cubic yard and replacement with No. 57 Stone. Contractor shall provide loading and hauling to site and disposal of unsuitable soils.

\$ _____ Per CY

Unit Price 3: Removal of unsuitable soils per cubic yard and replacement with ABC stone. Contractor shall provide loading and hauling to site and disposal of unsuitable soils.

\$ _____ Per CY

MINORITY BUSINESS PARTICIPATION REQUIREMENTS

Provide with the bid - Under GS 143-128.2(c) the undersigned bidder shall identify **on its bid** (Identification of Minority Business Participation Form) the minority businesses that it will use on the project with the total dollar value of the bids that will be performed by the minority businesses. **Also** list the good faith efforts (Affidavit **A**) made to solicit minority participation in the bid effort.

NOTE: A contractor that performs all of the work with its own workforce may submit an Affidavit (**B**) to that effect in lieu of Affidavit (**A**) required above. The MB Participation Form must still be submitted even if there is zero participation.

After the bid opening - The Owner will consider all bids and alternates and determine the lowest responsible, responsive bidder. Upon notification of being the apparent low bidder, the bidder shall then file within 72 hours of the notification of being the apparent lowest bidder, the following:

An Affidavit (**C**) that includes a description of the portion of work to be executed by minority businesses, expressed as a percentage of the total contract price, which is equal to or more than the 10% goal established. This affidavit shall give rise to the presumption that the bidder has made the required good faith effort and Affidavit **D** is not necessary;

*** OR ***

If less than the 10% goal, Affidavit (**D**) of its good faith effort to meet the goal shall be provided. The document must include evidence of all good faith efforts that were implemented, including any advertisements, solicitations and other specific actions demonstrating recruitment and selection of minority businesses for participation in the contract.

Note: Bidders must always submit **with their bid** the Identification of Minority Business Participation Form listing all MB contractors, vendors and suppliers that will be used. If there is no MB participation, then enter none or zero on the form. Affidavit **A** or Affidavit **B**, as applicable, also must be submitted with the bid. Failure to file a required affidavit or documentation with the bid or after being notified apparent low bidder is grounds for rejection of the bid.

Proposal Signature Page

The undersigned further agrees that in the case of failure on his part to execute the said contract and the bonds within ten (10) consecutive calendar days after being given written notice of the award of contract, the certified check, cash or bid bond accompanying this bid shall be paid into the funds of the owner's account set aside for the project, as liquidated damages for such failure; otherwise the certified check, cash or bid bond accompanying this proposal shall be returned to the undersigned.

Respectfully submitted this day of _____

(Name of firm or corporation making bid)

WITNESS:

By: _____
Signature

(Proprietorship or Partnership)

Name: _____
Print or type

Title _____
(Owner/Partner/Pres./V.Pres)

Address _____

ATTEST:

By: _____

License No. _____

Title: _____
(Corp. Sec. or Asst. Sec. only)

Federal I.D. No. _____

Email Address: _____

(CORPORATE SEAL)

Addendum received and used in computing bid:

Addendum No. 1 _____ Addendum No. 3 _____ Addendum No. 5 _____ Addendum No. 6 _____

Addendum No. 2 _____ Addendum No. 4 _____ Addendum No. 6 _____ Addendum No. 7 _____

Identification of HUB Certified/ Minority Business Participation

I, _____,
(Name of Bidder)

do hereby certify that on this project, we will use the following HUB Certified/ minority business as construction subcontractors, vendors, suppliers or providers of professional services.

Firm Name, Address and Phone #	Work Type	*Minority Category	**HUB Certified (Y/N)

*Minority categories: Black, African American (**B**), Hispanic (**H**), Asian American (**A**) American Indian (**I**), Female (**F**) Socially and Economically Disadvantaged (**D**)

**** HUB Certification with the state HUB Office required to be counted toward state participation goals.**

The total value of minority business contracting will be (\$)_____.

State of North Carolina AFFIDAVIT A – Listing of Good Faith Efforts

County of _____

(Name of Bidder)

Affidavit of _____

I have made a good faith effort to comply under the following areas checked:

Bidders must earn at least 50 points from the good faith efforts listed for their bid to be considered responsive. (1 NC Administrative Code 30 I.0101)

- 1 – (10 pts)** Contacted minority businesses that reasonably could have been expected to submit a quote and that were known to the contractor, or available on State or local government maintained lists, at least 10 days before the bid date and notified them of the nature and scope of the work to be performed.
- 2 --(10 pts)** Made the construction plans, specifications and requirements available for review by prospective minority businesses, or providing these documents to them at least 10 days before the bids are due.
- 3 – (15 pts)** Broken down or combined elements of work into economically feasible units to facilitate minority participation.
- 4 – (10 pts)** Worked with minority trade, community, or contractor organizations identified by the Office of Historically Underutilized Businesses and included in the bid documents that provide assistance in recruitment of minority businesses.
- 5 – (10 pts)** Attended prebid meetings scheduled by the public owner.
- 6 – (20 pts)** Provided assistance in getting required bonding or insurance or provided alternatives to bonding or insurance for subcontractors.
- 7 – (15 pts)** Negotiated in good faith with interested minority businesses and did not reject them as unqualified without sound reasons based on their capabilities. Any rejection of a minority business based on lack of qualification should have the reasons documented in writing.
- 8 – (25 pts)** Provided assistance to an otherwise qualified minority business in need of equipment, loan capital, lines of credit, or joint pay agreements to secure loans, supplies, or letters of credit, including waiving credit that is ordinarily required. Assisted minority businesses in obtaining the same unit pricing with the bidder's suppliers in order to help minority businesses in establishing credit.
- 9 – (20 pts)** Negotiated joint venture and partnership arrangements with minority businesses in order to increase opportunities for minority business participation on a public construction or repair project when possible.
- 10 - (20 pts)** Provided quick pay agreements and policies to enable minority contractors and suppliers to meet cash-flow demands.

The undersigned, if apparent low bidder, will enter into a formal agreement with the firms listed in the Identification of Minority Business Participation schedule conditional upon scope of contract to be executed with the Owner. Substitution of contractors must be in accordance with GS143-128.2(d) Failure to abide by this statutory provision will constitute a breach of the contract.

The undersigned hereby certifies that he or she has read the terms of the minority business commitment and is authorized to bind the bidder to the commitment herein set forth.

Date: _____ Name of Authorized Officer: _____

Signature: _____

Title: _____

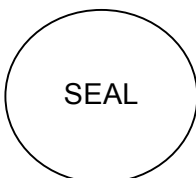

State of _____, County of _____

Subscribed and sworn to before me this _____ day of _____ 20____

Notary Public _____

My commission expires _____

State of North Carolina --AFFIDAVIT B-- Intent to Perform Contract with Own Workforce.

County of _____

Affidavit of _____
(Name of Bidder)

I hereby certify that it is our intent to perform 100% of the work required for the _____ contract.
(Name of Project)

In making this certification, the Bidder states that the Bidder does not customarily subcontract elements of this type project, and normally performs and has the capability to perform and will perform all elements of the work on this project with his/her own current work forces; and

The Bidder agrees to provide any additional information or documentation requested by the owner in support of the above statement. The Bidder agrees to make a Good Faith Effort to utilize minority suppliers where possible.

The undersigned hereby certifies that he or she has read this certification and is authorized to bind the Bidder to the commitments herein contained.

Date: _____ Name of Authorized Officer: _____

Signature: _____

Title: _____

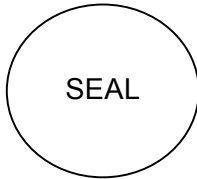

State of _____, County of _____

Subscribed and sworn to before me this _____ day of _____ 20__

Notary Public _____

My commission expires _____

SEAL

Do not submit with bid Do not submit with bid Do not submit with bid Do not submit with bid

State of North Carolina - AFFIDAVIT C - Portion of the Work to be Performed by HUB Certified/Minority Businesses

County of _____

(Note this form is to be submitted only by the apparent lowest responsible, responsive bidder.)

If the portion of the work to be executed by HUB certified/minority businesses as defined in GS143-128.2(g) and 128.4(a),(b),(e) is equal to or greater than 10% of the bidders total contract price, then the bidder must complete this affidavit.
This affidavit shall be provided by the apparent lowest responsible, responsive bidder within **72 hours** after notification of being low bidder.

Affidavit of _____ I do hereby certify that on the _____
(Name of Bidder)

_____ (Project Name)
Project ID# _____ Amount of Bid \$ _____

I will expend a minimum of _____ % of the total dollar amount of the contract with minority business enterprises. Minority businesses will be employed as construction subcontractors, vendors, suppliers or providers of professional services. Such work will be subcontracted to the following firms listed below. Attach additional sheets if required

Name and Phone Number	*Minority Category	**HUB Certified Y/N	Work Description	Dollar Value

*Minority categories: Black, African American (**B**), Hispanic (**H**), Asian American (**A**) American Indian (**I**), Female (**F**) Socially and Economically Disadvantaged (**D**)

**** HUB Certification with the state HUB Office required to be counted toward state participation goals.**

Pursuant to GS143-128.2(d), the undersigned will enter into a formal agreement with Minority Firms for work listed in this schedule conditional upon execution of a contract with the Owner. Failure to fulfill this commitment may constitute a breach of the contract.

The undersigned hereby certifies that he or she has read the terms of this commitment and is authorized to bind the bidder to the commitment herein set forth.

Date: _____ Name of Authorized Officer: _____

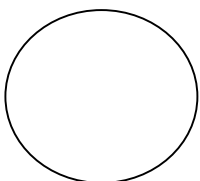

Signature: _____

Title: _____

State of _____, County of _____

Subscribed and sworn to before me this _____ day of _____ 20____

Notary Public _____

My commission expires _____

State of North Carolina AFFIDAVIT D – Good Faith Efforts

County of _____

(Note this form is to be submitted only by the apparent lowest responsible, responsive bidder.)

If the goal of 10% participation by HUB Certified/ minority business **is not** achieved, the Bidder shall provide the following documentation to the Owner of his good faith efforts:

Affidavit of _____ I do hereby certify that on the _____
 (Name of Bidder)

Project ID# _____ (Project Name) Amount of Bid \$ _____

I will expend a minimum of _____% of the total dollar amount of the contract with HUB certified/ minority business enterprises. Minority businesses will be employed as construction subcontractors, vendors, suppliers or providers of professional services. Such work will be subcontracted to the following firms listed below. (Attach additional sheets if required)

Name and Phone Number	*Minority Category	**HUB Certified Y/N	Work Description	Dollar Value

*Minority categories: Black, African American (**B**), Hispanic (**H**), Asian American (**A**) American Indian (**I**), Female (**F**) Socially and Economically Disadvantaged (**D**)

**** HUB Certification with the state HUB Office required to be counted toward state participation goals.**

Examples of documentation that may be required to demonstrate the Bidder's good faith efforts to meet the goals set forth in these provisions include, but are not necessarily limited to, the following:

- A. Copies of solicitations for quotes to at least three (3) minority business firms from the source list provided by the State for each subcontract to be let under this contract (if 3 or more firms are shown on the source list). Each solicitation shall contain a specific description of the work to be subcontracted, location where bid documents can be reviewed, representative of the Prime Bidder to contact, and location, date and time when quotes must be received.
- B. Copies of quotes or responses received from each firm responding to the solicitation.
- C. A telephone log of follow-up calls to each firm sent a solicitation.
- D. For subcontracts where a minority business firm is not considered the lowest responsible sub-bidder, copies of quotes received from all firms submitting quotes for that particular subcontract.
- E. Documentation of any contacts or correspondence to minority business, community, or contractor organizations in an attempt to meet the goal.
- F. Copy of pre-bid roster
- G. Letter documenting efforts to provide assistance in obtaining required bonding or insurance for minority business.
- H. Letter detailing reasons for rejection of minority business due to lack of qualification.
- I. Letter documenting proposed assistance offered to minority business in need of equipment, loan capital, lines of credit, or joint pay agreements to secure loans, supplies, or letter of credit, including waiving credit that is ordinarily required.

Failure to provide the documentation as listed in these provisions may result in rejection of the bid and award to the next lowest responsible and responsive bidder.

Pursuant to GS143-128.2(d), the undersigned will enter into a formal agreement with Minority Firms for work listed in this schedule conditional upon execution of a contract with the Owner. Failure to fulfill this commitment may constitute a breach of the contract.

SEAL Do not submit with the bid Do not submit with the bid Do not submit with the bid Do not submit with the bid Do not submit with the bid

The undersigned hereby certifies that he or she has read the terms of this commitment and is authorized to bind the bidder to the commitment herein set forth.

Date: _____ Name of Authorized Officer: _____

Signature: _____

Title: _____

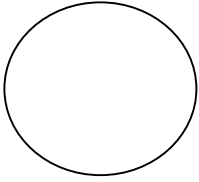

State of _____, County of _____

Subscribed and sworn to before me this _____ day of _____ 20____

Notary Public _____

My commission expires _____

FORM OF BID BOND

KNOW ALL MEN BY THESE PRESENTS THAT _____

_____ as principal, and _____, as surety, who is duly licensed to act as surety in North Carolina, are held and firmly bound unto the State of North Carolina* through _____ as obligee, in the penal sum of _____ DOLLARS, lawful money of the United States of America, for the payment of which, well and truly to be made, we bind ourselves, our heirs, executors, administrators, successors and assigns, jointly and severally, firmly by these presents.

Signed, sealed and dated this ____ day of ____ 20__

WHEREAS, the said principal is herewith submitting proposal for and the principal desires to file this bid bond in lieu of making the cash deposit as required by G.S. 143-129.

NOW, THEREFORE, THE CONDITION OF THE ABOVE OBLIGATION is such, that if the principal shall be awarded the contract for which the bid is submitted and shall execute the contract and give bond for the faithful performance thereof within ten days after the award of same to the principal, then this obligation shall be null and void; but if the principal fails to so execute such contract and give performance bond as required by G.S. 143-129, the surety shall, upon demand, forthwith pay to the obligee the amount set forth in the first paragraph hereof. Provided further, that the bid may be withdrawn as provided by G.S. 143-129.1

_____(SEAL)

_____(SEAL)

_____(SEAL)

_____(SEAL)

_____(SEAL)

FORM OF CONSTRUCTION CONTRACT

(ALL PRIME CONTRACTS)

THIS AGREEMENT, made the _____ day of _____ in the year of 20__ by _____ and _____ between _____ hereinafter called the Party of the First Part and the _____ hereinafter called the Party of the Second Part.

WITNESSETH:

That the Party of the First Part and the Party of the Second Part for the consideration herein named agree as follows:

1. Scope of Work: The Party of the First Part shall furnish and deliver all of the materials, and perform all of the work in the manner and form as provided by the following enumerated plans, specifications and documents, which are attached hereto and made a part thereof as if fully contained herein: advertisement; Instructions to Bidders; General Conditions; Supplementary General Conditions; specifications; accepted proposal; contract; performance bond; payment bond; power of attorney; workmen's compensation; public liability; property damage and builder's risk insurance certificates; approval of attorney general; certificate by the Office of State Budget and Management, and drawings, titled:

Consisting of the following sheets: _____

Dated: _____ and the following addenda:

Addendum No. _____ Dated: _____ Addendum No. _____ Dated: _____

Addendum No. _____ Dated: _____ Addendum No. _____ Dated: _____

Addendum No. _____ Dated: _____ Addendum No. _____ Dated: _____

Addendum No. _____ Dated: _____ Addendum No. _____ Dated: _____

2. That the Party of the First Part shall commence work to be performed under this agreement on a date to be specified in a written order of the Party of the Second Part and shall fully complete all work hereunder within _____ consecutive calendar days

from said date. For each day in excess thereof, liquidated damages shall be as stated in Supplementary General Conditions. The Party of the First Part, as one of the considerations for the awarding of this contract, shall furnish to the Party of the Second Part a construction schedule setting forth planned progress of the project broken down by the various divisions or part of the work and by calendar days as outlined in Article 14 of the General Conditions of the Contract.

3. The Party of the Second Part hereby agrees to pay to the Party of the First Part for the faithful performance of this agreement, subject to additions and deductions as provided in the specifications or proposal, in lawful money of the United States as follows:

_____ (\$ _____).

Summary of Contract Award:

4. In accordance with Article 31 and Article 32 of the General Conditions of the Contract, the Party of the Second Part shall review, and if approved, process the Party of the First Party's pay request within 30 days upon receipt from the Designer. The Party of the Second Part, after reviewing and approving said pay request, shall make payments to the Party of the First Part on the basis of a duly certified and approved estimate of work performed during the preceding calendar month by the First Party, less five percent (5%) of the amount of such estimate which is to be retained by the Second Party until all work has been performed strictly in accordance with this agreement and until such work has been accepted by the Second Party. The Second Party may elect to waive retainage requirements after 50 percent of the work has been satisfactorily completed on schedule as referred to in Article 31 of the General Conditions.

5. Upon submission by the First Party of evidence satisfactory to the Second Party that all payrolls, material bills and other costs incurred by the First Party in connection with the construction of the work have been paid in full, final payment on account of this agreement shall be made within thirty (30) days after the completion by the First Party of all work covered by this agreement and the acceptance of such work by the Second Party.

6. It is further mutually agreed between the parties hereto that if at any time after the execution of this agreement and the surety bonds hereto attached for its faithful performance, the Second Party shall deem the surety or sureties upon such bonds to be unsatisfactory, or if, for any reason, such bonds cease to be adequate to cover the performance of the work, the First Party shall, at its expense, within five (5) days after the receipt of notice from the Second Party so to do, furnish an additional bond or bonds in such form and amount, and with such surety or sureties as shall be satisfactory to the Second Party. In such event no further payment to the First Party shall be deemed to be due under this agreement until such new or additional security for the faithful performance of the work shall be furnished in manner and form satisfactory to the Second Party.

7. The Party of the First Part attest that it and all of its subcontractors have fully complied with all requirements of NCGS 64 Article 2 in regards to E-Verification as required by Section 2.(c) of Session Law 2013-418, codified as N.C. Gen. Stat. § 143-129(j).

IN WITNESS WHEREOF, the Parties hereto have executed this agreement on the day and date first above written in _____ counterparts, each of which shall without proof or accounting for other counterparts, be deemed an original contract.

Witness:

Contractor: (Trade or Corporate Name)

(Proprietorship or Partnership)

By: _____

Title: _____
(Owner, Partner, or Corp. Pres. or Vice Pres. only)

Attest: (Corporation)

By: _____

Title: _____
(Corp. Sec. or Asst. Sec. only)

(CORPORATE SEAL)

(Agency, Department or Institution)

Witness:

By: _____

Title: _____

FORM OF PERFORMANCE BOND

Date of Contract: _____

Date of Execution: _____

Name of Principal
(Contractor) _____

Name of Surety: _____

Name of Contracting
Body: _____

Amount of Bond: _____

Project

KNOW ALL MEN BY THESE PRESENTS, that we, the principal and surety above named, are held and firmly bound unto the above named contracting body, hereinafter called the contracting body, in the penal sum of the amount stated above for the payment of which sum well and truly to be made, we bind, ourselves, our heirs, executors, administrators, and successors, jointly and severally, firmly by these presents.

THE CONDITION OF THIS OBLIGATION IS SUCH, that whereas the principal entered into a certain contract with the contracting body, identified as shown above and hereto attached:

NOW, THEREFORE, if the principal shall well and truly perform and fulfill all the undertakings, covenants, terms, conditions and agreements of said contract during the original term of said contract and any extensions thereof that may be granted by the contracting body, with or without notice to the surety, and during the life of any guaranty required under the contract, and shall also well and truly perform and fulfill all the undertakings, covenants, terms, conditions and agreements of any and all duly authorized modifications of said contract that may hereafter be made, notice of which modifications to the surety being hereby waived, then, this obligation to be void; otherwise to remain in full force and virtue.

IN WITNESS WHEREOF, the above-bounden parties have executed this instrument under their several seals on the date indicated above, the name and corporate seal of each corporate party being hereto affixed and these presents duly signed by its undersigned representative, pursuant to authority of its governing body.

Executed in _____ counterparts.

Witness:

(Proprietorship or Partnership)

Attest: (Corporation)

By: _____

Title: _____
(Corp. Sec. or Asst. Sec. only)

(Corporate Seal)

Contractor: (Trade or Corporate Name)

By: _____

Title: _____
(Owner, Partner, or Corp. Pres. or Vice Pres. only)

(Surety Company)

By: _____

Title: _____
(Attorney in Fact)

(Surety Corporate Seal)

Witness:

Countersigned:

(N.C. Licensed Resident Agent)

Name and Address-Surety Agency

Surety Company Name and N.C.
Regional or Branch Office Address

FORM OF PAYMENT BOND

Date of Contract: _____
Date of Execution: _____
Name of Principal
(Contractor) _____
Name of Surety: _____
Name of Contracting
Body: _____
Amount of Bond: _____
Project _____

KNOW ALL MEN BY THESE PRESENTS, that we, the principal and surety above named, are held and firmly bound unto the above named contracting body, hereinafter called the contracting body, in the penal sum of the amount stated above for the payment of which sum well and truly to be made, we bind ourselves, our heirs, executors, administrators, and successors, jointly and severally, firmly by these presents.

THE CONDITION OF THIS OBLIGATION IS SUCH, that whereas the principal entered into a certain contract with the contracting body identified as shown above and hereto attached:

NOW, THEREFORE, if the principal shall promptly make payment to all persons supplying labor/material in the prosecution of the work provided for in said contract, and any and all duly authorized modifications of said contract that may hereafter be made, notice of which modifications to the surety being hereby waived, then this obligation to be void; otherwise to remain in full force and virtue.

IN WITNESS WHEREOF, the above-bounden parties have executed this instrument under their several seals on the date indicated above, the name and corporate seal of each corporate party being hereto affixed and these presents duly signed by its undersigned representative, pursuant to authority of its governing body.

Executed in _____ counterparts.

Witness:

(Proprietorship or Partnership)

Attest: (Corporation)

By: _____

Title: _____
(Corp. Sec. or Asst. Sec.. only)

(Corporate Seal)

Contractor: (Trade or Corporate Name)

By: _____

Title _____
(Owner, Partner, or Corp. Pres. or Vice Pres. only)

(Surety Company)

By: _____

Title: _____
(Attorney in Fact)

Witness:

Countersigned:

(N.C. Licensed Resident Agent)

Name and Address-Surety Agency

Surety Company Name and N.C.
Regional or Branch Office Address

(Surety Corporate Seal)

Sheet for Attaching Power of Attorney

Sheet for Attaching Insurance Certificates

APPROVAL OF THE ATTORNEY GENERAL

**CERTIFICATION BY THE OFFICE OF STATE
BUDGET AND MANAGEMENT**

Provision for the payment of money to fall due and payable by the

under this agreement has been provided for by allocation made and is available for the purpose of carrying out this agreement.

This _____ day of _____ 20____.

Signed _____
Budget Officer

Option 1 Draft

TO: All Full-Time and Part-Time Faculty
 FROM: Matthew Herrmann, Vice President for Instruction and Student Services
 DATE:
 SUBJ: COURSE ENDING DATES FOR FALL SEMESTER 2024

16 WEEK FALL SEMESTER 2024 ENDING DATES (August 15, 2024 – December 17, 2024) CLASSES WITH A FORMAL EXAM PERIOD

Fall Semester ending dates are as follows:

DAYS	Number Meeting Days AUG	Number Meeting Days SEP	Number Meeting Days OCT	Number Meeting Days NOV	Number Meeting Days DEC	Number Meeting Days Before Exam	Last Class Meeting Before Exam	Comments
M-F	12	20	21	17	8	78	W, 12/11	
MWF	7	12	12	10	5	46	W, 12/11	
MW	4	8	8	6	4	30	W, 12/11	Minutes to be added
TTH	5	8	9	7	2	31	Th, 12/5	
M-TH	9	16	17	13	7	62	W, 12/11	
MON	2	4	3	3	2	14	M, 12/9	Minutes to be added
TUE	2	4	4	4	1	15	T, 12/3	
WED	2	4	5	3	1	15	W, 12/4	
THUR	3	4	5	3	0	15	Th, 11/21	
FRI	3	4	4	4	0	15	F, 11/22	

Published Holidays

Labor Day Monday, September 2
 Fall Break Monday and Tuesday, October 14 and 15
 Veterans Day Monday, November 11
 Thanksgiving Break Wednesday, November 27
 Thanksgiving Holidays Thursday and Friday, November 28 and 29

Exam Days December 12, 13, 16, and 17
 Weather Day Wednesday, December 18

**16 WEEK FALL SEMESTER 2024 ENDING DATES
(August 15, 2024 December 17, 2024)
DAY CLASSES WITHOUT A FORMAL EXAM PERIOD**

DAYS	Number Meeting Days AUG	Number Meeting Days SEP	Number Meeting Days OCT	Number Meeting Days NOV	Number Meeting Days DEC	Number Meeting Days TOTAL	Ending Days And Dates	Comments
M-F	12	20	21	17	10	80	F, 12/13	
MWF	7	12	12	10	6	47	F, 12/13	Minutes to be added
MW	4	8	8	6	4	30	W, 12/11	Minutes to be added
TTH	5	8	9	7	3	32	T, 12/10	
M-TH	9	16	17	13	8	63	Th, 12/12	
MON	2	4	3	3	2	14	M, 12/9	Minutes to be added
TUE	2	4	4	4	2	16	T, 12/10	
WED	2	4	5	3	2	16	W, 12/11	
THUR	3	4	5	3	1	16	Th, 12/5	
FRI	3	4	4	4	1	16	F, 12/6	

EVENING CLASSES WITHOUT A FORMAL EXAM PERIOD

DAYS	Number Meeting Days AUG	Number Meeting Days SEP	Number Meeting Days OCT	Number Meeting Days NOV	Number Meeting Days DEC	Number Meeting Days TOTAL	Ending Days And Dates	Comments
M-F	12	20	21	17	10	80	F, 12/13	
MWF	7	12	12	10	7	48	M, 12/16	
MW	4	8	8	6	5	31	M, 12/16	Minutes to be added
TTH	5	8	9	7	3	32	T, 12/10	
M-TH	9	16	17	13	9	64	M, 12/16	
MON	2	4	3	3	3	15	M, 12/16	Minutes to be added
TUE	2	4	4	4	2	16	T, 12/10	
WED	2	4	5	3	2	16	W, 12/11	
THUR	3	4	5	3	1	16	Th, 12/5	
FRI	3	4	4	4	1	16	F, 12/6	

**12 WEEK FALL SEMESTER 2024 ENDING DATES
CLASSES WITH A FORMAL EXAM PERIOD
(September 13 – December 17, 2024)**

DAYS	Number Meeting Days SEP	Number Meeting Days OCT	Number Meeting Days NOV	Number Meeting Days DEC	Number Meeting Days Before Exam	Last Class Meeting Before Exam	Comments
MW	5	8	6	4	23	W, 12/11	
TTh	4	9	7	3	23	T, 12/10	
M-F	12	21	17	8	58	W, 12/11	
M-Th	9	17	13	7	46	W, 12/11	

FALL I ENDING DATES
(August 15-October 11, 2024)

DAYS	Number Meeting Days AUG	Number Meeting Days SEP	Number Meeting Days OCT	Number Meeting Days TOTAL	Ending Days And Dates	Comments
M-F	12	20	8	40	Th, 10/10	
MWF	7	12	5	24	F, 10/11	
MW	4	8	3	15	W, 10/9	Minutes to be added
TTH	5	8	3	16	T, 10/8	
M-Th	9	16	7	32	Th, 10/10	
MON	2	4	1	7	M, 10/7	Minutes to be added
TUE	2	4	2	8	T, 10/8	
WED	2	4	2	8	W, 10/9	
THUR	3	4	1	8	Th, 10/3	
FRI	3	4	1	8	F, 10/4	

FALL II ENDING DATES
(October 16 -December 17, 2024)

DAYS	Number Meeting Days OCT	Number Meeting Days NOV	Number Meeting Days DEC	Number Meeting Days TOTAL	Ending Days And Dates	Comments
M-F	12	17	11	40	M, 12/16	
MWF	7	10	7	24	M, 12/16	
MW	5	6	5	16	M, 12/16	
TTH	5	7	4	16	Th, 12/12	
M-Th	10	13	9	32	M, 12/16	
MON	2	3	3	8	M, 12/16	
TUE	2	4	2	8	T, 12/10	
WED	3	3	2	8	W, 12/11	
THUR	3	3	2	8	Th, 12/12	
FRI	2	4	2	8	F, 12/13	

Published Holidays

Labor Day Monday, September 2
 Fall Break Monday and Tuesday, October 14 and 15
 Veterans Day Monday, November 11
 Thanksgiving Break Wednesday, November 27
 Thanksgiving Holidays Thursday and Friday, November 28 and 29

 Weather Day Wednesday, December 18

CAMP LEJEUNE AND MCAS NEW RIVER
16 WEEK FALL SEMESTER 2024 ENDING DATES
 (August 15, 2024 – December 17, 2024)

DAYS	Number Meeting Days AUG	Number Meeting Days SEP	Number Meeting Days OCT	Number Meeting Days NOV	Number Meeting Days DEC	Number Meeting Days TOTAL	Ending Days And Dates	Comments
M-F	12	20	21	17	10	80	F, 12/13	
MWF	7	12	12	10	7	48	M, 12/16	
MW	4	8	8	6	5	31	M, 12/16	Minutes to be added
TTH	5	8	9	7	3	32	T, 12/10	
M-TH	9	16	17	13	9	64	M, 12/16	
MON	2	4	3	3	3	15	M, 12/16	Minutes to be added
TUE	2	4	4	4	2	16	T, 12/10	
WED	2	4	5	3	2	16	W, 12/11	
THUR	3	4	5	3	1	16	Th, 12/5	
FRI	3	4	4	4	1	16	F, 12/6	

SPRING 2025 – Option 2

TO: All Full-Time and Part-Time Faculty
 FROM: Matthew Herrmann, Vice President for Instruction and Student Services
 DATE:
 SUBJ: COURSE ENDING DATES FOR SPRING SEMESTER 2025

16 WEEK SPRING SEMESTER 2025 ENDING DATES
(January 6 – May 9, 2025)
CLASSES WITH A FORMAL EXAM PERIOD

Spring Semester ending dates are as follows:

DAYS	Number Meeting Days JAN	Number Meeting Days FEB	Number Meeting Days MAR	Number Meeting Days APR	Number Meeting Days MAY	Number Meeting Days Before Exam	Last Class Meeting Before Exam	Comments
M-F	19	19	21	16	3	78	M, 5/5	
MWF	11	11	13	9	2	46	M, 5/5	
MW	7	8	9	6	1	31	M, 5/5	
TTH	8	8	8	7	0	31	T, 4/29	
M-TH	15	16	17	13	1	62	Th, 5/1	
MON	3	4	5	2	1	15	M, 5/5	
TUE	4	4	4	3	0	15	T, 4/22	
WED	4	4	4	3	0	15	W, 4/23	
THUR	4	4	4	3	0	15	Th, 4/24	
FRI	4	3	4	3	1	15	F, 5/2	

Published Holidays: Martin Luther King, Jr. Holiday Monday, January 20
 Mid Semester Break Friday, February 28
 Spring Break Mon - Thurs, April 14-17
 Good Friday Holiday Friday, April 18
 Easter Monday Break Monday, April 21

Weather Days Mon-Tues May 12 and 13

Exam period is May 6 ,7, 8, and 9

16 WEEK SPRING SEMESTER 2025 ENDING DATES
(January 6 - May 9, 2025)
DAY CLASSES WITHOUT A FORMAL EXAM PERIOD

DAYS	Number Meeting Days JAN	Number Meeting Days FEB	Number Meeting Days MAR	Number Meeting Days APR	Number Meeting Days MAY	Number Meeting Days TOTAL	Ending Days And Dates	Comments
M-F	19	19	21	16	5	80	W, 5/7	
MWF	11	11	13	9	3	47	W, 5/7	Minutes to be added
MW	7	8	9	6	2	32	W, 5/7	
TTH	8	8	8	7	1	32	Th, 5/1	
M-TH	15	16	17	13	3	64	T, 5/6	
MON	3	4	5	2	1	15	M, 5/5	Minutes to be added
TUE	4	4	4	4	0	16	T, 4/29	
WED	4	4	4	4	0	16	W, 4/30	
THUR	4	4	4	3	1	16	Th, 5/1	
FRI	4	3	4	3	1	15	F, 5/2	Minutes to be added

EVENING CLASSES WITHOUT A FORMAL EXAM PERIOD

DAYS	Number Meeting Days JAN	Number Meeting Days FEB	Number Meeting Days MAR	Number Meeting Days APR	Number Meeting Days MAY	Number Meeting Days TOTAL	Ending Days And Dates	Comments
M-F	19	19	21	16	5	80	W, 5/7	
MWF	11	11	13	9	4	48	F, 5/9	
MW	7	8	9	6	2	32	W, 5/7	
TTH	8	8	8	7	1	32	Th, 5/1	
M-TH	15	16	17	13	3	64	T, 5/6	
MON	3	4	5	2	1	15	M, 5/5	Minutes to be added
TUE	4	4	4	4	0	16	T, 4/29	
WED	4	4	4	4	0	16	W, 4/30	
THUR	4	4	4	3	1	16	Th, 5/1	
FRI	4	3	4	3	2	16	F, 5/9	

12 WEEK SPRING SEMESTER 2025 ENDING DATES
CLASSES WITH A FORMAL EXAM PERIOD
(February 4 – May 9, 2025)

DAYS	Number Meeting Days FEB	Number Meeting Days MAR	Number Meeting Days APR	Number Meeting Days MAY	Number Meeting Days Before Exam	Last Class Meeting Before Exam	Comments
MW	7	9	6	1	23	M, 5/5	
TTh	8	8	7	0	23	T, 4/29	
M-F	18	21	16	3	58	M, 5/5	
M-Th	15	17	13	1	46	Th, 5/1	

**MAIN CAMPUS
 SPRING I ENDING DATES
 (January 6 – March 5, 2025)**

DAYS	Number Meeting Days JAN	Number Meeting Days FEB	Number Meeting Days MAR	Number Meeting Days TOTAL	Ending Days And Dates	Comments
M-F	19	19	2	40	T, 3/4	
MW	7	8	1	16	M, 3/3	
MWF	11	11	2	24	W, 3/5	
TTH	8	8	0	16	Th, 2/27	
M-Th	15	16	1	32	M, 3/3	
MON	3	4	1	8	M, 3/3	
TUE	4	4	0	8	T, 2/25	
WED	4	4	0	8	W, 2/26	
THUR	4	4	0	8	Th, 2/27	
FRI	4	3	0	7	F, 2/21	Minutes to be added

**CAMP LEJEUNE & MCAS NEW RIVER
 SPRING I ENDING DATES
 (January 6 – March 5, 2025)**

DAYS	Number Meeting Days JAN	Number Meeting Days FEB	Number Meeting Days MAR	Number Meeting Days TOTAL	Ending Days And Dates	Comments
M-F	19	18	3	40	W, 3/5	
MW	7	7	2	16	W, 3/5	
MWF	11	10	2	23	W, 3/5	Minutes to be added
TTH	8	8	0	16	Th, 2/27	
M-Th	15	15	2	32	T, 3/4	
MON	3	3	1	7	M, 3/3	Minutes to be added
TUE	4	4	0	8	T, 2/25	
WED	4	4	0	8	W, 2/26	
THUR	4	4	0	8	Th, 2/27	
FRI	4	3	0	7	F, 2/21	Minutes to be added

Classes will not meet at Camp Lejeune or Marine Corps Air Station on Monday, February 17, 2025 (President's Day).

**MAIN CAMPUS, CAMP LEJEUNE & MCAS NEW RIVER
 SPRING II ENDING DATES
 (March 6 – May 9, 2025)**

DAYS	Number Meeting Days MAR	Number Meeting Days APR	Number Meeting Days MAY	Number Meeting Days TOTAL	Ending Days And Dates	Comments
M-F	18	16	6	40	Th, 5/8	
MW	7	6	2	15	W, 5/7	Minutes to be added
MWF	11	9	4	24	F, 5/9	
TTh	7	7	2	16	T, 5/6	
M-Th	14	13	5	32	Th, 5/8	
MON	4	2	1	7	M, 5/5	Minutes to be added
TUE	3	4	1	8	T, 5/6	
WED	3	4	1	8	W, 5/7	
THUR	4	3	1	8	Th, 5/1	
FRI	4	3	1	8	F, 5/2	

**CAMP LEJEUNE AND MCAS NEW RIVER
 16 WEEK SPRING SEMESTER 2025 ENDING DATES
 (January 6 – May 9, 2025)**

DAYS	Number Meeting Days JAN	Number Meeting Days FEB	Number Meeting Days MAR	Number Meeting Days APR	Number Meeting Days MAY	Number Meeting Days TOTAL	Ending Days And Dates	Comments
M-F	19	18	21	16	6	80	Th, 5/8	
MWF	11	10	13	9	4	47	F, 5/9	Minutes to be added
MW	7	7	9	6	2	31	W, 5/7	Minutes to be added
TTH	8	8	8	7	1	32	Th, 5/1	
M-TH	15	15	17	13	4	64	W, 5/7	
MON	3	3	5	2	1	14	M, 5/5	Minutes to be added
TUE	4	4	4	4	0	16	T, 4/29	
WED	4	4	4	4	0	16	W, 4/30	
THUR	4	4	4	3	1	16	Th, 5/1	
FRI	4	3	4	3	2	16	F, 5/9	

Published Holidays: Martin Luther King, Jr. Holiday Monday, January 20
 Mid Semester Break Friday, February 28
 Spring Break Mon - Thurs, April 14-17
 Good Friday Holiday Friday, April 18
 Easter Monday Break Monday, April 21

Weather Days Mon – Tues, May 12 and 13

Classes will not meet at Camp Lejeune or Marine Corps Air Station on Monday, February 17, 2025 (President's Day).

SECTION 011000 - SUMMARY

PART 1 - GENERAL

1.1 WORK COVERED BY CONTRACT DOCUMENTS:

A. Project Identification: Project includes the following:

1. Project includes, but is not limited, to the following:

The project scope includes renovation to the first floor of the existing Learning Resources Center located on the main campus of Coastal Carolina Community College. Work involves but is not limited to selective demolition, new finishes, windows and doors, gypsum and light gauge metal framing, and new plumbing, mechanical and electrical systems. The College intends for the second floor to remain occupied and in use by the College during the course of construction.

Temporary closure shall be coordinated with the owner's representative.

2. Project Location: Jacksonville, North Carolina

3. Owner: Coastal Carolina Community College

B. Architect Identification: The Project Contract Documents, dated November 25, 2024, were prepared for Coastal Carolina Community College by Bowman Murray Hemingway Architects, PC, 514 Market Street, Wilmington, NC 28401.

C. The contract documents for this project include the following:

1. Specifications – Civil, Architectural, Structural, Plumbing, Mechanical, Electrical, Fire Alarm, and Fire Protection

2. Drawings – Civil, Architectural, Structural, Plumbing, Mechanical, Electrical, Fire Alarm, and Fire Protection

1.2 USE OF PREMISES

A. General: The Contractor shall coordinate use of the building and parking areas with the Owner's representative. Contractor staging area is delineated on sheet A1.0. The college will make special provisions for prearranged deliveries to the building to occur through parking lot P4.

B. Working Hours: Normal working hours shall be unrestricted: Work that interrupts students' needs will be stopped upon project manager(s)' request. The College's class schedule will not be modified for this project. All work must comply with the local noise ordinance. Work may not take place during the College's exam schedule. Exam dates for the Fall of 2024 and the Spring and Summer of 2025 are as follows:

Fall 2024 – December 12, 13, 16 and 17, 2024.

Spring and Summer 2025 exam schedules TBD.

The Contractor shall anticipate a total of ten (10) days for exams, including make-up dates, when no work can be performed.

- C. Site Conditions: Prior to beginning work, the Contractor shall coordinate a site walk-through with the Owner's Representative to determine the condition of sidewalks and lawn areas adjacent to the project area. Any areas damaged during construction shall be restored to original condition. This includes, but is not limited to, asphalt and concrete repairs, as well as **re-grading and seeding of lawn areas**.

1.3 PROJECT SIGN: NOT REQUIRED.

END OF SECTION 011000

SECTION 012100 - ALLOWANCES

PART 1 - GENERAL

1.1 LUMP-SUM ALLOWANCES

- A. Allowance shall include cost to Contractor of specific products and materials ordered by Owner or selected by Architect under allowance and shall include taxes, freight, and delivery to Project site.
- B. Contractor's costs for receiving and handling at Project site, labor, installation, overhead and profit, and similar costs related to products and materials ordered by Owner under allowance shall be included as part of the Contract Sum and not part of the allowance.

1.2 SCHEDULE OF ALLOWANCES

Allowance #1: Removal of 150 CY of unsuitable soils and replacement with clean sand.

END OF SECTION 012100

SECTION 012200 - UNIT PRICES

PART 1 - GENERAL

1.1 SUMMARY

- A. This Section includes administrative and procedural requirements for unit prices.
- B. See Division 1 Section "Allowances" for procedures for using unit prices to adjust quantity allowances.

1.2 DEFINITIONS

- A. Unit price is stated on the bid form as a price per unit of measurement for materials or services added to or deducted from the Contract Sum by appropriate modification, if estimated quantities of Work required by the Contract Documents are increased or decreased.

1.3 PROCEDURES

- A. Unit prices include all necessary material, plus cost for delivery, installation, insurance, applicable taxes, overhead, and profit.
- B. Measurement and Payment: Refer to individual Specification Sections for work that requires establishment of unit prices. Methods of measurement and payment for unit prices are specified in those Sections.
- C. Owner reserves the right to reject Contractor's measurement of work-in-place that involves use of established unit prices and to have this work measured, at Owner's expense, by an independent surveyor acceptable to Contractor.
- D. List of Unit Prices: A list of unit prices is included at the end of this Section. Specification Sections referenced in the schedule contain requirements for materials described under each unit price.

PART 2 - PRODUCTS (Not Used)

PART 3 - EXECUTION

LIST OF UNIT PRICES

Unit Price 1: Removal of unsuitable soils per cubic yard and replacement with compacted sand. Contractor shall provide loading and hauling to site and disposal of unsuitable soils.

\$ _____ Per CY

Unit Price 2: Removal of unsuitable soils per cubic yard and replacement with No. 57 Stone. Contractor shall provide loading and hauling to site and disposal of unsuitable soils.

\$ _____ Per CY

Unit Price 3: Removal of unsuitable soils per cubic yard and replacement with ABC stone. Contractor shall provide loading and hauling to site and disposal of unsuitable soils.

\$ _____ Per CY

END OF SECTION 012200

SECTION 012300 – ALTERNATES (SCOPE AND OWNER PREFERRED ALTERNATES)

PART 1 - GENERAL

1.1 SUMMARY

- A. This Section includes administrative and procedural requirements for alternates.

1.2 DEFINITIONS

- A. Alternate: An amount proposed by bidders and stated on the Bid Form for certain work defined in the Bidding Requirements that may be added to or deducted from the Base Bid amount if Owner decides to accept a corresponding change either in the amount of construction to be completed or in the products, materials, equipment, systems, or installation methods described in the Contract Documents.
 - 1. The cost or credit for each alternate is the net addition to or deduction from the Contract Sum to incorporate alternate into the Work. No other adjustments are made to the Contract Sum.

1.3 PROCEDURES

- A. Coordination: Modify or adjust affected adjacent work as necessary to completely integrate work of the alternate into Project.
 - 1. Include as part of each alternate, miscellaneous devices, accessory objects, and similar items incidental to or required for a complete installation whether or not indicated as part of alternate.
- B. Notification: Immediately following award of the Contract, notify each party involved, in writing, of the status of each alternate. Indicate if alternates have been accepted, rejected, or deferred for later consideration. Include a complete description of negotiated modifications to alternates.
- C. Execute accepted alternates under the same conditions as other work of the Contract.
- D. Schedule: A Schedule of Alternates is included at the end of this Section. Specification Sections referenced in schedule contain requirements for materials necessary to achieve the work described under each alternate.

PART 2 - PRODUCTS (Not Used)

PART 3 - EXECUTION

3.1 SCHEDULE OF ALTERNATES

Alternate Descriptions as well as sheet references contained in these descriptions are for reference purposes and not intended to be comprehensive. Contractors should reference the construction documents and project manual to develop a comprehensive understanding of alternate requirements and associated cost.

Project Scope Alternates:

Alternate #1: State amount to be added to the base bid to provide all labor and material to provide Covered Canopy 140. Alternate to include all architectural, structural, plumbing, mechanical and electrical work involved in construction of Covered Canopy 140 as shown on A2.0 and A3.0. Base bid to include doors 134B and sidewalks as shown on A2.1. Base bid to include infiltration trenches as delineated on civil drawings.

Alternate #2: State the amount to be added to the base bid to provide labor and material for the complete installation of a standby power system including new natural gas fueled engine-generator set, automatic transfer switch and associated conductors, conduit and equipment as shown on electrical and plumbing drawings in the construction documents.

Alternate #3: State the amount to be added to the base bid to provide labor and material for precast terrazzo treads and risers and precast terrazzo tiles as delineated at the central stair on drawing sheet A5.0 and in specific section 096623 Resinous Matrix Terrazzo Flooring. Work to include removal of metal nosing at existing stair treads. Base bid shall include sheet carpeting at central stair as specified.

Owner Preferred Brand Alternates:

Alternate #4: State the amount to be added to the base bid to provide the basis of design door hardware as specified in section 087100:

Hinges and Butts:	McKinney: TB2714/TB2314/T4B3786/T4B3386
Continuous Hinges:	Ives: 224HD
Cylinders and Keying:	Corbin Russwin
Mortise Locks:	Corbin Russwin ML2000 x LWA
Cylindrical Locks:	Corbin Russwin CL3300 Series
Door Closers:	LCN 4040XP/4040XP
Exit Devices:	Von Duprin 99 Series

Alternate #5: State the amount to be added to the base bid to provide Sliding Automatic Entrances by Stanley Automatic Sliding Doors as specified in Section 084232.

Alternate #6: State the amount to be added to the base bid to provide fire alarm systems and devices by Notifier as specified in section 283111.

Alternate #7: State the amount to be added to the base bid to provide Schneider Electric DDC system as specified in section 230923 DIRECT DIGITAL CONTROL SYSTEM FOR HVAC, drawing M7.1, and drawing M7.2.

Alternate #8: State the amount to be added to the base bid to provide telecommunication structured cabling systems and devices by Amp Netconnect as specified in section 271500.

Alternate #9: State the amount to be added to the base bid to provide the basis of design plumbing fixtures as scheduled on drawing P0.2:

1. WC-1 ADA Water Closet: American Standard 3043.001.020, Sloan 111-1.28-DFB, Bemis Manufacturing Co. 1955SSCT.
2. WC-2 Water Closet: American Standard 2234.001.020, Sloan 113-1.28-DFB-Z, Bemis Manufacturing Co. 1955SSCT.
3. UR-1 Urinal: American Standard 6590001.020, Sloan 186-0.125-DBP, Zurn Z1221-UNIV.
4. LAV-1 ADA Lavatory: American Standard 0497.221.020, Moen 8894, Jones Stephens D70100.
5. SK-1 2-Compartment Sink: Elkay LR33223, Moen 8701, Elkay LK35.
6. FD-1 Floor Drain: Sioux Chief 832-4PNR.
7. HB-1 Hose Bibb: Woodford 24P.
8. OB-1 Ice Maker Box: Sioux Chief 696-G1010XF.

Alternate #10: State the amount to be added to the base bid to provide Trane EXHG Ground-coupled heat pumps as scheduled on drawing M6.1.

Alternate #11: State the amount to be added to the base bid to provide elevator modernization to the main elevator in the Learning Resource Center Building (TKE Serial # US155244) by **TKE** as specified in section 142400.5 Hydraulic Elevator Modernization.

END OF SECTION 012300

SECTION 012500- SUBSTITUTION PRIOR TO BID

PART 1 - GENERAL

1.1 RELATED DOCUMENTS

- A. Drawings and general provisions of Contract, including General and Supplementary Conditions and other Division-1 Specification Sections, apply to this Section.
- B. This section is to be used in strict accordance with substitution criteria of Division 01 and limitations to substitution set within individual specification sections.

1.2 SUMMARY

- A. This Section specifies administrative and procedural requirements for handling requests for substitutions made prior to the receipt of bids for the project.
- B. The Contractor's Construction Schedule and the Schedule of Submittals are included under Section "Submittals."
- C. Standards: Refer to Section "Definitions and Standards" for applicability of industry standards to products specified.
- D. Procedural requirements governing the Contractor's selection of products and product options are included under Section "Product Requirements."

1.3 DEFINITIONS

- A. Definitions used in this Article are not intended to change or modify the meaning of other terms used in the Contract Documents.
- B. Products: Items purchased for incorporating into the Work, whether purchased for Project or taken from previously purchased stock. The term "product" includes the terms "material," "equipment," "system," and terms of similar intent.
 - 1. Named Products: Items identified by manufacturer's product name, including make or model number or other designation, shown or listed in manufacturer's published product literature, that is current as of date of the Contract Documents.
 - 2. New Products: Items that have not previously been incorporated into another project or facility, except that products consisting of recycled-content materials are allowed, unless explicitly stated otherwise. Products salvaged or recycled from other projects are not considered new products.

3. **Comparable Product:** Product that is demonstrated and approved through submittal process, or where indicated as a product substitution, to have the indicated qualities related to type, function, dimension, in-service performance, physical properties, appearance, and other characteristics that equal or exceed those of specified product.
- C. **Substitutions:** Requests for changes in products, materials, equipment, and methods of construction required by Contract Documents proposed by the Contractor. The following are considered substitutions:
1. Substitutions requested during bidding and accepted ten (10) days prior to the receipt of Bids for the Project.
 2. Revisions to Contract Documents requested by the Owner and/or Architect.
 3. Specified options of products and construction methods included in the Contract Documents are no longer or not readily available.
 4. Changes required due to compliance with governing regulations and orders issued by governing authorities.
- D. **Manufacturer's Warranty:** Preprinted written warranty published by individual manufacturer for a particular product and specifically endorsed by manufacturer to Owner.
- E. **Special Warranty:** Written warranty required by or incorporated into the Contract Documents, either to extend time limit provided by manufacturer's warranty or to provide more rights for Owner.

1.4 SUBMITTALS

- A. **Substitution Requests:** Submit three copies of each request for consideration a minimum of 10 days prior to bid due date. Identify product or fabrication or installation method to be replaced. Include Specification Section number and title and Drawing numbers and titles.

1.5 SUBSTITUTION REQUEST FORM: USE FORM PROVIDED AT END OF THIS SECTION.

- A. **Documentation:** Show compliance with requirements for substitutions and the following, as applicable:
1. Delete requirements below that are unnecessary or included in the Supplementary Conditions. Revise retained subparagraphs to suit Project.
 2. Statement indicating why specified material or product cannot be provided.
 3. Coordination information, including a list of changes or modifications needed to other parts of the Work and to construction performed by Owner and separate contractors, that will be necessary to accommodate proposed substitution.
 4. Detailed comparison of significant qualities of proposed substitution with those of the Work specified. Significant qualities may include attributes such as performance, weight, size, durability, visual effect, and specific features and requirements indicated.
 5. Product Data, including drawings and descriptions of products and fabrication and installation procedures.
 6. Samples, where applicable or requested.

7. List of similar installations for completed projects with project names and addresses and names and addresses of architects and owners.
8. Material test reports from a qualified testing agency indicating and interpreting test results for compliance with requirements indicated.
9. Research/evaluation reports evidencing compliance with building code in effect for Project, from a model code organization acceptable to authorities having jurisdiction.
10. Detailed comparison of Contractor's Construction Schedule using proposed substitution with products specified for the Work, including effect on the overall Contract Time. If specified product or method of construction cannot be provided within the Contract Time, include letter from manufacturer, on manufacturer's letterhead, stating lack of availability or delays in delivery.
11. Cost information, including a proposal of change, if any, in the Contract Sum.
12. Contractor's certification that proposed substitution complies with requirements in the Contract Documents and is appropriate for applications indicated.
13. Contractor's waiver of rights to additional payment or time that may subsequently become necessary because of failure of proposed substitution to produce indicated results.

- B. Architect's Action: If necessary the Architect will request additional information or documentation necessary for evaluation of the request. Upon receipt of the request, or receipt of the additional information or documentation, whichever is later, the Architect will evaluate material for acceptance or rejection of the proposed substitution. If a decision on use of a proposed substitution cannot be made or obtained within the time allocated, use the product specified by name. Acceptance of substitution request will be in the form of Addendum.

PART 2 - PRODUCTS

2.1 SUBSTITUTIONS

- A. Timing: Architect will consider requests for substitution if received a minimum of 10 days prior to the bidding of the project. Requests received after that time may be considered or rejected at the discretion of the Architect.
- B. Conditions: Architect will consider Contractor's request for substitution when the following conditions are satisfied. If the following conditions are not satisfied, Architect will return requests without action, except to record noncompliance with these requirements:
1. Requested substitution offers Owner a substantial advantage in cost, time, energy conservation, or other considerations, after deducting additional responsibilities Owner must assume. Owner's additional responsibilities may include compensation to Architect for redesign and evaluation services, increased cost of other construction by Owner, and similar considerations.
 2. Requested substitution does not require extensive revisions to the Contract Documents.
 3. Requested substitution is consistent with the Contract Documents and will produce indicated results.
 4. Substitution request is fully documented and properly submitted.
 5. Requested substitution will not adversely affect Contractor's Construction Schedule.
 6. Requested substitution has received necessary approvals of authorities having jurisdiction.

7. Requested substitution is compatible with other portions of the Work.
 8. Requested substitution has been coordinated with other portions of the Work.
 9. Requested substitution provides specified warranty.
- C. If requested substitution involves more than one contractor, requested substitution has been coordinated with other portions of the Work, is uniform and consistent, is compatible with other products, and is acceptable to all contractors involved.

PART 3 - EXECUTION (Not Applicable)

- 3.1 Refer to “Substitution Request Form” on the following page.

END OF SECTION 012500

SUBSTITUTION REQUEST FORM (Prior To Receipt Of Bids) Date: _____

Project: _____

Location: _____ Job No.: _____

To: _____

(Architect of Record)

Address: _____

SPECIFIED PRODUCT OR SYSTEM:

Section: _____ Name: _____

Description: _____

SUBSTITUTE PRODUCT OR SYSTEM:

Section: _____ Name: _____

Description: _____

SUBSTITUTION ANALYSIS:

Reason for substitution request: _____

Substitution affects other materials or systems: YES ___ NO _____ If YES, attach complete data.

The following data is furnished herewith for evaluation of the substitution:

_____ Catalog _____ Drawings _____ Samples _____ Test Reports

Other: _____

THE UNDERSIGNED HEREBY CERTIFIES THAT THIS SUBMITTAL HAS BEEN FULLY CHECKED AND COORDINATED WITH THE CONTRACT DOCUMENTS.

From: _____

Address: _____

Phone: _____ Fax: _____

Signed: _____

SECTION 012600 - CONTRACT MODIFICATION PROCEDURES

PART 1 - GENERAL

1.1 SUMMARY

- A. This Section specifies administrative and procedural requirements for handling and processing Contract modifications.

1.2 MINOR CHANGES IN THE WORK

- A. Architect will issue supplemental instructions authorizing Minor Changes in the Work, not involving adjustment to the Contract Sum or the Contract Time, on Architect's Supplemental Instructions.

1.3 PROPOSAL REQUESTS

- A. Owner-Initiated Proposal Requests: Architect will issue a detailed description of proposed changes in the Work that may require adjustment to the Contract Sum or the Contract Time. If necessary, the description will include supplemental or revised Drawings and Specifications.
 - 1. Proposal Requests issued by Architect are for information only. Do not consider them instructions either to stop work in progress or to execute the proposed change.
 - 2. Within 5 days after receipt of Proposal Request, submit a quotation estimating cost adjustments to the Contract Sum and the Contract Time necessary to execute the change.
 - a. Include a list of quantities of products required or eliminated and unit costs, with total amount of purchases and credits to be made. If requested, furnish survey data to substantiate quantities.
 - b. Indicate applicable taxes, delivery charges, equipment rental, and amounts of trade discounts.
 - c. Include requests for an extension of contract time, if required, in the proposal.
- B. Contractor-Initiated Proposals: If latent or unforeseen conditions require modifications to the Contract, Contractor may propose changes by submitting a request for a change.
 - 1. Include a statement outlining reasons for the change and the effect of the change on the Work. Provide a complete description of the proposed change. Indicate the effect of the proposed change on the Contract Sum and the Contract Time.
 - 2. Include a list of quantities of products required or eliminated and unit costs, with total amount of purchases and credits to be made. If requested, furnish survey data to substantiate quantities.

3. Indicate applicable taxes, delivery charges, equipment rental, and amounts of trade discounts.

END OF SECTION 012600

SECTION 012900 - PAYMENT PROCEDURES

PART 1 - GENERAL

1.1 SUMMARY

- A. This Section specifies administrative and procedural requirements necessary to prepare and process Applications for Payment.

1.2 SCHEDULE OF VALUES

- A. Coordination: Coordinate preparation of the Schedule of Values (AIA G-702 & 703) with preparation of Contractor's Construction Schedule.

- 1. Correlate line items in the Schedule of Values with other required administrative forms and schedules, including Application for Payment forms with Continuation Sheets.
- 2. Submit the Schedule of Values to Architect at earliest possible date but no later than seven days before the date scheduled for submittal of initial Applications for Payment.
- 3. Subschedules: Where the Work is separated into phases requiring separately phased payments, provide subschedules showing values correlated with each phase of payment.

- B. Format and Content: Use the Project Manual table of contents as a guide to establish line items for the Schedule of Values. Provide at least one line item for each Specification Section.

- 1. Identification: Include the following Project identification on the Schedule of Values:

- a. Project name and location.
- b. Name of Architect.
- c. Architect's project number.
- d. Contractor's name and address.
- e. Date of submittal.

- 2. Arrange the Schedule of Values in tabular form with separate columns to indicate the following for each item listed:

- a. Related Specification Section.
- b. Description of the Work – broken down into material and labor.
- c. Change Orders (numbers) that affect value.
- d. Dollar value:

- 1. Percentage of the Contract Sum to nearest one-hundredth percent, adjusted to total 100 percent.

3. Provide a breakdown of the Contract Sum in enough detail to facilitate continued evaluation of Applications for Payment and progress reports. Coordinate with the Project Manual table of contents. Provide several line items for principal subcontract amounts, where appropriate.
4. Round amounts to nearest whole dollar; total shall equal the Contract Sum.
5. Provide a separate line item in the Schedule of Values for each part of the Work where Applications for Payment may include materials or equipment purchased or fabricated and stored, but not yet installed.
6. Provide separate line items in the Schedule of Values for initial cost of materials and labor, for each subsequent stage of completion, and for total installed value of that part of the Work. Submit sample to architect for approval.
7. Each item in the Schedule of Values and Applications for Payment shall be complete. Include total cost and proportionate share of general overhead and profit for each item.
 - a. Temporary facilities and other major cost items that are not direct cost of actual work-in-place may be shown either as separate line items in the Schedule of Values or distributed as general overhead expense, at Contractor's option.
8. Schedule Updating: Update and resubmit the Schedule of Values before the next Applications for Payment when Change Orders or Construction Change Directives result in a change in the Contract Sum.

1.3 APPLICATIONS FOR PAYMENT

- A. Each Application for Payment shall be consistent with previous applications and payments as certified by Architect and paid for by Owner.
 1. Initial Application for Payment and final Application for Payment involve additional requirements.
- B. Payment Application Times: The date for each progress payment is indicated in the Agreement between Owner and Contractor. The period of construction Work covered by each Application for Payment is 30 days.
- C. Payment Application Times: The date for each progress payment application is no later than the fifth day of the month. The period covered by each Application for Payment starts on the day following the end of the preceding period and ends 30 days afterwards.
- D. On Owner's approval of a Proposal Request, Architect will issue a Change Order for signatures of Agency, Owner and Contractor on Change Order Form.
- E. Application Preparation: Complete every entry on form. Notarize and execute by a person authorized to sign legal documents on behalf of Contractor. Architect will return incomplete applications without action.
 1. Entries shall match data on the Schedule of Values and Contractor's Construction Schedule. Use updated schedules if revisions were made.

2. Include amounts of Change Orders and Construction Change Directives issued before last day of construction period covered by application.
- F. **Retainage:** Payment will be made on the basis of 95% of monthly estimates and final payment made upon completion and acceptance of the work. Retainage will not exceed 5% at any time.
- G. **Transmittal:** Submit 5 signed and notarized original copies of each Application for Payment to Architect by a method ensuring receipt. One copy shall include waivers of lien and similar attachments if required. At the option of the owner's representative, Pay Application may be made electronically.
1. Transmit each copy with a transmittal form listing attachments and recording appropriate information about application.
- H. **Initial Application for Payment:** Administrative actions and submittals that must precede or coincide with submittal of first Application for Payment include the following:
1. List of subcontractors.
 2. Schedule of Values.
 3. Contractor's Construction Schedule (preliminary if not final).
 4. Submittals Schedule (preliminary if not final).
 5. List of Contractor's staff assignments.
 6. Copies of building permits.
 7. Copies of authorizations and licenses from authorities having jurisdiction for performance of the Work.
 8. Certificates of insurance and insurance policies.
 9. Performance and payment bonds.
- I. **Final Payment Application:** Submit final Application for Payment with releases and supporting documentation not previously submitted and accepted, including, but not limited, to the following:
1. Evidence of completion of Project closeout requirements.
 2. Updated final statement, accounting for final changes to the Contract Sum.
 3. Final meter readings for utilities, a measured record of stored fuel, and similar data as of date of Final Acceptance or when Owner took possession of and assumed responsibility for corresponding elements of the Work.

1.4 DOCUMENTS REQUIRED FOR CLOSE OUT OF PROJECTS

Unless specifically noted, FOUR copies of all required.

A. WARRANTIES AND GUARANTEES REQUIRED BY THE CONTRACT

1. **General Contract:**
 - a. Contractor's warranty letter guaranteeing their work for a period of one year from the date of final inspection.
 - b. Contractor's Affidavit of Payment of Debts and Claims

- c. Contractor's Affidavit of Release of Liens
- d. Consent of Surety to final payment.
- e. Warranties required by other sections within the Project Manual.
- f. Record of Owner training including video record of HVAC training.
- g. Proof of transfer of attic stock to Owner.
- h. Plumbing Contract:
 - 1. Contractor's warranty letter guaranteeing their work for a period of one year from the date of acceptance by the Owner.
 - 2. Manufacturer's warranties for specific plumbing equipment. (Include in plumbing O&M manual.)
 - 3. Certification of Disinfection of Domestic Water Piping System.
- i. Mechanical Contract:
 - 1. Contractor's warranty letter guaranteeing their work for a period of one year from the date of acceptance by the Owner.
 - 2. Manufacturer's warranties for specific mechanical equipment. (Include in mechanical O&M manual.)
- j. Electrical Contract
 - 1. Contractor's warranty letter guaranteeing their work for a period of one year from the date of acceptance by the Owner.
 - 2. Manufacturer's warranties for specific electrical equipment. (Include in electrical O&M manual.)

B. CERTIFICATES OF AGENCIES REQUIRED BY STATE LAW

- 1. SCO electrical inspection (certificate of electrical completion).
- 2. Fire alarm systems record of completion (certification) as required by NFPA 72.

C. LIST OF SUBCONTRACTORS / MATERIAL SUPPLIERS, ETC.

- 1. A listing (which includes names, addresses and phone numbers) of subcontractors and material suppliers involved from Prime through second tier subcontractors and the area of construction in which they did work.

D. OPERATION & MAINTENANCE MANUALS (2 copies)

- 1. Bound volume(s) with tabs to include operations and maintenance manuals for each piece of equipment provided under the contract. Manuals should be separate for plumbing, mechanical and electrical work. Operations and maintenance data shall include operation, maintenance, and inspection data, replacement part numbers and availability, and service depot location and telephone numbers of suppliers.

Manufacturers' warranty and any other application forms have been completed in Owner's name and registered with the manufacturer prior to being included in the O&M manual.

E. AS-BUILT DRAWINGS (one copy required) (SEE SECTION 017700 CLOSEOUT PROCEDURES).

F. ITEMS A, B, AND C TO BE BOUND AND INDEXED IN A TITLED BINDER.

END OF SECTION 012900

SECTION 013100 - PROJECT MANAGEMENT AND COORDINATION

PART 1 - GENERAL

1.1 SUMMARY

- A. This Section includes administrative provisions for coordinating construction operations on Project including, but not limited to, the following:
1. General Project coordination procedures.
 2. Coordination Drawings.
 3. Project meetings.

1.2 COORDINATION

- A. Coordination: Coordinate construction operations included in various Sections of the Specifications to ensure efficient and orderly installation of each part of the Work. Coordinate construction operations, included in different Sections, that depend on each other for proper installation, connection, and operation.
1. Schedule construction operations in sequence required to obtain the best results where installation of one part of the Work depends on installation of other components, before or after its own installation.
 2. Coordinate installation of different components with other contractors to ensure maximum accessibility for required maintenance, service, and repair.
 3. Make adequate provisions to accommodate items scheduled for later installation.

1.3 PROJECT MEETINGS

- A. General: The Architect will schedule and conduct meetings and conferences at Project site.
1. Attendees: Inform participants and others involved, and individuals whose presence is required, of date and time of each meeting. Meeting dates and times will be scheduled at the Preconstruction Conference.
 2. Agenda: Prepare the meeting agenda. Distribute the agenda to all invited attendees.
 3. Designer records and distributes the final monthly progress meeting minutes to Owner and Contractor.
- B. Preconstruction Conference: The Architect will schedule a preconstruction conference before starting construction, at a time convenient to Owner and General Contractor, but no later than 15 days after execution of the Agreement. Hold the conference at Project site or another convenient location. Conduct the meeting to review responsibilities and personnel assignments.
1. Attendees: Authorized representatives of Owner, Architect, and their consultants; representative of the Office of State Construction; Contractor and its

superintendent; major subcontractors; manufacturers; suppliers; and other concerned parties shall attend the conference. All participants at the conference shall be familiar with Project and authorized to conclude matters relating to the Work.

2. Agenda: Discuss items of significance that could affect progress, including the following:

- a. Tentative construction schedule.
- b. Phasing.
- c. Critical work sequencing.
- d. Designation of responsible personnel.
- e. Procedures for processing field decisions and Change Orders.
- f. Procedures for processing Applications for Payment.
- g. Distribution of the Contract Documents.
- h. Submittal procedures.
- i. Preparation of Record Documents.
- j. Use of the premises.
- k. Responsibility for temporary facilities and controls.
- l. Parking availability.
- m. Office, work, and storage areas.
- n. Equipment deliveries and priorities.
- o. First aid.
- p. Security.
- q. Progress cleaning.
- r. Working hours.

C. The Architect will schedule Progress Meetings: Conduct progress meetings at monthly intervals. Coordinate dates of meetings with preparation of payment requests.

1. Attendees: In addition to representatives of Owner and Architect, representative of the Office of State Construction, each contractor, subcontractor, supplier, and other entity concerned with current progress or involved in planning, coordination, or performance of future activities shall be represented at these meetings. All participants at the conference shall be familiar with Project and authorized to conclude matters relating to the Work.

2. Agenda: Review and correct or approve minutes of previous progress meeting. Review other items of significance that could affect progress. Include topics for discussion as appropriate to status of Project.

a. Contractor's Construction Schedule: Review progress since the last meeting. Determine whether each activity is on time, ahead of schedule, or behind schedule, in relation to Contractor's Construction Schedule. Determine how construction behind schedule will be expedited; secure commitments from parties involved to do so. Discuss whether schedule revisions are required to ensure that current and subsequent activities will be completed within the Contract Time.

b. Review present and future needs of each entity present, including the following:

- 1) Interface requirements.
- 2) Sequence of operations.

- 3) Status of submittals.
 - 4) Deliveries.
 - 5) Off-site fabrication.
 - 6) Access.
 - 7) Site utilization.
 - 8) Temporary facilities and controls.
 - 9) Work hours.
 - 10) Hazards and risks.
 - 11) Progress cleaning.
 - 12) Quality and work standards.
 - 13) Change Orders.
 - 14) Documentation of information for payment requests.
3. Reporting: Distribute minutes of the meeting to each party present and to parties who should have been present. Include a brief summary, in narrative form, that includes the following information:
- a. Review previous minutes of the meeting and resolve any corrections.
 - b. Work performed in the last 30 days.
 - c. Work to be performed in the next 30 days.
 - d. Request for Proposal.
 - e. Review Pending Change Orders.
 - f. Review Request for Information.
 - g. Review Status of Shop Drawings.
 - h. Review Schedule Compliance.
 - i. Percentages Complete to be reported by the Contractor(s) – (Actual Work Completed)
 - j. Discuss Construction/Coordination Issues.
 - k. Designer Weekly Inspection Reports – Non-Conforming Work
 - l. Special Inspection Reports – Deficiency Notices
 - m. Comments from Owner, State Construction Office, Contractor(s), and Designers.

END OF SECTION 013100

SECTION 013200 - CONSTRUCTION PROGRESS DOCUMENTATION

PART 1 - GENERAL

1.1 SUMMARY

- A. This Section includes administrative and procedural requirements for documenting the progress of construction during performance of the Work, including the following:
 - 1. Submittals Schedule.
 - 2. See Division 1 Section "Project Management and Coordination" for Project Schedules and Reporting.

- B. See Division 1 Section "Payment Procedures" for submitting the Schedule of Values.

1.2 SUBMITTALS

- A. Submittals Schedule: Submit three copies of schedule. Arrange the following information in a tabular format:
 - 1. Scheduled date for first submittal.
 - 2. Specification Section number and title.
 - 3. Submittal category (action or informational).
 - 4. Name of subcontractor.
 - 5. Description of the Work covered.
 - 6. Scheduled date for Architect's final release or approval.

PART 2 - PRODUCTS

2.1 SUBMITTALS SCHEDULE

- A. Preparation: Submit a schedule of submittals, arranged in chronological order by dates required by construction schedule. Include time required for review, resubmittal, ordering, manufacturing, fabrication, and delivery when establishing dates.
 - 1. Coordinate Submittals Schedule with list of subcontracts, the Schedule of Values, and Contractor's Construction Schedule.
 - 2. Submit concurrently with the first complete submittal of Contractor's Construction Schedule.

END OF SECTION 013200

SECTION 013300 - SUBMITTAL PROCEDURES

PART 1 - GENERAL

1.1 SUMMARY

- A. This Section includes administrative and procedural requirements for submitting Shop Drawings, Product Data, Samples, and other miscellaneous submittals.
- B. See Division 1 Section "Construction Progress Documentation" for submitting schedules and reports, including Contractor's Construction Schedule and the Submittals Schedule.
- C. See Division 1 Section "Closeout Procedures" for submitting warranties Project Record Documents and operation and maintenance manuals.

1.2 DEFINITIONS

- A. Action Submittals: Written and graphic information that requires Architect's responsive action.
- B. Informational Submittals: Written information that does not require Architect's approval. Submittals may be rejected for not complying with requirements.

1.3 SUBMITTAL PROCEDURES

- A. Coordination: Coordinate preparation and processing of submittals with performance of construction activities.
 - 1. Coordinate each submittal with fabrication, purchasing, testing, delivery, other submittals, and related activities that require sequential activity.
 - 2. Coordinate transmittal of different types of submittals for related parts of the Work so processing will not be delayed because of need to review submittals concurrently for coordination.
 - a. Architect reserves the right to withhold action on a submittal requiring coordination with other submittals until related submittals are received.
- B. Submittals Schedule: Comply with requirements in Division 1 Section "Construction Progress Documentation" for list of submittals and time requirements for scheduled performance of related construction activities.
- C. Processing Time: Allow enough time for submittal review, including time for resubmittals, as follows. Time for review shall commence on Architect's receipt of submittal.
 - 1. Initial Review: Allow 15 days for initial review of each submittal. Allow additional time if processing must be delayed to permit coordination with

- subsequent submittals. Architect will advise Contractor when a submittal being processed must be delayed for coordination.
2. If intermediate submittal is necessary, process it in same manner as initial submittal.
 3. Allow 15 days for processing each resubmittal.
 4. No extension of the Contract Time will be authorized because of failure to transmit submittals enough in advance of the Work to permit processing.
- D. Identification: Place a permanent label or title block on each submittal for identification.
1. Indicate name of firm or entity that prepared each submittal on label or title block.
 2. Provide a space approximately 4 by 5 inches on label or beside title block to record Contractor's review and approval markings and action taken by Architect.
 3. Include the following information on label for processing and recording action taken:
 - a. Project name.
 - b. Date.
 - c. Name and address of Prime Contractor.
 - d. Name, phone number and address of subcontractor or supplier.
 - e. Unique identifier, including revision number.
- E. Deviations: Highlight, encircle, or otherwise identify deviations from the Contract Documents on submittals.
- F. Additional Copies: Unless additional copies are required for final submittal, and unless Architect observes noncompliance with provisions of the Contract Documents, initial submittal may serve as final submittal.
- G. Transmittal: Package each submittal individually and appropriately for transmittal and handling. Transmit each submittal using a transmittal form. Architect will return submittals received from sources other than Contractor.
- H. Distribution: Furnish copies of final submittals to manufacturers, subcontractors, suppliers, fabricators, installers, authorities having jurisdiction, and others as necessary for performance of construction activities. Show distribution on transmittal forms.
- I. Use for Construction: Use only final submittals with mark indicating action taken by Architect in connection with construction.

PART 2 - PRODUCTS

2.1 ACTION SUBMITTALS

- A. General: Prepare and submit Action Submittals required by individual Specification Sections.
1. Number of Copies: Submit six (6) copies of each submittal, unless otherwise indicated. Architect will return five (5) or if it is an engineer's review they will

return four (4) copies. Mark up and retain one returned copy as a Project Record Document.

- B. Product Data: Collect information into a single submittal for each element of construction and type of product or equipment.
1. If information must be specially prepared for submittal because standard printed data are not suitable for use, submit as Shop Drawings, not as Product Data.
 2. Mark each copy of each submittal to show which products and options are applicable.
 3. Include the following information, as applicable:
 - a. Manufacturer's written recommendations.
 - b. Manufacturer's product specifications.
 - c. Manufacturer's installation instructions.
 - d. Manufacturer's catalog cuts.
 - e. Wiring diagrams showing factory-installed wiring.
 - f. Printed performance curves.
 - g. Operational range diagrams.
 - h. Compliance with recognized trade association standards.
 - i. Compliance with recognized testing agency standards.
- C. Shop Drawings: Prepare Project-specific information, drawn accurately to scale. Do not base Shop Drawings on reproductions of the Contract Documents or standard printed data.
1. Preparation: Include the following information, as applicable:
 - a. Dimensions.
 - b. Identification of products.
 - c. Fabrication and installation drawings.
 - d. Roughing-in and setting diagrams.
 - e. Wiring diagrams showing field-installed wiring, including power, signal, and control wiring.
 - f. Shopwork manufacturing instructions.
 - g. Templates and patterns.
 - h. Schedules.
 - i. Notation of coordination requirements.
 - j. Notation of dimensions established by field measurement.
 2. Wiring Diagrams: Differentiate between manufacturer-installed and field-installed wiring.
 3. Sheet Size: Except for templates, patterns, and similar full-size drawings, submit Shop Drawings on sheets at least 8-1/2 by 11 inches but no larger than 30 by 40 inches.
- D. Samples: Prepare physical units of materials or products, including the following:
1. Samples for Initial Selection: Submit manufacturer's color charts consisting of units or sections of units showing the full range of colors, textures, and patterns available.

- a. Submit three full sets of available choices where color, pattern, texture, or similar characteristics are required to be selected from manufacturer's product line. Architect will return submittal with options selected.
 2. Samples for Verification: Submit full-size units or Samples of size indicated, prepared from the same material to be used for the Work, cured and finished in manner specified, and physically identical with the product proposed for use, and that show full range of color and texture variations expected. Samples include, but are not limited to, partial sections of manufactured or fabricated components; small cuts or containers of materials; complete units of repetitively used materials; swatches showing color, texture, and pattern; color range sets; and components used for independent testing and inspection.
 - a. Submit three sets of Samples. Architect will retain two Sample sets; remainder will be returned.
 3. Preparation: Mount, display, or package Samples in manner specified to facilitate review of qualities indicated. Prepare Samples to match Architect's sample where so indicated. Attach label on unexposed side.
 4. Submit Samples for review of kind, color, pattern, and texture for a final check of these characteristics with other elements and for a comparison of these characteristics between final submittal and actual component as delivered and installed.
 5. Disposition: Maintain sets of approved Samples at Project site, available for quality-control comparisons throughout the course of construction activity. Sample sets may be used to determine final acceptance of construction associated with each set.
- E. Submittals Schedule: Comply with requirements in Division 1 Section "Construction Progress Documentation."
- F. Application for Payment: Comply with requirements in Division 1 Section "Payment Procedures."
- G. Schedule of Values: Comply with requirements in Division 1 Section "Payment Procedures."

PART 3 - EXECUTION

3.1 CONTRACTOR'S REVIEW

- A. Review each submittal and check for compliance with the Contract Documents. Note corrections and field dimensions. Mark with approval stamp before submitting to Architect.
- B. Approval Stamp: Stamp each submittal with a uniform, approval stamp. Include Project name and location, submittal number, Specification Section title and number, name of reviewer, date of Contractor's approval, and statement certifying that submittal has been reviewed, checked, and approved for compliance with the Contract Documents.

3.2 ARCHITECT'S ACTION

- A. General: Architect will not review submittals that do not bear Contractor's approval stamp and will return them without action.
- B. Action Submittals: Architect will review each submittal, make marks to indicate corrections or modifications required, and return it. Architect will stamp each submittal with an action stamp and will mark stamp appropriately to indicate action taken, as follows:
 - 1. Approved.
 - 2. Rejected/Resubmit.
 - 3. Approved as noted.

END OF SECTION 013300

SECTION 014000 - QUALITY ASSURANCE AND TESTING REQUIREMENTS

PART 1 - GENERAL

1.1 SUMMARY

- A. This Section includes administrative and procedural requirements for quality assurance.

1.2 DEFINITIONS

- A. Quality-Assurance Services: Activities, actions, and procedures performed before and during execution of the Work to guard against defects and deficiencies and ensure that proposed construction complies with requirements.
- B. Quality-Control Services: Tests, inspections, procedures, and related actions during and after execution of the Work to evaluate that completed construction complies with requirements. Services do not include contract enforcement activities performed by Architect.
- C. Mockups: Full-size, physical example assemblies to illustrate finishes and materials. Mockups are used to verify selections made under Sample submittals, to demonstrate aesthetic effects and, where indicated, qualities of materials and execution, and to review construction, coordination, testing, or operation; they are not Samples
- D. Testing Agency: An entity engaged to perform specific tests, inspections, or both. Testing laboratory shall mean the same as testing agency.

1.3 DELEGATED DESIGN

- A. Performance and Design Criteria: Where professional design services or certifications by a design professional are specifically required of Contractor by the Contract Documents, provide products and systems complying with specific performance and design criteria indicated. If criteria indicated are not sufficient to perform services or certification required, submit a written request for additional information to Architect.

1.4 SUBMITTALS

- A. Qualification Data: For testing agencies specified in "Quality Assurance" Article to demonstrate their capabilities and experience. Include proof of qualifications in the form of a recent report on the inspection of the testing agency by a recognized authority.
- B. Delegated-Design Submittal: In addition to Shop Drawings, Product Data, and other required submittals, submit a statement, signed and sealed by the responsible design professional licensed to practice in the State of North Carolina, for each product and system specifically assigned to Contractor to be designed or certified by a design professional, indicating that the products and systems are in compliance with performance and design criteria indicated. Include list of codes, loads, and other factors used in performing these services.

C. Testing Schedule.

1. During the preconstruction conference, the contractor shall meet with the architect and testing services to review the specific testing requirements for the project. Within seven days of the preconstruction meeting, the contractor shall submit a testing schedule identifying the scope of work of owner and contractor provided testing companies and anticipated testing periods.

D. Contractor Provided Testing Reports

1. Reports: Prepare and submit certified written reports that include the following:
 - a. Date of issue.
 - b. Project title and number.
 - c. Name, address, and telephone number of testing agency.
 - d. Dates and locations of samples and tests or inspections.
 - e. Names of individuals making tests and inspections.
 - f. Description of the Work and test and inspection method.
 - g. Identification of product and Specification Section.
 - h. Complete test or inspection data.
 - i. Test and inspection results and an interpretation of test results.
 - j. Ambient conditions at time of sample taking and testing and inspecting.
 - k. Comments or professional opinion on whether tested or inspected Work complies with the Contract Document requirements.
 - l. Name and signature of laboratory inspector.
 - m. Recommendations on retesting and reinspecting.

1.5 TESTING

A. Testing responsibilities shall be assigned on the following basis:

- | | |
|------------------------|-------------------------|
| 1. Soil Testing | Owner Provided and Paid |
| 2. Concrete Testing | Owner Provided and Paid |
| 3. Steel Testing | Owner Provided and Paid |
| 4. Special Inspections | Owner Provided and Paid |

1.6 OWNER PROVIDED TESTING

A. Owner Responsibilities: Where quality-control services are indicated as Owner's responsibility, Owner will engage a qualified testing agency to perform these services.

1. Owner will furnish Contractor with names, addresses, and telephone numbers of testing agencies engaged and a description of the types of testing and inspecting they are engaged to perform.
2. Costs for retesting and reinspecting construction that replaces or is necessitated by work that failed to comply with the Contract Documents will be charged to Contractor.

B. Contractor Responsibilities:

1. Notify testing agencies at least 24 hours in advance of time when Work that requires testing or inspecting will be performed.
2. Testing and inspecting requested by Contractor and not required by the Contract Documents are Contractor's responsibility.

1.7 CONTRACTOR ASSOCIATED SERVICES:

- A. Cooperate with agencies performing required tests, inspections, and similar quality-control services, and provide reasonable auxiliary services as requested. Notify agency sufficiently in advance of operations to permit assignment of personnel. Provide the following:
 1. Access to the Work.
 2. Incidental labor and facilities necessary to facilitate tests and inspections.
 3. Adequate quantities of representative samples of materials that require testing and inspecting. Assist agency in obtaining samples.
 4. Facilities for storage and field-curing of test samples.
 5. Preliminary design mix proposed for use for material mixes that require control by testing agency.
 6. Security and protection for samples and for testing and inspecting equipment at Project site.
- B. Coordination: Coordinate sequence of activities to accommodate required quality-assurance and quality-control services with a minimum of delay and to avoid necessity of removing and replacing construction to accommodate testing and inspecting.

PART 2 - PRODUCTS (Not Used)

PART 3 - EXECUTION

3.1 REPAIR AND PROTECTION

- A. General: On completion of testing, inspecting, sample taking, and similar services, repair damaged construction and restore substrates and finishes.
 1. Provide materials and comply with installation requirements specified in other Sections of these Specifications. Restore patched areas and extend restoration into adjoining areas in a manner that eliminates evidence of patching.
 2. Comply with the Contract Document requirements for Division 1 Section "Cutting and Patching."
- B. Protect construction exposed by or for quality-control service activities.
- C. Repair and protection are Contractor's responsibility, regardless of the assignment of responsibility for quality-control services.

END OF SECTION 014000

SECTION 014200 - REFERENCES

PART 1 - GENERAL

1.1 INDUSTRY STANDARDS

- A. Applicability of Standards: Unless the Contract Documents include more stringent requirements, applicable construction industry standards have the same force and effect as if bound or copied directly into the Contract Documents to the extent referenced. Such standards are made a part of the Contract Documents by reference.
- B. Publication Dates: Comply with standards in effect as of date of the Contract Documents, unless otherwise indicated.
- C. Conflicting Requirements: If compliance with two or more standards is specified and the standards establish different or conflicting requirements for minimum quantities or quality levels, comply with the most stringent requirement. Refer uncertainties and requirements that are different, but apparently equal, to Architect for a decision before proceeding.
 - 1. Minimum Quantity or Quality Levels: The quantity or quality level shown or specified shall be the minimum provided or performed. The actual installation may comply exactly with the minimum quantity or quality specified, or it may exceed the minimum within reasonable limits. To comply with these requirements, indicated numeric values are minimum or maximum, as appropriate, for the context of requirements. Refer uncertainties to Architect for a decision before proceeding.
- D. Industry Organizations: Where abbreviations and acronyms are used in Specifications or other Contract Documents, they shall mean the recognized name of the entities indicated in Gale Research's "Encyclopedia of Associations" or in Columbia Books' "National Trade & Professional Associations of the U.S."

END OF SECTION 014200

SECTION 014533 - SPECIAL INSPECTIONS – SEAL SHEET



Divisions, 1 – Section 014533 – Special Inspections
Structural Engineer
Adam Sisk, PE, SE
Woods Engineering, PA
254 N Front St. Suite 201
Wilmington, NC 28401
(910) 343-8007

SECTION 014533 - SPECIAL INSPECTIONS

PART 1 GENERAL

1.1 RELATED DOCUMENTS

- A. Drawings and general provisions of the Contract, including General and Supplementary General Conditions and other Division I Specification Sections, apply to this Section.

1.2 GENERAL REQUIREMENTS

- A. Special Inspections and Structural Testing shall be in accordance with Chapter 17 of the North Carolina Building Code.
- B. The program of Special Inspection and Structural Testing is a Quality Assurance program intended to ensure that the work is performed in accordance with the Contract Documents
- C. This specification section is intended to inform the Contractor of the Owner's quality assurance program and the extent of the Contractor's responsibilities. This specification section is also intended to notify the Special Inspector, Testing Company/Testing Laboratory, and other Agents of the Special Inspector of their requirements and responsibilities.

1.3 SCHEDULE OF INSPECTIONS AND TESTS

- A. Required inspections and tests are described in the attached Schedule of Special Inspections and in the individual Specification Sections for the items to be inspected or tested.

1.4 QUALIFICATIONS

- A. The Special Inspector shall be a licensed Professional Engineer who is approved by the Structural Engineer of Record (SER) and Building Official.
- B. The Testing Company/Testing Laboratory and individual technicians shall be approved by the Structural Engineer of Record (SER) and Building Official.
- C. The Testing Company/Testing Laboratory shall retain a full-time licensed Professional Engineer on staff who shall certify all test reports. The Engineer shall be responsible for the training of the testing technicians and shall be in responsible charge of the field and laboratory testing operations.
 - 1. Special Inspections of soils and foundations may be performed by inspectors with an education and background in geotechnical engineering in lieu of a background in structural engineering.
 - 2. Technicians performing sampling and testing of concrete shall be ACI certified Concrete Field Testing Technicians-Grade 1.
 - 3. Inspectors performing inspections of concrete work such as inspections of concrete placement, batching, reinforcing placement, curing and protection, may be ACI certified Concrete Construction Inspectors or ICBO certified Reinforced Concrete Special Inspector in lieu of being a licensed P.E. or EIT.

4. Inspectors performing inspections of prestressed concrete work may be ICBO/BOCA/SBCCI certified Prestressed Concrete Special Inspector.
5. Inspectors performing inspections of masonry may be ICBO certified Structural Masonry Special Inspector.
6. Technicians performing visual inspection of welding shall be AWS Certified Welding Inspectors or ICBO certified Structural Steel and Welding Special Inspectors, technicians performing non-destructive testing such as ultrasonic testing, radiographic testing, magnetic particle testing, or dye-penetrant testing shall be certified as an ASNT-TC Level II or Level III technician.
7. Inspectors performing inspections of spray fireproofing may be ICBO certified Spray-Applied Fireproofing Special Inspector.
8. Technicians performing standard tests described by specific ASTM Standards shall have training in the performance of such tests and must be able to demonstrate either by oral or written examination competence for the test to be conducted. They shall be under the supervision of a licensed Professional Engineer and shall not be permitted to independently evaluate test results.

1.5 SUBMITTALS

- A. The Special Inspector and Testing Company/Testing Laboratory shall submit to the SER and Building Official for review a copy of their qualifications which shall include the names and qualifications of each of the individual inspectors and technicians who will be performing inspections or tests.
- B. The Special Inspector and Testing Company/Testing Laboratory shall disclose any past or present business relationship or potential conflict of interest with the Contractor or any of the Subcontractors whose work will be inspected or tested.

1.6 PAYMENT

- A. The Owner shall engage and pay for the services of the Special Inspector, Agents of the Special Inspector or Testing Company/Testing Laboratory.
- B. If any materials which require Special Inspections are fabricated in a plant which is not located within 150 miles of the project, the Contractor shall be responsible for the travel expenses of the Special Inspector of Testing Company/Testing Laboratory.
- C. The Contractor shall be responsible for the cost of any retesting or reinspection of work which fails to comply with the requirements of the Contract Documents.

1.7 CONTRACTOR RESPONSIBILITIES

- A. The Contractor shall cooperate with the Special Inspector and his agents so that the Special Inspections and testing may be performed without hindrance.
- B. The Contractor shall review the Statement of Special Inspections and shall be responsible for coordinating and scheduling inspections and tests. The Contractor shall notify the Structural Engineer of Record, Special Inspector or Testing Company/Testing Laboratory at least 48 hours in advance of a required inspection or test. Uninspected work that required inspection may be rejected solely on that basis.

- C. The Contractor shall complete the attached Contractor Statement of Responsibility and submit to owner with the signed contracts.
- D. The Contractor shall provide the form for the Final Report of Special Inspections to the Special Inspector for completion at the completion of the project.
- E. The Statement of Special Inspections will be completed by the Structural Engineer of Record and the Owner and provided to the Contractor after the contracts are signed and returned to the Owner. The Contractor shall submit the completed Statement of Special Inspections to the Building Official for acceptance at the time the building permit is applied for.
- F. The Contractor shall provide incidental labor and facilities to provide access to the work to be inspected or tested, to obtain and handle samples at the site or at source of products to be tested, to facilitate tests and inspections, storage and curing of test samples.
- G. The Contractor shall keep at the project site the latest set of construction drawings, field sketches, approved shop drawings, and specifications for use by the inspectors and testing technicians.
- H. The Special Inspection program shall in no way relieve the Contractor of his obligation to perform work in accordance with the requirements of the Contract Documents or from implementing an effective Quality Control program. All work that is to be subjected to Special Inspections shall first be reviewed by the Contractor's quality control personnel.
- I. The Contractor shall be solely responsible for construction site safety.

1.8 LIMITS ON AUTHORITY

- A. The Special Inspector or Testing Company/Testing Laboratory may not release, revoke, alter, or enlarge on the requirements of the Contract Documents.
- B. The Special Inspector or Testing Company/Testing Laboratory will not have control over the Contractor's means or methods of construction.
- C. The Special Inspector or Testing Company/Testing Laboratory shall not be responsible for construction site safety.
- D. The Special Inspector or Testing Company/Testing Laboratory has no authority to stop the work.

1.9 STATEMENT OF SPECIAL INSPECTIONS

- A. The Statement of Special Inspections will be prepared by the Structural Engineer of Record.
- B. The attached Statement of Special Inspections shall be used.
- C. The Statement of Special Inspections shall be provided to the Contractor after the contracts are signed and returned to the Owner and shall be submitted with the application of Building Permit.

1.10 RECORDS AND REPORTS

- A. Detailed daily reports shall be prepared of each inspection or test and submitted to the Special Inspector. Reports shall include:
 - 1. date of test or inspection
 - 2. name of inspector or technician
 - 3. location of specific areas tested or inspected
 - 4. description of test or inspection and results
 - 5. applicable ASTM standard
 - 6. weather conditions
 - 7. Engineer's seal and signature
- B. The Special Inspector shall submit interim reports to the Building Official at the end of each month which include all inspections and test reports received last week. Copies shall be sent to the SER, Architect and Contractor.
- C. Any discrepancies from the Contract Documents found during a Special Inspection shall be immediately reported to the Contractor. If the discrepancies are not corrected, the Special Inspector shall notify the SER and Building Official. Reports shall document all discrepancies identified and the correction action taken.
- D. The Testing Company/Testing Laboratory shall immediately notify the Special Inspector and the SER by telephone, fax or electronic mail any test results which fail to comply with the requirements of the Contract Documents.
- E. Reports shall be submitted to the Special Inspector within 7 days of the inspection or test. Legible hand written reports may be submitted if final typed copies are not readily available. Formal reports shall follow.
- F. At the completion of the work requiring Special Inspections, each inspection agency and Testing Company/Testing Laboratory shall provide a statement to the Special Inspector that all work was completed in substantial conformance with the Contract Documents and that all appropriate inspections and tests were performed.

1.11 FINAL REPORT OF SPECIAL INSPECTIONS

- A. The Final Report of Special Inspections shall be completed by the Special Inspector and submitted to the SER and Building Official prior to the issuance of a Certificate of Use and Occupancy.
- B. The attached Final Report of Special Inspections shall be used.
- C. The Final Report of Special Inspections will certify that all required inspections have performed and will itemize any discrepancies that were not corrected or resolved.

PART 2 PRODUCTS (not applicable)

PART 3 EXECUTION (not applicable)

Attached are the following forms:

1. Statement of Special Inspections
2. Schedule of Special Inspection Services
3. Quality Assurance Plan
4. Qualifications of Inspectors and Testing Technicians
5. Schedule of Special Inspection Services
6. Final Report of Special Inspections
7. Final Report of Special Inspections (Agent's Final Report)
8. Contractor's Statement of Responsibility
9. Fabricator's Certificate of Compliance

END OF SECTION

Statement of Special Inspections

Project: CCCC - Learning Resource Center First Floor Renovation
Location: Jacksonville, NC
Owner's Representative:
Owner's Address:

This Statement of Special Inspections is submitted as a condition for permit issuance in accordance with the Special Inspection requirements of the 2018 North Carolina State Building Code. It includes a Schedule of Special Inspection Services applicable to this project, the name of the Special Inspector, the identity of other approved agencies retained for conducting Special Inspections, and the required inspector qualifications. This Statement of Special Inspections was prepared by the following Designers of Record:

Structural	Adam Sisk <small>(Type or print name)</small>	 <small>(Signature)</small>	5/24/2024 <small>(Date)</small>
Architectural	<small>(Type or print name)</small>	<small>(Signature)</small>	<small>(Date)</small>
Mechanical	<small>(Type or print name)</small>	<small>(Signature)</small>	<small>(Date)</small>
Other	<small>(Type or print name)</small>	<small>(Signature)</small>	<small>(Date)</small>

The Special Inspector shall keep records of all special inspections and tests and shall furnish reports to the State Construction Office and the Designers of Record. Reports shall indicate if the work inspected or tested was or was not completed in conformance with the approved construction documents. Discovered discrepancies shall be brought to the immediate attention of the Contractor for correction. If such discrepancies are not corrected, the discrepancies shall be brought to the attention of the State Construction Office and the Designers of Record. The Special Inspections program does not relieve the Contractor of his or her responsibilities.

Interim reports shall be submitted to the State Construction Office, Owner, and the Designers of Record.

Interim Report Frequency: Monthly

A Final Report of Special Inspections documenting completion of all required Special Inspections, testing, and correction of any discrepancies should be submitted prior to issuance of a Certificate of Use and Occupancy.

Job Site safety and means and methods of construction are solely the responsibility of the Contractor.

Owner's Authorization

Accepted for the SCO by:

Signature Date 5/23/2024

Signature Date

Schedule of Special Inspection Services^a

The following sheets comprise the required schedule of special inspections for this project. The construction divisions which require special inspections for this project are as follows.

- | | |
|--|--|
| <input checked="" type="checkbox"/> Structural Steel & High Strength Bolting | <input type="checkbox"/> Helical Pile Foundations |
| <input checked="" type="checkbox"/> Welding of Structural Steel | <input type="checkbox"/> Rammed Aggregate Piers & Stone Columns |
| <input checked="" type="checkbox"/> Cold-Formed Steel Deck | <input type="checkbox"/> Sprayed Fire-Resistant Material |
| <input checked="" type="checkbox"/> Open-Web Steel Joists & Joist Girders | <input type="checkbox"/> Mastic & Intumescent Fire-Resistant Coatings |
| <input type="checkbox"/> Cold-Formed Steel Framing | <input type="checkbox"/> Exterior Insulation & Finish System |
| <input checked="" type="checkbox"/> Concrete Construction | <input checked="" type="checkbox"/> Fire-Resistant Penetrations & Joints |
| <input checked="" type="checkbox"/> Masonry Construction ^b | <input type="checkbox"/> Smoke Control |
| <input type="checkbox"/> Wood Construction | <input type="checkbox"/> Retaining Wall & Systems > 5 Feet |
| <input checked="" type="checkbox"/> Soils | <input type="checkbox"/> Special Inspections for Wind Resistance |
| <input checked="" type="checkbox"/> Driven Deep Foundations | <input type="checkbox"/> Special Inspections for Seismic Resistance |
| <input type="checkbox"/> Cast-in-Place Deep Foundations | |

a. The inspection frequency indicated on the following inspection tables are "C" continuous, "P" periodic, & "O" random on a daily basis.

b. Level A is the minimum inspection program for empirically / prescriptively designed masonry in Risk Category I, II or III structures. Level B is the minimum inspection program for empirically / prescriptively designed masonry in Risk Category IV structures and engineered masonry in Risk Category I, II or III structures. Level C is the minimum inspection program for engineered masonry in Risk Category IV structures. Engineered masonry structures are those designed in accordance with portions of the TMS 402-13 / ACI 530-13/ASCE 5-13 other than Part 4 or Appendix A.

Inspection Agents	Firm Name & Point of Contact	Address / Phone / E-mail
1. Special Inspector (SI-1)		
2. Testing Agency (TA-1)		
3. Testing Agency (TA-2)		
4. Geotechnical Engineer (GE-1)		
5. Other (O-1)		

Note: The inspection and testing agent(s) shall be engaged by the Owner or the Registered Design Professional of Record acting as the Owner's agent, and not by the Contractor or Subcontractor whose work is to be inspected or tested. Any conflict of interest must be disclosed to the State Construction Office, prior to commencing work.

Seismic Design Category: A B C D

Basic Wind Speed (V_{asd}): 90-109mph 110-119mph ≥ 120 mph

Wind Exposure Category: B C D

Schedule of Special Inspection Services
Structural Steel and High-Strength Bolting

Inspection Task	Task Req'd	Freq	Reference for Criteria		Agent
			AISC 360	NCBC	
1. Fabricator Certification / Verification of Quality Control Procedures					
a. Verify fabricator qualifications	<input checked="" type="checkbox"/>	C		1704.2.5.1	
b. Review material test reports & certifications	<input checked="" type="checkbox"/>	C	N5.2		
c. Collect certificates of compliance from the steel fabricator at completion of fabrication	<input checked="" type="checkbox"/>	C		1704.5	
2. Inspections Prior to High-Strength Bolting at Pretensioned and Slip-Critical Joints					
a. Collect manufacturer's certifications for fastener materials	<input checked="" type="checkbox"/>	C	Table (Tbl) N5.6-1		
b. Fasteners are marked per ASTM requirements	<input checked="" type="checkbox"/>	P	Tbl N5.6-1		
c. Ensure correct fasteners and bolting procedures are selected for joint details	<input checked="" type="checkbox"/>	P	Tbl N5.6-1		
d. Verify connecting elements, including the appropriate faying surface condition and hole preparation when specified, comply with the construction documents	<input checked="" type="checkbox"/>	P	Tbl N5.6-1		
e. Observe and document pre-installation verification testing by installation personal for fastener assemblies and methods	<input checked="" type="checkbox"/>	P	Tbl N5.6-1		
f. Verify proper storage provided for all fastener components	<input checked="" type="checkbox"/>	P	Tbl N5.6-1		
3. Inspections During High-Strength Bolting at Pretensioned and Slip-Critical Joints					
a. Ensure correct fastener assemblies placed in all holes and washers, when specified, are positioned as required	<input checked="" type="checkbox"/>	P	Tbl N5.6-2		
b. Verify joint brought to snug-tight condition prior to pretensioning	<input checked="" type="checkbox"/>	P	Tbl N5.6-2		
c. Verify fastener components not turned by the wrench prevented from rotating	<input checked="" type="checkbox"/>	P	Tbl N5.6-2		
d. Ensure fasteners are pretensioned in accordance with RCSC, progressing from the most rigid point towards free edges	<input checked="" type="checkbox"/>	P	Tbl N5.6-2		
4. Document acceptance or rejection of bolted connections after high-strength bolting is complete	<input checked="" type="checkbox"/>	C	Tbl N5.6-3		
5. Structural Details					
a. Verify diameter, grade, type and length of anchor rods and other embedded items supporting structural steel	<input checked="" type="checkbox"/>	P	N5.7		
b. Inspection of fabricated assemblies & erected steel framing verifying compliance with the construction documents	<input checked="" type="checkbox"/>	P	N5.7		
6. Composite Construction					
a. Verify placement & installation of steel deck	<input type="checkbox"/>	P	Tbl N6.1		
b. Observe placement and installation of steel headed stud anchors			Tbl N6.1		
c. Document acceptance or rejection of composite construction elements	<input type="checkbox"/>	P	Tbl N6.1		

Schedule of Special Inspection Services
Welding of Structural Steel

Inspection Task	Task Req'd	Freq	Code Reference		Agent
			AISC 360	NCBC	
1. Inspections Prior to Welding			N5.4		
a. Collect & review welding procedure specification (WPS) and verify manufacturer certifications for welding consumables	<input checked="" type="checkbox"/>	C	Table (Tbl) N5.4-1		
b. Confirm weld material type & grade	<input checked="" type="checkbox"/>	P	Tbl N5.4-1		
c. Confirm method of welder identification	<input checked="" type="checkbox"/>	P	Tbl N5.4-1		
d. Inspection of fit-up for groove & fillet welds including access hole configuration & finish	<input checked="" type="checkbox"/>	P	Tbl N5.4-1		
2. Inspections During Welding			N5.4		
a. Verify welder qualifications	<input checked="" type="checkbox"/>	P	Tbl N5.4-2		
b. Verify proper control and handling of welding consumables	<input checked="" type="checkbox"/>	P	Tbl N5.4-2		
c. Monitor environmental conditions	<input checked="" type="checkbox"/>	P	Tbl N5.4-2		
d. Monitor proper implementation of WPS	<input checked="" type="checkbox"/>	P	Tbl N5.4-2		
e. Inspection of welding techniques including no welding over cracked tack welds	<input checked="" type="checkbox"/>	P	Tbl N5.4-2		
3. Inspections After Welding			N5.4, N5.5		
a. Verify welds have been cleaned	<input checked="" type="checkbox"/>	P	Tbl N5.4-3		
b. Confirm the installed size, length and location of welds matches the contract documents	<input checked="" type="checkbox"/>	C	Tbl N5.4-3		
c. Verify welds meet visual acceptance criteria	<input checked="" type="checkbox"/>	C	Tbl N5.4-3		
d. Confirm arc strikes comply with Part 5.28 of AWS D1.1	<input checked="" type="checkbox"/>	C	Tbl N5.4-3		
e. Visually observe web k-area for cracks within 3" of welded doubler plates, continuity plates and stiffeners	<input checked="" type="checkbox"/>	C	Tbl N5.4-3		
f. Backing and weld tabs removed per contract documents	<input checked="" type="checkbox"/>	C	Tbl N5.4-3		
g. Observe and inspect weld repair activities	<input checked="" type="checkbox"/>	C	Tbl N5.4-3		
h. For Risk Category III or IV structures, conduct ultrasonic testing (UT) of CJP groove welds in materials $\geq 5/16"$ at butt, T- and corner joints subject to transversely applied tension loading	<input type="checkbox"/>	C	N.5.5b, N5.5e		
i. For Risk Category II structures, conduct ultrasonic testing (UT) of CJP groove welds in materials $\geq 5/16"$ at butt, T- and corner joints subject to transversely applied tension loading	<input checked="" type="checkbox"/>	P	N.5.5b, N5.5f		
j. Conduct magnetic particle testing (MT) or liquid penetrant testing (PT) at thermally cut surfaces of access holes for rolled section with $t_f > 2"$ and built-up shape with $t_w > 2"$	<input checked="" type="checkbox"/>	C	N5.5c		
k. Radiographic or ultrasonic inspection at joints subject to fatigue	<input type="checkbox"/>	C	N5.5d, Tbl A-3.1		
l. Document acceptance / rejection of welded joints and members	<input checked="" type="checkbox"/>	C	Tbl N5.4-3, N5.5g		

Schedule of Special Inspection Services
Cold-Formed Steel Deck

Inspection Task	Task Req'd	Freq	Reference for Criteria		Agent
			SDI QA/QC	NCBC	
1. Prior to deck placement, verify deck and deck accessories comply with the construction documents	<input checked="" type="checkbox"/>	C	Table (Tbl) 1.1		
2. Inspection Tasks After Deck Placement					
a. Verify the installation of deck & deck accessories complies with the construction documents	<input checked="" type="checkbox"/>	C	Tbl 1.2		
b. Verify that deck materials' mill certifications comply with the construction documents	<input checked="" type="checkbox"/>	C	Tbl 1.2		
3. Inspection Tasks Prior to Deck Welding					
a. Collect welding procedure specification (WPS)	<input checked="" type="checkbox"/>	P	Tbl 1.3		
b. Collect manufacturer certifications for welding consumables	<input checked="" type="checkbox"/>	P	Tbl 1.3		
c. Verify material type and grade	<input checked="" type="checkbox"/>	P	Tbl 1.3		
d. Check welding equipment	<input checked="" type="checkbox"/>	P	Tbl 1.3		
4. Inspection Tasks During Deck Welding					
a. Verify welder qualifications	<input checked="" type="checkbox"/>	P	Tbl 1.4		
b. Verify proper control and handling of welding consumables	<input checked="" type="checkbox"/>	P	Tbl 1.4		
c. Monitor environmental conditions	<input checked="" type="checkbox"/>	P	Tbl 1.4		
d. Monitor proper implementation of WPS	<input checked="" type="checkbox"/>	P	Tbl 1.4		
5. Inspection Tasks After Welding					
a. Verify size and location of welds, including support, sidelap and perimeter welds	<input checked="" type="checkbox"/>	C	Tbl 1.5		
b. Verify welds meet visual acceptance criteria	<input checked="" type="checkbox"/>	C	Tbl 1.5		
c. Observe weld repair activities	<input checked="" type="checkbox"/>	C	Tbl 1.5		
6. Inspection Tasks Prior to Mechanical Fastening					
a. Verify manufacturer installation instructions available for mechanical fasteners	<input checked="" type="checkbox"/>	P	Tbl 1.6		
b. Proper tools available for fastener installation	<input checked="" type="checkbox"/>	P	Tbl 1.6		
c. Verify proper storage of mechanical fasteners	<input type="checkbox"/>	P	Tbl 1.6		
7. Inspection Tasks During Mechanical Fastening					
a. Observe fastener spacing and position	<input checked="" type="checkbox"/>	P	Tbl 1.7		
b. Verify fasteners are installed in accordance with manufacturer's instructions	<input checked="" type="checkbox"/>	P	Tbl 1.7		
8. Inspection Tasks After Mechanical Fastening					
a. Check spacing, type and installation of support fasteners	<input checked="" type="checkbox"/>	C	Tbl 1.8		
b. Check spacing, type, and installation of sidelap fasteners	<input checked="" type="checkbox"/>	C	Tbl 1.8		
c. Check spacing, type, and installation of perimeter fasteners	<input checked="" type="checkbox"/>	C	Tbl 1.8		
d. Verify repair activities	<input checked="" type="checkbox"/>	C	Tbl 1.8		
9. Document acceptance or rejection of deck & deck accessories for all phases of construction	<input checked="" type="checkbox"/>	C	Tbls 1.1 thru 1.8		

Schedule of Special Inspection Services
Open-Web Steel Joists and Joist Girders

Inspection Task	Task Req'd	Freq	Reference for Criteria		Agent
			Standard	NCBC	
1. Fabricator Certification / Verification of Quality Control Procedures					
a. Verify fabricator qualifications	<input checked="" type="checkbox"/>	C		1704.2.5.1	
b. Collect certificate of compliance from steel joist producer at completion of manufacture	<input checked="" type="checkbox"/>	C		1704.5, 2207.5	
2. Observe bolted and welded joist end connections	<input checked="" type="checkbox"/>	P	SJI-K 5.3, 5.6, SJI-LH/DLH 104.4, 104.7, SJI-JG 1004.4, 1004.6, SJI-CJ 104.4, 104.7	Table (Tbl) 1705.2.3	
3. Verify size, spacing and connection of standard horizontal and diagonal bridging	<input checked="" type="checkbox"/>	P	SJI-K 5.4, SJI-LH/DLH 104.5, SJI-JG 1004.5, 1004.9, SJI-CJ 104.5	Tbl 1705.2.3	
4. Verify size, spacing and connection of bridging that differs from the SJI specifications listed by Part 2207.1 of the NCBC	<input checked="" type="checkbox"/>	P		Tbl 1705.2.3	

Schedule of Special Inspection Services
Concrete Construction

Inspection Task	Task Req'd	Freq	Reference for Criteria		Agent
			Standard _a	NCBC	
1. Inspect reinforcement, including prestressing tendons, and verify placement	<input checked="" type="checkbox"/>	P	ACI Ch.20, 25.2, 25.3, 26.6.1-26.6.3	1908.4	
2. Reinforcing Bar Welding:			AWS D1.4		
e. Verify weldability of reinforcing bars other than ASTM A706 and collect reports	<input checked="" type="checkbox"/>	P	ACI 26.6.4	1704.5	
f. Inspect single-pass fillet welds $\leq 5/16"$	<input checked="" type="checkbox"/>	P	ACI 26.6.4		
g. Inspect all welds other than single-pass fillet welds $\leq 5/16"$	<input checked="" type="checkbox"/>	C	ACI 26.6.4		
3. Concrete Anchors:					
a. Inspect anchors cast in concrete	<input checked="" type="checkbox"/>	P	ACI 17.8.2		
b. Inspect adhesive anchors installed in hardened concrete with horizontally or upwardly inclined orientations that resist sustained tension loads	<input checked="" type="checkbox"/>	C	ACI 17.8.2.4		
c. Inspect adhesive anchors installed in hardened concrete with orientations different from Item 3.b	<input checked="" type="checkbox"/>	P	ACI 17.8.2		
d. Inspect mechanical anchors installed in hardened concrete	<input checked="" type="checkbox"/>	P	ACI 17.8.2		
4. Collect mix designs and verify the correct mix used during installation	<input checked="" type="checkbox"/>	P	ACI Ch19, 26.4.3, 26.4.4	1904.1, 1904.2, 1908.2, 1908.3	
5. Prior to concrete placement, fabricate specimens for strength tests, perform slump and air content tests, and determine the temperature of the concrete	<input checked="" type="checkbox"/>	C	ASTM C172, ASTM C31, ACI 26.4, 26.12	1908.10	
6. Inspect concrete and shotcrete placement for proper application techniques	<input checked="" type="checkbox"/>	C	ACI 26.5	1908.6, 1908.7, 1908.8	
7. Collect reports of preconstruction tests for shotcrete when preconstruction tests are required by NCBC Section 1908.4	<input checked="" type="checkbox"/>	C		1704.5, 1908.5	
8. Verify maintenance of specified curing temperature and techniques	<input checked="" type="checkbox"/>	P	ACI 26.5.3-26.5.5	1908.9	
9. Inspections for prestressed concrete					
a. Observe application of prestressing force	<input type="checkbox"/>	C	ACI 26.10		
b. Inspect grouting of bonded prestressing tendons	<input type="checkbox"/>	C	ACI 26.10		
10. Verify concrete strength prior to stressing of PT tendons and prior to removal of shores and forms from PT & mild beams and structural slabs	<input type="checkbox"/>	P	ACI 26.11.2		
11. Inspect erection of precast members	<input type="checkbox"/>	P	ACI 26.8		
12. Inspect formwork for shape, location and dimensions of the concrete member being formed	<input checked="" type="checkbox"/>	P	ACI 26.11.1.2(b)		
13. Collect mill test reports for ASTM A615 rebar used by SFRS special moment frames, special structural walls or coupling beams	<input type="checkbox"/>	C	ACI 20.2.2.5	1704.5	

a. References to "ACI" in this table are to the ACI 318-14.

Schedule of Special Inspection Services
Masonry – Level B

Inspection Task	Task Req'd	Freq	Reference for Criteria		Agent
			TMS 402 _a	TMS 602 _a	
1. Test & verify slump flow & visual stability index as delivered to site for self-consolidating grout	<input checked="" type="checkbox"/>	C	Table (Tbl) 3.1.2	Art. 1.5B.1.b.3	
2. Test & verify f'm & fAAC prior to construction	<input checked="" type="checkbox"/>	C	Tbl 3.1.2	Art. 1.4B	
3. Verify compliance with the approved submittals	<input checked="" type="checkbox"/>	P	Tbl 3.1.2	Art. 1.5	
4. As masonry construction begins, verify that the following are in compliance:					
a. Proportions of site-prepared mortar	<input checked="" type="checkbox"/>	P		Art. 2.1, 2.6A	
b. Construction of mortar joints	<input checked="" type="checkbox"/>	P		Art. 3.3B	
c. Grade and size of prestressing tendons and anchorages	<input type="checkbox"/>	P		Art. 2.4B, 2.4H	
d. Location of reinforcement, connectors and prestressing tendons and anchorages	<input type="checkbox"/>	P		Art. 3.4, 3.6A	
e. Prestressing technique	<input type="checkbox"/>	P		Art. 3.6B	
f. Properties of thin-bed mortar at AAC masonry	<input type="checkbox"/>	C / P _a		Art. 2.1C	
5. Prior to grouting, verify that the following comply:					
a. Grout space is clean, and cleanouts provided when required	<input checked="" type="checkbox"/>	P		Art. 3.2D, 3.2F	
b. Grade, type & size of reinforcement & anchor bolts, & prestressing tendons & anchorage	<input checked="" type="checkbox"/>	P	Sec. 6.1	Art. 2.4, 3.4	
c. Placement of reinforcement, connectors, and prestressing tendons and anchorage	<input checked="" type="checkbox"/>	P	Sec. 6.1, 6.2.1, 6.2.6, 6.2.7	Art.3.2E, 3.4, 3.6A	
d. Proportions of site-prepared grout and prestressing grout for bonded tendons	<input checked="" type="checkbox"/>	P		Art. 2.6B, 2.4G.1.b	
e. Construction and size of mortar joints	<input checked="" type="checkbox"/>	P		Art. 3.3B	
6. Verify during construction:					
a. Size and location of structural elements	<input checked="" type="checkbox"/>	P		Art. 3.3F	
b. Type, size, and location of anchors, including other details of anchorage of masonry to structural members, frames, or other construction	<input checked="" type="checkbox"/>	P	Sec. 1.2.1(e), 6.1.4.3, 6.2.1		
c. Welding of reinforcement	<input checked="" type="checkbox"/>	C	Sec. 8.1.6.7.2, 9.3.3.4(c), 11.3.3.4(b)		
d. Preparation, construction, and protection of masonry during cold weather (temperature < 40°F) or hot weather (temperature > 90°F)	<input checked="" type="checkbox"/>	P		Art. 1.8C, 1.8D	
e. Application & measurement of prestress force	<input type="checkbox"/>	C		Art. 3.6B	
f. Verify placement of grout and prestressing grout for bonded tendons	<input checked="" type="checkbox"/>	C		Art. 3.5, 3.6C	
g. Placement of AAC masonry units and construction of thin-bed mortar joints	<input checked="" type="checkbox"/>	C / P _b		Art. 3.3B.9, 3.3F.1.b	
7. Observe preparation of grout specimens, mortar specimens, and or prisms	<input checked="" type="checkbox"/>	P		Art. 1.4.B.2.a.3, 1.4.B.2.b.3, 1.4.B.2.c.3, 1.4.B.3, 1.4.B.4	

a. References to "TMS402" in this table are to the TMS402/ACI530/ASCE5-13. References to "TMS602" are to TMS602/ACI530.1/ASCE6-13.

b. AAC masonry shall be continuously inspected for the first 5000-square feet and periodically inspected afterwards.

Schedule of Special Inspection Services
Soils

Inspection Task	Task Req'd	Freq	Reference for Criteria		Agents
			Standard	NCBC	
1. Verify materials below shallow foundations are adequate to achieve the design bearing capacity	<input checked="" type="checkbox"/>	P		1705.6	
2. Verify excavations extend to proper depth and have reached the correct soil material	<input checked="" type="checkbox"/>	P		1705.6	
3. Perform classification and testing of compacted fill materials	<input checked="" type="checkbox"/>	P		1705.6	
4. Verify that materials used, densities, lift thickness and procedures used during placement and compaction of compacted fill are in accordance with the approved soils report and the construction documents	<input checked="" type="checkbox"/>	C		1705.6	
5. Prior to placement of compacted fill, verify that the subgrade has been prepared in accordance with the approved soils report and the construction documents	<input checked="" type="checkbox"/>	P		1705.6	

Schedule of Special Inspection Services
 Driven Deep Foundations ^{a b c}

Inspection Task	Task Req'd	Freq	Reference for Criteria		Agents
			Standard	NCBC	
1. Verify that deep foundation materials, sizes and lengths comply with the construction documents	<input checked="" type="checkbox"/>	C		1705.7	
2. Observe pile load tests and determine capacities of test elements ensuring compliance with the construction documents.	<input type="checkbox"/>	C		1705.7	
3. Inspect driving operations and maintain complete and accurate records for each element	<input checked="" type="checkbox"/>	C		1705.7	
4. Verify placement, location, plumbness, hammer size and type, blow count per foot of penetration, required penetrations to achieve design capacity, tip and butt elevations, damage and anomalies	<input checked="" type="checkbox"/>	C		1705.7	

a. For steel elements, perform additional inspections in accordance with Section 1705.2 of the North Carolina Building Code and the applicable Schedules included herein

b. For concrete elements and concrete-filled elements, perform additional inspections in accordance with Section 1705.3 of the North Carolina Building Code and the applicable Schedules included herein

c. For specialty elements, perform additional inspections as determined by the registered design professional in responsible charge and the applicable Schedules included herein

Schedule of Special Inspection Services
 Fire-resistant Penetrations and Joints ^a

Inspection Task	Task Req'd	Freq	Reference for Criteria		Agent
			Standard	NCBC	
1. Inspect through-penetration fire-stop systems at fire walls, fire barriers, smoke barriers and fire partition walls in accordance with ASTM E2174	☒	P		1705.17.1, 714.3.1.2	
2. Inspect penetration firestop systems at penetrations through membranes that are part of a horizontal assembly in accordance with ASTM E2174	☒	P		1705.17.1, 714.4.2	
3. Inspect fire-resistant joint systems in accordance with ASTM 2393	☒	P		1705.17.2, 715.3, 715.4	

a. The inspection of fire-resistant penetrations and joints applies only to high-rise buildings or buildings assigned to Risk Category III or IV.

FINAL REPORT OF SPECIAL INSPECTIONS

Project: CCCC - Learning Resource Center First Floor Renovation

Location: Jacksonville, NC

Owner: Coastal Carolina Community College

Owner's Address: 444 Western Blvd
Jacksonville, NC 28546

Architect of Record: Daniel Hill, AIA

Structural Engineer of Record: Adam Sisk, PE, SE

To the best of my information, knowledge and belief, the Special Inspections required for this project, and itemized in the State of Special Inspections submitted for permit, have been performed and all discovered discrepancies have been reported and resolved other than the following:

Comments:

(Attach continuation sheets if required to complete the description of corrections).

Interim reports submitted prior to this final report form a basis for and are to be considered an integral part of this final report.

Respectfully submitted,
Special Inspector

Licensed Professional Seal

Signature Date

FINAL REPORT OF SPECIAL INSPECTIONS

AGENTS FINAL REPORT

Project: CCCC - Learning Resource Center First Floor Renovation

Agent:

Special Inspector:

To the best of my information, knowledge and belief, the Special Inspections or testing required for this project, and designated for this Agent in the *Statement of Special Inspections* submitted for permit, have been performed and all discovered discrepancies have been reported and resolved other than the following:

Comments:

(Attach continuation sheets if required to complete the description of corrections).

Interim reports submitted prior to this final report form a basis for and are to be considered an integral part of this final report.

Respectfully submitted,

Agent of the Special Inspector

Licensed Professional Seal

Signature

Date

CONTRACTOR’S STATEMENT OF RESPONSIBILITY

Each contractor responsible for the construction or fabrication of a system or component designated in the Quality Assurance Plan must submit a Statement of Responsibility.

Project: CCCC - Learning Resource Center First Floor Renovation

Contractor’s Name:

Address:

License No.:

Description of designated building systems and components included in the Statement of Responsibility:

Contractor’s Acknowledgment of Special Requirements

I hereby acknowledge that I have received, read, and understand the Quality Assurance Plan and Special Inspection program.

I hereby acknowledge that control will be exercised to obtain conformance with the construction documents approved by the Building Official.

Signature

Date

Contractor’s Provisions for Quality Control

Procedures for exercising control within the contractor’s organization, the method and frequency of reporting and the distribution of reports is attached to this Statement.

Identification and qualifications of the person(s) exercising such control and their position(s) in the organization are attached to this Statement.

FABRICATOR'S CERTIFICATE OF COMPLIANCE

Each approved fabricator that is exempt from Special Inspection of shop fabrication and implementation procedures per section 1704.2 of the International Building Code must submit a *Fabricator's Certificate of Compliance* at the completion of fabrication.

Project: CCCC - Learning Resource Center First Floor Renovation

Fabricator's Name:

Address:

Certification or Approval Agency:

Certification Number:

Date of Last Audit or Approval:

Description of structural members and assemblies that have been fabricated:

I hereby certify that items described above were fabricated in strict accordance with the approved construction documents.

Signature

Date

Title

Attach copies of fabricator's certification or building code evaluation service report and fabricator's quality control manual

SECTION 015000 - TEMPORARY FACILITIES AND CONTROLS

PART 1 - GENERAL

1.1 SUMMARY

- A. This Section includes requirements for temporary facilities and controls, including temporary utilities, support facilities, and security and protection facilities.

1.2 DEFINITIONS

- A. Permanent Enclosure: As determined by Architect, permanent or temporary roofing is complete, insulated, and weathertight; exterior walls are insulated and weathertight; and all openings are closed with permanent construction or substantial temporary closures.

1.3 USE CHARGES

- A. General: Cost or use charges for temporary facilities are not chargeable to Owner or Architect and shall be included in the Contract Sum. Allow other entities to use temporary services and facilities without cost, including, but not limited to, Owner's construction forces, Architect, testing and inspecting agencies, and personnel of authorities having jurisdiction.
- B. Water Service: Use water from Owner's existing water system without metering and without payment of use charges. Coordinate with Owner's representative.
- A. Electric Power Service: Use electric power from Owner's existing system without metering and without payment of use charges. Coordinate with Owner's representative.

1.4 QUALITY ASSURANCE

- A. Standards: Comply with ANSI A10.6, NECA's "Temporary Electrical Facilities," and NFPA 241.
 - 1. Electric Service: Comply with NECA, NEMA, and UL standards and regulations for temporary electric service. Install service to comply with NFPA 70.

1.5 PROJECT CONDITIONS

- A. Temporary Utilities: At earliest feasible time, when acceptable to Owner, change over from use of temporary service to use of permanent service.
 - 1. Temporary Use of Permanent Facilities: Installer of each permanent service shall assume responsibility for operation, maintenance, and protection of each permanent service during its use as a construction facility before Owner's acceptance, regardless of previously assigned responsibilities.

- B. Conditions of Use: The following conditions apply to use of temporary services and facilities by all parties engaged in the Work:
 - 1. Keep temporary services and facilities clean and neat.
 - 2. Relocate temporary services and facilities as required by progress of the Work.
- C. The Learning Resource Center Second Floor is intended to be occupied during the course of construction. While the building is occupied, the electricity and mechanical systems shall not be turned off without advance notice. **Notify Owner and Architect 72 hours in advance of turning off any utilities.**

PART 2 - PRODUCTS

2.1 MATERIALS

- A. General: Provide new materials. Undamaged, previously used materials in serviceable condition may be used if approved by Architect. Provide materials suitable for use intended.
- B. Safety Fencing: 4' high, orange safety plastic mesh fencing shall be required to define area of work.
- C. Tarpaulin and Plastic Sheeting: Fire-resistive labeled with flame-spread rating of 15 or less as necessary to protect interior space outside of area of work.
- B. Water: Potable.

2.2 EQUIPMENT

- A. Fire Extinguishers: Hand carried, portable, UL rated. Provide class and extinguishing agent as indicated or a combination of extinguishers of NFPA-recommended classes for exposures.
 - 1. Comply with NFPA 10 and NFPA 241 for classification, extinguishing agent, and size required by location and class of fire exposure.
- B. Self-Contained Toilet Units: Single-occupant units of chemical, aerated recirculation, or combustion type; vented; fully enclosed with a glass-fiber-reinforced polyester shell or similar nonabsorbent material.
- C. Drinking-Water Fixtures: Containerized, tap-dispenser, bottled-water, drinking-water units, including paper cup supply.
- D. Electrical Outlets: Properly configured, NEMA-polarized outlets to prevent insertion of 110- to 120-V plugs into higher-voltage outlets; equipped with ground-fault circuit interrupters, reset button, and pilot light.
- E. Power Distribution System Circuits: Where permitted and overhead and exposed for surveillance, wiring circuits, not exceeding 125-V ac, 20-A rating, and lighting circuits may be nonmetallic sheathed cable.

PART 3 - EXECUTION

3.1 INSTALLATION, GENERAL

- A. Locate facilities where they will serve Project adequately and result in minimum interference with performance of the Work. Relocate and modify facilities as required.
- B. Provide each facility ready for use when needed to avoid delay. Maintain and modify as required. Do not remove until facilities are no longer needed or are replaced by authorized use of completed permanent facilities.

3.2 TEMPORARY UTILITY INSTALLATION

- A. General: Connect to existing services as approved by Coastal Carolina Community College. Where utility company provides only part of the service, provide the remainder with matching, compatible materials, and equipment. Comply with Facilities Department recommendations.
 - 1. Arrange with Owner and existing users for time when service can be interrupted, if necessary, to make connections for temporary services.
- B. Water Service: Use of Owner's existing water service facilities will be permitted, as long as facilities are cleaned and maintained in a condition acceptable to Owner. Prior to Final Acceptance, restore these facilities to condition existing before initial use.
 - 1. Provide rubber hoses as necessary to serve Project site.
 - 2. Routinely wet grounds and demolition areas to retard airborne dust.
- C. Sanitary Facilities: Provide temporary toilets, wash facilities, and drinking-water fixtures. Comply with regulations and health codes for type, number, location, operation, and maintenance of fixtures and facilities.
 - 1. Toilets: Install self-contained toilet units. Shield toilets to ensure privacy.
 - 2. Wash Facilities: Install wash facilities supplied with potable water at convenient locations for personnel who handle materials that require wash up. Dispose of drainage properly. Supply cleaning compounds appropriate for each type of material handled.
- D. Heating and Cooling: Provide temporary heating and cooling required by construction activities for curing or drying of completed installations or for protecting installed construction from adverse effects of low temperatures or high humidity. Select equipment from that specified that will not have a harmful effect on completed installations or elements being installed.
- E. Ventilation and Humidity Control: Provide temporary ventilation required by construction activities for curing or drying of completed installations or for protecting installed construction from adverse effects of high humidity. Select equipment from that specified that will not have a harmful effect on completed installations or elements being installed. Coordinate ventilation requirements to produce ambient condition required and minimize energy consumption.
- F. Electric Power Service: Use of Owner's existing electric power service will be permitted, as long as equipment is maintained in a condition acceptable to Owner.

- G. Electric Distribution: Provide receptacle outlets adequate for connection of power tools and equipment.
 - 1. Provide waterproof connectors to connect separate lengths of electrical power cords if single lengths will not reach areas where construction activities are in progress. Do not exceed safe length-voltage ratio.
- H. Lighting: Provide temporary lighting with local switching that provides adequate illumination for construction operations and traffic conditions.
 - 1. Install and operate temporary lighting that fulfills security and protection requirements without operating entire system.
 - 2. Install exterior-yard site lighting that will provide adequate illumination for construction operations, traffic conditions, and signage visibility when the Work is being performed.
- I. Telephone Service: Provide temporary telephone service throughout construction period for common-use facilities used by all personnel engaged in construction activities. Provide separate telephone capabilities for each field office and first-aid station.
 - 1. Provide additional telephone capabilities for the following:
 - a. Provide a portable cellular telephone for superintendent's use in making and receiving telephone calls when away from field office.
 - 2. At each telephone, post a list of important telephone numbers, including police and fire departments, ambulance service, Contractor's home office, Architect's office, Engineers' offices, Owner's office, and principal subcontractors' field and home offices.

3.3 SUPPORT FACILITIES INSTALLATION

- A. General: Comply with the following:
 - 1. Locate storage sheds, sanitary facilities, and other temporary construction and support facilities for easy access.
 - 2. Provide incombustible construction for offices, shops, and sheds located within construction area or within 30 feet of building lines. Comply with NFPA 241.
- B. Project Identification and Temporary Signs: Prepare temporary signs to provide directional information to construction personnel and visitors as necessary.
 - 1. Prepare temporary signs to provide directional information to inform public and persons seeking entrance to existing building.
- C. Waste Disposal Facilities: Provide waste-collection containers in sizes adequate to handle waste from construction operations. Containerize and clearly label hazardous, dangerous, or unsanitary waste materials separately from other waste. Comply with Division 1 Section "Execution Requirements " for progress cleaning requirements.
 - 1. If required by authorities having jurisdiction, provide separate containers, clearly labeled, for each type of waste material to be deposited.

2. Develop a waste management plan for Work performed on Project. Indicate types of waste materials Project will produce and estimate quantities of each type. Provide detailed information for on-site waste storage and separation of recyclable materials. Provide information on destination of each type of waste material and means to be used to dispose of all waste materials.

D. Storage and Fabrication Sheds: Provide sheds sized, furnished, and equipped to accommodate materials and equipment involved, including temporary utility services. Sheds may be open shelters or fully enclosed spaces within building or elsewhere on-site.

E. Lifts and Hoists: Provide facilities for hoisting materials and personnel. Truck cranes and similar devices used for hoisting materials are considered "tools and equipment" and not temporary facilities.

3.4 SECURITY AND PROTECTION FACILITIES INSTALLATION

A. Environmental Protection: Provide protection, operate temporary facilities, and conduct construction in ways and by methods that comply with environmental regulations and that minimize possible air, waterway, and subsoil contamination or pollution or other undesirable effects. Avoid using tools and equipment that produce harmful noise. Restrict use of noisemaking tools and equipment to hours that will minimize complaints from persons or firms near Project site.

B. Security Enclosure and Lockup: Install substantial temporary enclosure around partially completed areas of construction. Provide lockable entrances to prevent unauthorized entrance, vandalism, theft, and similar violations of security. **Ensure all materials and vehicles on project site are secure.**

C. Barricades, Warning Signs, and Lights: Comply with standards and code requirements for erecting structurally adequate barricades. Paint with appropriate colors, graphics, and warning signs to inform personnel and public of possible hazard. Where appropriate and needed, provide lighting, including flashing red or amber lights.

D. Temporary Fire Protection: Until fire-protection needs are supplied by permanent facilities, install, and maintain temporary fire-protection facilities of types needed to protect against reasonably predictable and controllable fire losses. Comply with NFPA 241.

1. Provide fire extinguishers, installed on walls on mounting brackets, visible and accessible from space being served, with sign mounted above.

a. Locate fire extinguishers where convenient and effective for their intended purpose; provide not less than one extinguisher on each floor at or near each usable stairwell.

2. Store combustible materials in containers in fire-safe locations.

3. Maintain unobstructed access to fire extinguishers, fire hydrants, temporary fire-protection facilities, stairways, and other access routes for firefighting. Prohibit smoking in hazardous fire-exposure areas.

4. Supervise welding operations, combustion-type temporary heating units, and similar sources of fire ignition.

- E. Temporary Enclosures: Provide temporary enclosures for protection of construction, in progress and completed, from exposure, foul weather, other construction operations, and similar activities. Provide temporary weathertight enclosure for building exterior.
 - 1. Where heating or cooling is needed and permanent enclosure is not complete, provide insulated temporary enclosures. Coordinate enclosure with ventilating and material drying or curing requirements to avoid dangerous conditions and effects.
 - 2. Vertical Openings: Close openings of 25 sq. ft. or less with plywood or similar materials.
 - 3. Horizontal Openings: Close openings in floor or roof decks and horizontal surfaces with load-bearing, wood-framed construction.
 - 4. Install tarpaulins securely using fire-retardant-treated wood framing and other materials.

3.5 OPERATION, TERMINATION, AND REMOVAL

- A. Supervision: Enforce strict discipline in use of temporary facilities. To minimize waste and abuse, limit availability of temporary facilities to essential and intended uses.
- B. Maintenance: Maintain facilities in good operating condition until removal. Protect from damage caused by freezing temperatures and similar elements.
 - 1. Maintain operation of temporary enclosures, heating, cooling, humidity control, ventilation, and similar facilities on a 24-hour basis where required to achieve indicated results and to avoid possibility of damage.
- C. Termination and Removal: Remove each temporary facility when need for its service has ended, when it has been replaced by authorized use of a permanent facility, or no later than Final Acceptance. Complete or, if necessary, restore permanent construction that may have been delayed because of interference with temporary facility. Repair damaged Work, clean exposed surfaces, and replace construction that cannot be satisfactorily repaired.
 - 1. Materials and facilities that constitute temporary facilities are the property of Contractor. Owner reserves right to take possession of Project identification signs.
 - 2. Prior to Final Acceptance, clean and renovate permanent facilities used during construction period.

3.6 EMERGENCIES

- A. Maintenance: Maintain facilities in good operating condition until removal. Protect from damage caused by freezing temperatures and similar elements.

END OF SECTION 015000

SECTION 017300 - EXECUTION REQUIREMENTS

PART 1 - GENERAL

1.1 SUMMARY

- A. This Section includes general procedural requirements governing execution of the Work including, but not limited to, the following:
 - 1. Field engineering and surveying.
 - 2. General installation of products.
 - 3. Progress cleaning.
 - 4. Starting and adjusting.
 - 5. Protection of installed construction.
 - 6. Correction of the Work.
- B. See Division 1 Section "Closeout Procedures" for submitting final property survey with Project Record Documents, recording of Owner-accepted deviations from indicated lines and levels, and final cleaning.

PART 2 - PRODUCTS (Not Used)

PART 3 - EXECUTION

3.1 EXAMINATION

- A. Existing Conditions: The existence and location of site improvements, utilities, and other construction indicated as existing are not guaranteed. Before beginning work, investigate and verify the existence and location of mechanical and electrical systems and other construction affecting the Work.
 - 1. Before construction, verify the location and points of connection of utility services.
- B. Existing Utilities: The existence and location of underground and other utilities and construction indicated as existing are not guaranteed. Before beginning sitework, investigate and verify the existence and location of underground utilities and other construction affecting the Work.
- C. Acceptance of Conditions: Examine substrates, areas, and conditions, with Installer or Applicator present where indicated, for compliance with requirements for installation tolerances and other conditions affecting performance. Record observations.
 - 1. Verify compatibility with and suitability of substrates, including compatibility with existing finishes or primers.
 - 2. Examine roughing-in for mechanical and electrical systems to verify actual locations of connections before equipment and fixture installation.

3. Proceed with installation only after unsatisfactory conditions have been corrected. Proceeding with the Work indicates acceptance of surfaces and conditions.

3.2 PREPARATION

- A. Existing Utility Information: Furnish information to local utility that is necessary to adjust, move, or relocate existing utility structures, utility poles, lines, services, or other utility appurtenances located in or affected by construction. Coordinate with authorities having jurisdiction.
- B. Field Measurements: Take field measurements as required to fit the Work properly. Recheck measurements before installing each product. Where portions of the Work are indicated to fit to other construction, verify dimensions of other construction by field measurements before fabrication. Coordinate fabrication schedule with construction progress to avoid delaying the Work.
- C. Space Requirements: Verify space requirements and dimensions of items shown diagrammatically on Drawings.
- D. Review of Contract Documents and Field Conditions: Immediately on discovery of the need for clarification of the Contract Documents, submit a request for information to Architect. Include a detailed description of problem encountered, together with recommendations for changing the Contract Documents.

3.3 INSTALLATION

- A. General: Locate the Work and components of the Work accurately, in correct alignment and elevation, as indicated.
 1. Make vertical work plumb and make horizontal work level.
 2. Where space is limited, install components to maximize space available for maintenance and ease of removal for replacement.
 3. Conceal pipes, ducts, and wiring in finished areas, unless otherwise indicated.
- B. Comply with manufacturer's written instructions and recommendations for installing products in applications indicated.
- C. Install products at the time and under conditions that will ensure the best possible results. Maintain conditions required for product performance until Final Acceptance.
- D. Conduct construction operations so no part of the Work is subjected to damaging operations or loading in excess of that expected during normal conditions of occupancy.
- E. Anchors and Fasteners: Provide anchors and fasteners as required to anchor each component securely in place, accurately located and aligned with other portions of the Work.
 1. Mounting Heights: Where mounting heights are not indicated, mount components at heights directed by Architect.
 2. Allow for building movement, including thermal expansion and contraction.

- F. Joints: Make joints of uniform width. Where joint locations in exposed work are not indicated, arrange joints for the best visual effect. Fit exposed connections together to form hairline joints.
- G. Hazardous Materials: Use products, cleaners, and installation materials that are not considered hazardous.

3.4 PROGRESS CLEANING

- A. General: Clean Project site and work areas daily, including common areas. Coordinate progress cleaning for joint-use areas where more than one installer has worked. Enforce requirements strictly. Dispose of materials lawfully.
 - 1. Comply with requirements in NFPA 241 for removal of combustible waste materials and debris.
 - 2. Do not hold materials more than 7 days during normal weather or 3 days if the temperature is expected to rise above 80 deg F.
 - 3. Containerize hazardous and unsanitary waste materials separately from other waste. Mark containers appropriately and dispose of legally, according to regulations.
- B. Site: Maintain Project site free of waste materials and debris.
- C. Installed Work: Keep installed work clean. Clean installed surfaces according to written instructions of manufacturer or fabricator of product installed, using only cleaning materials specifically recommended. If specific cleaning materials are not recommended, use cleaning materials that are not hazardous to health or property and that will not damage exposed surfaces.
- D. Concealed Spaces: Remove debris from concealed spaces before enclosing the space.
- E. Waste Disposal: Burying or burning waste materials on-site will not be permitted. Washing waste materials down sewers or into waterways will not be permitted.
- F. During handling and installation, clean and protect construction in progress and adjoining materials already in place. Apply protective covering where required to ensure protection from damage or deterioration at Substantial Completion.
- G. Clean and provide maintenance on completed construction as frequently as necessary through the remainder of the construction period. Adjust and lubricate operable components to ensure operability without damaging effects.
- H. Limiting Exposures: Supervise construction operations to assure that no part of the construction, completed or in progress, is subject to harmful, dangerous, damaging, or otherwise deleterious exposure during the construction period.

3.5 STARTING AND ADJUSTING

- A. Start equipment and operating components to confirm proper operation. Remove malfunctioning units, replace with new units, and retest.
- B. Adjust operating components for proper operation without binding. Adjust equipment for proper operation.

- C. Test each piece of equipment to verify proper operation. Test and adjust controls and safeties. Replace damaged and malfunctioning controls and equipment.

3.6 PROTECTION OF INSTALLED CONSTRUCTION

- A. Provide final protection and maintain conditions that ensure installed Work is without damage or deterioration at time of Final Acceptance.
- B. Comply with manufacturer's written instructions for temperature and relative humidity.

3.7 CORRECTION OF THE WORK

- A. Repair or remove and replace defective construction. Restore damaged substrates and finishes. Comply with requirements in Division 1 Section "Cutting and Patching."
 - 1. Repairing includes replacing defective parts, refinishing damaged surfaces, touching up with matching materials, and properly adjusting operating equipment.
- B. Restore permanent facilities used during construction to their specified condition.
- C. Remove and replace damaged surfaces that are exposed to view if surfaces cannot be repaired without visible evidence of repair.
- D. Repair components that do not operate properly. Remove and replace operating components that cannot be repaired.
- E. Remove and replace chipped, scratched, and broken glass or reflective surfaces.

END OF SECTION 017300

SECTION 017310 - CUTTING AND PATCHING

PART 1 - GENERAL

1.1 SUMMARY

- A. This Section includes procedural requirements for cutting and patching.
- B. See Divisions 2 through 16 Sections for specific requirements and limitations applicable to cutting and patching individual parts of the Work.

1.2 QUALITY ASSURANCE

- A. Structural Elements: Do not cut and patch structural elements in a manner that could change their load-carrying capacity or load-deflection ratio.
- B. Operational Elements: Do not cut and patch operating elements and related components in a manner that results in reducing their capacity to perform as intended or that results in increased maintenance or decreased operational life or safety.
- C. Visual Requirements: Do not cut and patch construction in a manner that results in visual evidence of cutting and patching. Do not cut and patch construction exposed on the exterior or in occupied spaces in a manner that would, in Architect's opinion, reduce the building's aesthetic qualities. Remove and replace construction that has been cut and patched in a visually unsatisfactory manner.

PART 2 - PRODUCTS

2.1 MATERIALS

- A. General: Comply with requirements specified in other Sections of these Specifications.
- B. Existing Materials: Use materials identical to existing materials. For exposed surfaces, use materials that visually match existing adjacent surfaces to the fullest extent possible.
 - 1. If identical materials are unavailable or cannot be used, use materials that, when installed, will match the visual and functional performance of existing materials.

PART 3 - EXECUTION

3.1 EXAMINATION

- A. Examine surfaces to be cut and patched and conditions under which cutting and patching are to be performed.

1. Compatibility: Before patching, verify compatibility with and suitability of substrates, including compatibility with existing finishes or primers.
2. Proceed with installation only after unsafe or unsatisfactory conditions have been corrected.

3.2 PREPARATION

- A. Temporary Support: Provide temporary support of Work to be cut.
- B. Protection: Protect existing construction during cutting and patching to prevent damage. Provide protection from adverse weather conditions for portions of Project that might be exposed during cutting and patching operations.
- C. Adjoining Areas: Avoid interference with use of adjoining areas or interruption of free passage to adjoining areas.
- D. Existing Services: Where existing services are required to be removed, relocated, or abandoned, bypass such services before cutting to avoid interruption of services to occupied areas.

3.3 PERFORMANCE

- A. General: Employ skilled workers to perform cutting and patching. Proceed with cutting and patching at the earliest feasible time, and complete without delay.
 1. Cut existing construction to provide for installation of other components or performance of other construction, and subsequently patch as required to restore surfaces to their original condition.
- B. Cutting: Cut existing construction by sawing, drilling, breaking, chipping, grinding, and similar operations, including excavation, using methods least likely to damage elements retained or adjoining construction. If possible, review proposed procedures with original Installer; comply with original Installer's written recommendations.
 1. In general, use hand or small power tools designed for sawing and grinding, not hammering and chopping. Cut holes and slots as small as possible, neatly to size required, and with minimum disturbance of adjacent surfaces. Temporarily cover openings when not in use.
 2. Existing Finished Surfaces: Cut or drill from the exposed or finished side into concealed surfaces.
 3. Concrete: Cut using a cutting machine, such as an abrasive saw or a diamond-core drill.
 4. Mechanical and Electrical Services: Cut off pipe or conduit in walls or partitions to be removed. Cap, valve, or plug and seal remaining portion of pipe or conduit to prevent entrance of moisture or other foreign matter after cutting.
 5. Proceed with patching after construction operations requiring cutting are complete.
- C. Patching: Patch construction by filling, repairing, refinishing, closing up, and similar operations following performance of other Work. Patch with durable seams that are as invisible as possible. Provide materials and comply with installation requirements specified in other Sections of these Specifications.

1. Inspection: Where feasible, test and inspect patched areas after completion to demonstrate integrity of installation.
2. Exposed Finishes: Restore exposed finishes of patched areas and extend finish restoration into retained adjoining construction in a manner that will eliminate evidence of patching and refinishing.
3. Floors and Walls: Where walls or partitions that are removed extend one finished area into another, patch and repair floor and wall surfaces in the new space. Provide an even surface of uniform finish, color, texture, and appearance. Remove existing floor and wall coverings and replace with new materials, if necessary, to achieve uniform color and appearance.
4. Ceilings: Patch, repair, or rehang existing ceilings as necessary to provide an even-plane surface of uniform appearance.

END OF SECTION 017310

SECTION 017700 - CLOSEOUT PROCEDURES

PART 1 - GENERAL

1.1 SUMMARY

- A. This Section includes administrative and procedural requirements for contract closeout, including, but not limited to, the following:
 - 1. Inspection procedures.
 - 2. Project Record Documents.
 - 3. As-Built Survey and Site Plan.
 - 4. Operation and maintenance manuals.
 - 5. Warranties.
 - 6. Instruction of Owner's personnel.
 - 7. Final cleaning.
- B. See Division 1 Section "Payment Procedures" for requirements for Applications for Payment for Final Completion.
- C. See Divisions 2 through 16 Sections for specific closeout and special cleaning requirements for products of those Sections.

1.2 FINAL COMPLETION

- A. Inspection: Submit a written request for final inspection for acceptance. On receipt of request, Architect will either proceed with inspection or notify Contractor of unfulfilled requirements. Architect will prepare a final Certificate for Payment after inspection or will notify Contractor of construction that must be completed or corrected before certificate will be issued.
 - 1. Reinspection: Request reinspection when the Work identified in previous inspections as incomplete is completed or corrected.

1.3 LIST OF INCOMPLETE ITEMS (PUNCH LIST)

- A. Preparation: Submit two copies of list. Include name and identification of each space and area affected by construction operations for incomplete items and items needing correction including, if necessary, areas disturbed by Contractor that are outside the limits of construction.
 - 1. Organize list of spaces in sequential order, starting with exterior areas first and proceeding from lowest floor to highest floor.
 - 2. Organize items applying to each space by major element, including categories for ceiling, individual walls, floors, equipment, and building systems.

1.4 PROJECT RECORD DOCUMENTS

- A. General: Do not use Project Record Documents for construction purposes. Protect Project Record Documents from deterioration and loss. Provide access to Project Record Documents for Architect's reference during normal working hours.
- B. Record Drawings: Maintain and submit one set of blue- or black-line white prints of Contract Drawings and Shop Drawings.
 - 1. Mark Record Prints to show the actual installation where installation varies from that shown originally. Require individual or entity who obtained record data, whether individual or entity is Installer, subcontractor, or similar entity, to prepare the marked-up Record Prints.
 - 2. Mark record sets with erasable, red-colored pencil. Use other colors to distinguish between changes for different categories of the Work at the same location.
 - 3. Note Construction Change Directive numbers, Change Order numbers, alternate numbers, and similar identification where applicable.
 - 4. Identify and date each Record Drawing; include the designation "PROJECT RECORD DRAWING" in a prominent location. Provide to Architect.
- C. Record Specifications: Submit one copy of Project's Specifications, including addenda and contract modifications. Mark copy to indicate the actual product installation where installation varies from that indicated in Specifications, addenda, and contract modifications. Provide to Architect.
 - 1. Give particular attention to information on concealed products and installations that cannot be readily identified and recorded later.
 - 2. Mark copy with the proprietary name and model number of products, materials, and equipment furnished, including substitutions and product options selected.
 - 3. Note related Change Orders and Record Drawings, where applicable.
- D. From the contractor's Record Drawings and Specifications furnished to the Architect, the Architect will provide the Owner with Final Electronic Record Documents.
- E. As-Built Survey and Site Plan:
 - 1. The contractor will employ an engineer or land surveyor licensed in the State of North Carolina to provide accurate reproducible as-built drawings to the owner upon completion of construction. Upon checking by the owner any discrepancies will be indicated, then these plans shall be returned to the contractor for correction prior to final payment and final inspection.
 - 2. Payment: No separate payment will be made for as-built drawings. All costs incurred by the contractor for this work should be included in the unit price or lump sum price for the item of work to which it pertains.
 - a. The following items shall be surveyed for as-built condition:
 - b. Stormwater Pond: Survey shall contain pond bottom elevation, outlet structure, elevation contours above normal pool.
 - c. Water System: Horizontal location of waterline.
 - d. Sewer System: Horizontal location of sewer pipe and manholes and invert elevations of sewer within each manhole.

- e. HVAC Piping: Horizontal location of underground HVAC piping.
- f. Surveyed elevations of stair treads, risers, and landings.

1.5 OPERATION AND MAINTENANCE MANUALS

- A. Assemble two complete sets of operation and maintenance data indicating the operation and maintenance of each system, subsystem, and piece of equipment not part of a system. Include operation and maintenance data required in individual Specification Sections and as follows:
 - 1. Operation Data: Include emergency instructions and procedures, system and equipment descriptions, operating procedures, and sequence of operations.
 - 2. Maintenance Data: Include manufacturer's information, list of spare parts, maintenance procedures, maintenance and service schedules for preventive and routine maintenance, and copies of warranties and bonds.
- B. Organize operation and maintenance manuals into suitable sets of manageable size. Bind and index data in heavy-duty, three-ring, vinyl-covered, loose-leaf binders, in thickness necessary to accommodate contents, with pocket inside the covers to receive folded oversized sheets. Identify each binder on front and spine with the printed title "OPERATION AND MAINTENANCE MANUAL," Project name, and subject matter of contents.

1.6 WARRANTIES

- A. Organize warranty documents into an orderly sequence based on the table of contents of the Project Manual.
 - 1. Bind warranties and bonds in heavy-duty, 3-ring, vinyl-covered, loose-leaf binders, thickness as necessary to accommodate contents, and sized to receive 8-1/2-by-11-inch paper. Provide two copies.
 - 2. Provide heavy paper dividers with plastic-covered tabs for each separate warranty. Mark tab to identify the product or installation. Provide a typed description of the product or installation, including the name of the product and the name, address, and telephone number of Installer.
 - 3. Identify each binder on the front and spine with the typed or printed title "WARRANTIES," Project name, and name of Contractor.

PART 2 - PRODUCTS

2.1 MATERIALS

- A. Cleaning Agents: Use cleaning materials and agents recommended by manufacturer or fabricator of the surface to be cleaned. Do not use cleaning agents that are potentially hazardous to health or property or that might damage finished surfaces.

PART 3 - EXECUTION

3.1 DEMONSTRATION AND TRAINING

- A. Instruction: Instruct Owner's personnel to adjust, operate, and maintain systems, subsystems, and equipment not part of a system.
 - 1. Provide instructors experienced in operation and maintenance procedures.
 - 2. Provide instruction at mutually agreed-on times. For equipment that requires seasonal operation, provide similar instruction at the start of each season.
 - 3. Schedule training with Owner, through Architect, with at least seven days' advance notice.

3.2 FINAL CLEANING

- A. Cleaning: Employ experienced workers or professional cleaners for final cleaning. Clean each surface or unit to condition expected in an average commercial building cleaning and maintenance program. Comply with manufacturers written instructions.
 - 1. Complete the following cleaning operations before requesting inspection for certification of Final Acceptance for entire Project or for a portion of Project:
 - a. Clean Project site, yard, and grounds, in areas disturbed by construction activities, including landscape development areas, of rubbish, waste material, litter, and other foreign substances.
 - b. Sweep paved areas broom clean. Remove petrochemical spills, stains, and other foreign deposits.
 - c. Rake grounds that are neither planted nor paved to a smooth, even-textured surface.
 - d. Remove tools, construction equipment, machinery, and surplus material from Project site.
 - e. Clean exposed exterior and interior hard-surfaced finishes to a dirt-free condition, free of stains, films, and similar foreign substances. Avoid disturbing natural weathering of exterior surfaces. Restore reflective surfaces to their original condition.
 - f. Remove debris and surface dust from limited access spaces, including roofs, plenums, shafts, trenches, equipment vaults, manholes, attics, and similar spaces.
 - g. Sweep concrete floors broom-clean in unoccupied spaces.
 - h. Vacuum carpet and similar soft surfaces, removing debris and excess nap; shampoo if visible soil or stains remain.
 - i. Clean transparent materials, including mirrors and glass in doors and windows. Remove glazing compounds and other noticeable, vision-obscuring materials. Replace chipped or broken glass and other damaged transparent materials. Polish mirrors and glass, taking care not to scratch surfaces.
 - j. Remove labels that are not permanent.
 - k. Touch up and otherwise repair and restore marred, exposed finishes and surfaces. Replace finishes and surfaces that cannot be satisfactorily repaired or restored or that already show evidence of repair or restoration.

- 1) Do not paint over "UL" and similar labels, including mechanical and electrical nameplates.
 - l. Wipe surfaces of mechanical and electrical equipment, elevator equipment, and similar equipment. Remove excess lubrication, paint and mortar droppings, and other foreign substances.
 - m. Replace parts subject to unusual operating conditions.
 - n. Clean plumbing fixtures to a sanitary condition, free of stains, including stains resulting from water exposure.
 - o. Replace disposable air filters and clean permanent air filters. Clean exposed surfaces of diffusers, registers, and grills.
 - p. Clean light fixtures, lamps, globes, and reflectors to function with full efficiency. Replace burned-out bulbs, and those noticeably dimmed by hours of use, and defective and noisy starters in fluorescent and mercury vapor fixtures to comply with requirements for new fixtures.
 - q. Replace all worn, warped, or marred pier deck or railing components.
 - r. Leave Project clean and ready for occupancy.
- B. Pest Control: Engage an experienced, licensed exterminator to make a final inspection and rid Project of rodents, insects, and other pests. Prepare a report.

END OF SECTION 017700

SECTION 023610 - TERMITE CONTROL

PART 1 - GENERAL

1.1 SUMMARY

- A. This Section includes the following:
 - 1. Soil treatment with termiticide.
- B. See Division 6 Section "Rough Carpentry" for wood preservative treatment by pressure process.

1.2 SUBMITTALS

- A. Product Data: For each type of product indicated. Include the EPA-Registered Label.
- B. Product certificates.
- C. Soil Treatment Application Report: Include the following:
 - 1. Date and time of application.
 - 2. Moisture content of soil before application.
 - 3. Brand name and manufacturer of termiticide.
 - 4. Quantity of undiluted termiticide used.
 - 5. Dilutions, methods, volumes, and rates of application used.
 - 6. Areas of application.
 - 7. Water source for application.

1.3 QUALITY ASSURANCE

- A. Installer Qualifications: A specialist who is licensed according to regulations of authorities having jurisdiction to apply termite control treatment and products in jurisdiction where Project is located.
- B. Regulatory Requirements: Formulate and apply termiticides according to the EPA-Registered Label.

1.4 WARRANTY

- A. Special Warranty: Manufacturer's standard form, signed by Applicator and Contractor certifying that termite control work, consisting of applied soil termiticide treatment, will prevent infestation of subterranean termites. If subterranean termite activity or damage is discovered during warranty period, re-treat soil and repair or replace damage caused by termite infestation.
 - 1. Warranty Period: Three years from date of Final Acceptance.

1.5 MAINTENANCE SERVICE

- A. Continuing Service: Beginning at Final Acceptance, provide 12 months' continuing service including monitoring, inspection, and re-treatment for occurrences of termite activity. Provide a standard continuing service agreement. State services, obligations, conditions, and terms for agreement period; and terms for future renewal options.

PART 2 - PRODUCTS

2.1 MANUFACTURERS

- A. Available Manufacturers: Subject to compliance with requirements, manufacturers offering products that may be incorporated into the Work include, but are not limited to, the following:
- B. Manufacturers: Subject to compliance with requirements, provide products by one of the following:
 - 1. Termiticides:
 - a. Aventis Environmental Science USA LP; Termidor.
 - b. Premise, Bayer Corporation.
 - c. FMC Corporation, Agricultural Products Group; Talstar.

2.2 SOIL TREATMENT

- A. Termiticide: Provide an EPA-registered termiticide complying with requirements of authorities having jurisdiction, in an aqueous solution formulated to prevent termite infestation. Provide quantity required for application at the label volume and rate for the maximum termiticide concentration allowed for each specific use, according to product's EPA-Registered Label.
- B. Termiticide: Provide an EPA-registered termiticide approved for use in North Carolina by the North Carolina Department of Agriculture.

PART 3 - EXECUTION

3.1 PREPARATION

- A. General: Remove all extraneous sources of wood cellulose and other edible materials such as wood debris, tree stumps and roots, stakes, formwork, and construction waste wood from soil within and around foundations.
- B. Soil Treatment Preparation: Loosen, rake, and level soil to be treated except previously compacted areas under slabs and footings. Termiticides may be applied before placing compacted fill under slabs if recommended in writing by termiticide manufacturer.

3.2 APPLYING SOIL TREATMENT

- A. Application: Mix soil treatment termiticide solution to a uniform consistency. Provide quantity required for application at the label volume and rate for the maximum specified concentration of termiticide, according to manufacturer's EPA-Registered Label, to the following so that a continuous horizontal and vertical termiticidal barrier or treated zone is established around and under building construction. Distribute treatment evenly.
 - 1. Slabs-on-Grade: Under ground-supported slab construction, including footings, building slabs, and attached slabs as an overall treatment. Treat soil materials before concrete footings and slabs are placed.
 - 2. Foundations: Adjacent soil including soil along the entire inside perimeter of foundation walls, along both sides of interior partition walls, around plumbing pipes and electric conduit penetrating the slab, and around interior column footers, piers, and chimney bases; also along the entire outside perimeter, from grade to bottom of footing. Avoid soil washout around footings.
 - 3. Masonry: Treat voids.
 - 4. Penetrations: At expansion joints, control joints, and areas where slabs will be penetrated.
- B. Avoid disturbance of treated soil after application. Keep off treated areas until completely dry.
- C. Protect termiticide solution, dispersed in treated soils and fills, from being diluted until ground-supported slabs are installed. Use waterproof barrier according to EPA-Registered Label instructions.
- D. Post warning signs in areas of application.
- E. Reapply soil treatment solution to areas disturbed by subsequent excavation, grading, landscaping, or other construction activities following application.

END OF SECTION 023610

SECTION 024119 - SELECTIVE DEMOLITION

PART 1 - GENERAL

1.1 SUMMARY

- A. This Section includes demolition and removal of the following:
 - 1. Selected portions of the existing building.
 - 2. Repair procedures for selective demolition operations.

1.2 DEFINITIONS

- A. Remove: Detach items from existing construction and legally dispose of them off-site, unless indicated to be removed and salvaged or removed and reinstalled.
- B. Remove and Salvage: Detach items from existing construction and deliver them to Owner.
- C. Remove and Reinstall: Detach items from existing construction, prepare them for reuse, and reinstall them where indicated.
- D. Existing to Remain: Existing items of construction that are not to be removed and that are not otherwise indicated to be removed, removed and salvaged, or removed and reinstalled.

1.3 MATERIALS OWNERSHIP

- A. Except for items or materials indicated to be reused, salvaged, reinstalled, or otherwise indicated to remain Owner's property, demolished materials shall become Contractor's property and shall be removed from Project site.

1.4 QUALITY ASSURANCE

- A. Demolition Firm Qualifications: An experienced firm that has specialized in demolition work similar in material and extent to that indicated for this Project.
- B. Regulatory Requirements: Comply with governing EPA notification regulations before beginning selective demolition. Comply with hauling and disposal regulations of authorities having jurisdiction.
- C. Standards: Comply with ANSI A10.6 and NFPA 241.
- D. Predemolition Conference: Conduct conference at Project site.

1.5 PROJECT CONDITIONS

- A. Utility Service: Maintain existing utilities indicated to remain in service and protect them against damage during selective demolition operations.

PART 2 - PRODUCTS

2.1 REPAIR MATERIALS

- A. Use repair materials identical to existing materials.
 - 1. If identical materials are unavailable or cannot be used for exposed surfaces, use materials that visually match existing adjacent surfaces to the fullest extent possible.
 - 2. Use materials whose installed performance equals or surpasses that of existing materials.

PART 3 - EXECUTION

3.1 EXAMINATION

- A. Verify that utilities have been disconnected and capped.
- B. Survey existing conditions and correlate with requirements indicated to determine extent of selective demolition required.
- C. Inventory and record the condition of items to be removed and reinstalled and items to be removed and salvaged.
- D. When unanticipated mechanical, electrical, or structural elements that conflict with intended function or design are encountered, investigate and measure the nature and extent of conflict. Promptly submit a written report to Architect.
- E. Engage a professional engineer to survey condition of building to determine whether removing any element might result in structural deficiency or unplanned collapse of any portion of structure or adjacent structures during selective demolition operations.

3.2 UTILITY SERVICES

- A. Existing Utilities: Maintain services indicated to remain and protect them against damage during selective demolition operations.
- B. Utility Requirements: Locate, identify, disconnect, and seal or cap off indicated utilities serving areas to be selectively demolished.
 - 1. Arrange to shut off indicated utilities with utility companies.
 - 2. Cut off pipe or conduit in walls or partitions to be removed. Cap, valve, or plug and seal remaining portion of pipe or conduit after bypassing.

3.3 SELECTIVE DEMOLITION

- A. General: Demolish and remove existing construction only to the extent required by new construction and as indicated. Use methods required to complete the Work within limitations of governing regulations.
 - 1. Neatly cut openings and holes plumb, square, and true to dimensions required. Use cutting methods least likely to damage construction to remain or adjoining construction.
 - 2. Cut or drill from the exposed or finished side into concealed surfaces to avoid marring existing finished surfaces.
 - 3. Do not use cutting torches until work area is cleared of flammable materials. At concealed spaces, such as duct and pipe interiors, verify condition and contents of hidden space before starting flame-cutting operations. Maintain portable fire-suppression devices during flame-cutting operations.
 - 4. Locate selective demolition equipment and remove debris and materials so as not to impose excessive loads on supporting walls, floors, or framing.

3.4 PATCHING AND REPAIRS

- A. General: Promptly repair damage to adjacent construction caused by selective demolition operations.
- B. Repairs: Where repairs to existing surfaces are required, patch to produce surfaces suitable for new materials.
 - 1. Completely fill holes and depressions in existing masonry walls that are to remain with an approved masonry patching material applied according to manufacturer's written recommendations.
- C. Finishes: Restore exposed finishes of patched areas and extend restoration into adjoining construction in a manner that eliminates evidence of patching and refinishing.
- D. General: Promptly dispose of demolished materials. Do not allow demolished materials to accumulate on-site.
- E. Burning: Do not burn demolished materials.
- F. Disposal: Transport demolished materials off Owner's property and legally dispose of them.

END OF SECTION 024119

SECTION 028300 – ASBESTOS ABATEMENT

An early release demolition contract has been let by Coastal Carolina Community College. Asbestos Abatement within project area is a part of the early release demolition contract. Clearances reports for the Learning Resource Center on the main campus of Coastal Carolina Community College may be obtained from the owner's representative.

SECTION 028300 – LEAD PAINT NOTIFICATION

The contractor is notified that the Coastal Carolina Community College Learning Resource Center Renovation contains existing lead paint. Limited areas of the building have tested positive for lead paint. Reference the report from Phoenix EnviroCorp describing full test results of the facility. The contractor should make all provisions required to safely remove and dispose of lead paint materials. Removal and disposal and cleaning must comply with all local, state and federal requirements as well as OSHA removal guidelines. Waste material must be identified as containing lead-based materials and disposed of as hazardous materials in a certified disposal site approved for lead paint. All areas of paint removal should be cleaned prior to the start of renovation activities. The owner will conduct independent testing to verify lead has been removed or encapsulated prior to the contractor's release for renovation activities.

This report was revised on December 20, 2019 for clarification.
The original report was dated December 13, 2019.



December 20, 2019

Carol Lurz
Coastal Carolina Community College
444 Western Boulevard
Jacksonville, NC 28546

RE: PEC Job # 21-19-290-Pb-I; Learning Resource Center, 2nd floor, 444 Western Boulevard, Jacksonville, NC– Lead Paint Chip Inspection

Enclosed are the results of the lead paint chip samples collected by Phoenix EnviroCorp (PEC) from the above referenced building on December 9, 2019.

Sample analysis was performed via Flame Atomic Absorption Spectroscopy, EPA SW-846 Ed Method No. 3050B/Method No. 7000B.

Sample Collection:

Each sample was collected and placed into a separate plastic container, assigned a unique identification number, and shipped to a third party laboratory for analysis. Please see the enclosed photographic documentation for a description of sample locations.

At the completion of on-site sampling, a total of sixteen (16) samples were collected. The identification number, the location of each sample, and the sample results are as follows; results are reported as percent by weight (% by weight). Results with less than (<) sign are below the reporting limit.

<u>Sample ID#</u>	<u>Location</u>	<u>Results</u>
120919-SM-01	White concrete beams	0.019 %
120919-SM-02	White concrete beams	<0.009%
120919-SM-03	White drywall walls	<0.009%
120919-SM-04	White drywall walls	<0.009%
120919-SM-05	Yellow concrete walls	<0.008%
120919-SM-06	Yellow concrete walls	<0.010%
120919-SM-07	Yellow metal fixed ladder	0.141%
120919-SM-08	Yellow metal fixed ladder	0.015%
120919-SM-09	White concrete walls	<0.009%

This report was revised on December 20, 2019 for clarification.
The original report was dated December 13, 2019.

120919-SM-10	White concrete walls	< 0.010%
120919-SM-11	White metal door frames	0.957%
120919-SM-12	White metal door frames	0.397%
120919-SM-13	Brown metal elevator exterior	0.120%
120919-SM-14	Brown metal elevator exterior	0.011%
120919-SM-15	Yellow metal stair railing	13.640%
120919-SM-16	Yellow metal stair railing	13.690%

Conclusions:

HUD definition of lead based paint is 0.5% or greater. OSHA determines any detectable level of lead as lead-containing. Based on these criteria, the following areas were found to be coated with lead-based paint:

- White concrete beams – **Result: 0.019 %**
- Yellow metal fixed ladder – **Result: 0.141% and 0.015%**
- White metal door frames– **Result: 0.957% and 0.397%**
- Brown metal elevator exterior– **Result: 0.120% and 0.011%**
- Yellow metal stair railing – **Result: 13.640% and 13.690%**

Enclosed in this report are the laboratory analysis, and Chain of Custody.

Should you have any questions, please do not hesitate to call.

Thank you,



Shaenaz Mirmohamed
IH Technician

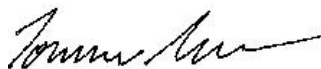

Tommie Green, CIE, CIEC
Industrial Hygienist

Enclosures



White concrete beams



White drywall walls



Yellow concrete walls



Yellow metal fixed ladder



White concrete walls



White metal door frames



Brown metal elevator



Yellow metal stair railing



The Identification Specialists

Analysis Report
prepared for
Phoenix EnviroCorp

Report Date: 12/11/2019

Project Name: 444 Western Boulevard, Jacksonville, NC 28546

Project #: 21-19-290-Pb-I

SanAir ID#: 19062676



1551 Oakbridge Dr. Suite B | Powhatan, Virginia 23139-8061
888.895.1177 | 804.897.1177 | fax: 804.897.0070 | IAQ@SanAir.com | SanAir.com



SanAir ID Number
19062676
FINAL REPORT
12/11/2019 8:55:20 AM

Name: Phoenix EnviroCorp
Address: 4020 Shipyard Blvd
Wilmington, NC 28403
Phone:

Project Number: 21-19-290-Pb-I
P.O. Number:
Project Name: 444 Western Boulevard, Jacksonville, NC
28546
Collected Date: 12/9/2019
Received Date: 12/10/2019 9:50:00 AM

Dear Shaenaz Mirmohamed,

We at SanAir would like to thank you for the work you recently submitted. The 16 sample(s) were received on Tuesday, December 10, 2019 via FedEx. The final report(s) is enclosed for the following sample(s): 120919-SM-01, 120919-SM-02, 120919-SM-03, 120919-SM-04, 120919-SM-05, 120919-SM-06, 120919-SM-07, 120919-SM-08, 120919-SM-09, 120919-SM-10, 120919-SM-11, 120919-SM-12, 120919-SM-13, 120919-SM-14, 120919-SM-15, 120919-SM-16.

These results only pertain to this job and should not be used in the interpretation of any other job. This report is only complete in its entirety. Refer to the listing below of the pages included in a complete final report.

Sincerely,

Abisola Kasali
Metals Laboratory Director
SanAir Technologies Laboratory

Final Report Includes:
- Cover Letter
- Analysis on Test Family AA
- Disclaimers and Additional Information

Sample conditions:
- 16 samples in Good condition.



SanAir ID Number
19062676
 FINAL REPORT
 12/11/2019 8:55:20 AM

Name: Phoenix EnviroCorp
Address: 4020 Shipyard Blvd
 Wilmington, NC 28403
Phone:

Project Number: 21-19-290-Pb-I
P.O. Number:
Project Name: 444 Western Boulevard, Jacksonville, NC
 28546
Collected Date: 12/9/2019
Received Date: 12/10/2019 9:50:00 AM

Analyst: Baird, Marti
 Test Method: SW846/M3050B/7000B

Lead Paint Analysis

PAINT Sample	Description	µg Pb In Sample	Sample Size (grams)	Calculated RL	Sample Results	Sample Results
19062676 - 1	120919-SM-01 LRC-Beams Concrete White Intact	23	0.1208	82.8	191.2 µg/g (ppm)	0.019 % By Weight
19062676 - 2	120919-SM-02 LRC-Beams Concrete White Intact	< 10	0.1119	89.4	<89.4 µg/g (ppm)	<0.009 % By Weight
19062676 - 3	120919-SM-03 LRC-Walls Drywall White Intact	< 10	0.1158	86.4	<86.4 µg/g (ppm)	<0.009 % By Weight
19062676 - 4	120919-SM-04 LRC-Walls Drywall White Intact	< 10	0.1147	87.2	<87.2 µg/g (ppm)	<0.009 % By Weight
19062676 - 5	120919-SM-05 LRC-Walls Concrete Yellow Intact	< 10	0.1295	77.2	<77.2 µg/g (ppm)	<0.008 % By Weight
19062676 - 6	120919-SM-06 LRC-Walls Concrete Yellow Intact	< 10	0.1044	95.8	<95.8 µg/g (ppm)	<0.010 % By Weight
19062676 - 7	120919-SM-07 LRC-Fixed Ladder Metal Yellow Chipping	163	0.1156	86.5	1408 µg/g (ppm)	0.141 % By Weight
19062676 - 8	120919-SM-08 LRC-Fixed Ladder Metal Yellow Chipping	17	0.114	87.7	152.1 µg/g (ppm)	0.015 % By Weight
19062676 - 9	120919-SM-09 LRC-Walls Concrete White Intact	< 10	0.1125	88.9	<88.9 µg/g (ppm)	<0.009 % By Weight
19062676 - 10	120919-SM-10 LRC-Walls Concrete White Intact	< 10	0.1046	95.6	<95.6 µg/g (ppm)	<0.010 % By Weight
19062676 - 11	120919-SM-11 LRC-Door Frames Metal White Intact	1187	0.1241	80.6	9568 µg/g (ppm)	0.957 % By Weight
19062676 - 12	120919-SM-12 LRC-Door Frames Metal White Intact	304	0.0766	130.5	3965 µg/g (ppm)	0.397 % By Weight

Method Reporting Limit <10 µg/0.1 g paint

Signature: *Marti Baird*
 Date: 12/10/2019

Reviewed: *Abir Ghosh*
 Date: 12/10/2019



SanAir ID Number
19062676
 FINAL REPORT
 12/11/2019 8:55:20 AM

Name: Phoenix EnviroCorp
Address: 4020 Shipyard Blvd
 Wilmington, NC 28403
Phone:

Project Number: 21-19-290-Pb-I
P.O. Number:
Project Name: 444 Western Boulevard, Jacksonville, NC
 28546
Collected Date: 12/9/2019
Received Date: 12/10/2019 9:50:00 AM

Analyst: Baird, Marti
 Test Method: SW846/M3050B/7000B

Lead Paint Analysis

PAINT Sample	Description	µg Pb In Sample	Sample Size (grams)	Calculated RL	Sample Results	Sample Results
19062676 - 13	120919-SM-13 LRC-Elevator Metal Brown Intact	164	0.1375	72.7	1195 µg/g (ppm)	0.120 % By Weight
19062676 - 14	120919-SM-14 LRC-Elevator Metal Brown Intact	57	0.501	20	113.9 µg/g (ppm)	0.011 % By Weight
19062676 - 15	120919-SM-15 LRC-Stair Rail Metal Yellow Intact	17600	0.129	77.5	136400 µg/g (ppm)	13.640 % By Weight
19062676 - 16	120919-SM-16 LRC-Stair Rail Metal Yellow Intact	15250	0.1114	89.8	136900 µg/g (ppm)	13.690 % By Weight

Method Reporting Limit <10 µg/0.1 g paint

Signature: *Marti Baird*
 Date: 12/10/2019

Reviewed: *Abisa G. Alkali*
 Date: 12/10/2019

Disclaimer

SanAir Technologies Laboratory, Inc. participates in the Environmental Lead Accreditation Program (ELAP) administered by AIHA-LAP, LLC (Lab ID162952). Refer to our accreditation certificate or www.aihaaccreditedlabs.org for an up to date list of the Fields of Testing for which we are accredited. SanAir also participates in the State of New York's DOH-ELAP (Lab Id 11983), and has met the EPA's NLLAP program standards.

Final reports cannot be reproduced, except in full, without written authorization from SanAir Technologies Laboratory, Inc. SanAir is not responsible for sample collection or interpretation made by others. This report does not constitute endorsement by AIHA-LAP, LLC and/or any other U.S. governmental agencies; and may not be accredited by every local, state or federal regulatory agency. SanAir Technologies Laboratory, Inc only assures the precision and accuracy of the data it generates and assumes no responsibility for errors or biasing that occur during collection prior to SanAir's receipt of the sample(s). SanAir's Method Detection Limits (MDL) and Reporting Limits (RL) have been derived using various materials meeting each accrediting agencies' standards. All quality control results are acceptable unless otherwise noted. Results are not corrected for blanks.

Lead Exposure Limits

Paint

0.5% by weigh HUD definition of lead based paint
1.0 mg/cm²
5000 ppm



**Phoenix
Enviro**

4020 SHIPYARD BLVD
WILMINGTON, NC 28403

CHAIN OF CUSTODY

19062676

LABORATORY TEST REQUEST

CONTACT: Shaenaz Mirmohamed	PHONE: (910) 397-0370	FAX: (910) 313-6094	DATE SHIPPED: 12/9/2019
EMAIL:			

PEC JOB #: 21-19-290-Pb-I	CLIENT'S JOB NAME/#: 444 Western Boulevard, Jacksonville, NC 28546
---------------------------	--

SAMPLE TYPE: Lead Paint Chip (Bulk)	NUMBER OF SAMPLES: 16	TURN AROUND TIME SPECIFIED: _2hr ___ 6hr ___x___24hr ___ 48hr ___ 3-5 day
--	--------------------------	--

SPECIAL INSTRUCTIONS: REPORT RESULTS IN % BY WEIGHT. PLEASE EMAIL RESULTS TO ABOVE LISTED ADDRESS.

SAMPLE #	SAMPLE AREA	SUBSTRATE	COLOR	CONDITION	SAMPLE DATE	LAB ANALYSIS REQUESTED
120919-SM-01	LRC - Beams	Concrete	White	Intact	12/9/2019	AAS
120919-SM-02	LRC - Beams	Concrete	White	Intact	12/9/2019	AAS
120919-SM-03	LRC - Walls	Drywall	White	Intact	12/9/2019	AAS
120919-SM-04	LRC - Walls	Drywall	White	Intact	12/9/2019	AAS
120919-SM-05	LRC - Walls	Concrete	Yellow	Intact	12/9/2019	AAS
120919-SM-06	LRC - Walls	Concrete	Yellow	Intact	12/9/2019	AAS
120919-SM-07	LRC - Fixed ladder	Metal	Yellow	Chipping	12/9/2019	AAS
120919-SM-08	LRC - Fixed ladder	Metal	Yellow	Chipping	12/9/2019	AAS
120919-SM-09	LRC - Walls	Concrete	White	Intact	12/9/2019	AAS
120919-SM-10	LRC - Walls	Concrete	White	Intact	12/9/2019	AAS
120919-SM-11	LRC - Door frames	Metal	White	Intact	12/9/2019	AAS
120919-SM-12	LRC - Door frames	Metal	White	Intact	12/9/2019	AAS
120919-SM-13	LRC - Elevator	Metal	Brown	Intact	12/9/2019	AAS
120919-SM-14	LRC - Elevator	Metal	Brown	Intact	12/9/2019	AAS
120919-SM-15	LRC - Stair rail	Metal	Yellow	Intact	12/9/2019	AAS
120919-SM-16	LRC - Stair rail	Metal	Yellow	Intact	12/9/2019	AAS

CHAIN OF CUSTODY RECORD

DATE	CONDITION OF SAMPLE	SAMPLES RECEIVED BY	SAMPLES RELEASED BY
12/9/2019		SIGNATURE	SIGNATURE <i>Shaenaz Mirmohamed</i>
12/10/19		SIGNATURE (LAB) <i>CS 9:50am</i>	SIGNATURE (LAB)

SECTION 033000 - CAST-IN-PLACE CONCRETE – SEAL SHEET



Divisions, 3 – Section 033000 – Cast-In-Place Concrete
Structural Engineer
Adam Sisk, PE, SE
Woods Engineering, PA
254 N Front St. Suite 201
Wilmington, NC 28401
(910) 343-8007

SECTION 033000 - CAST-IN-PLACE CONCRETE

PART 1 - GENERAL

1.1 RELATED DOCUMENTS

- A. Drawings and general provisions of the Contract, including General and Supplementary Conditions and Division 01 Specification Sections, apply to this Section.

1.2 SUMMARY

- A. Section includes cast-in-place concrete, including formwork, reinforcement, concrete materials, mixture design, placement procedures, and finishes, for the following:
 - 1. Footings.
 - 2. Slabs-on-grade.
- B. Related Sections:
 - 1. Division 31 for drainage fill under slabs-on-grade.
 - 2. Division 32 for concrete pavement and walks.

1.3 DEFINITIONS

- A. Cementitious Materials: Portland cement alone or in combination with one or more of the following: blended hydraulic cement, fly ash and other pozzolans, ground granulated blast-furnace slag, and silica fume; subject to compliance with requirements.

1.4 ACTION SUBMITTALS

- A. Product Data: For each type of product indicated.
- B. Design Mixtures: For each concrete mixture. Submit alternate design mixtures when characteristics of materials, Project conditions, weather, test results, or other circumstances warrant adjustments.
 - 1. Indicate amounts of mixing water to be withheld for later addition at Project site.
- C. Steel Reinforcement Shop Drawings: Placing drawings that detail fabrication, bending, and placement. Include bar sizes, lengths, material, grade, bar schedules, stirrup spacing, bent bar diagrams, bar arrangement, splices and laps, mechanical connections, tie spacing, hoop spacing, and supports for concrete reinforcement.
- D. Construction Joint Layout: Indicate proposed construction joints required to construct the structure.
 - 1. Location of construction joints is subject to approval of the Architect.
- E. Samples: For waterstops and vapor retarder.

1.5 INFORMATIONAL SUBMITTALS

- A. Qualification Data: For Installer and manufacturer.
- B. Welding certificates.
- C. Material Certificates: For each of the following, signed by manufacturers:
 - 1. Cementitious materials.
 - 2. Admixtures.
 - 3. Steel reinforcement and accessories.
 - 4. Curing compounds.
 - 5. Bonding agents.
 - 6. Adhesives.
 - 7. Vapor retarders.
 - 8. Semirigid joint filler.
 - 9. Joint-filler strips.
 - 10. Repair materials.
- D. Material Test Reports: For the following, from a qualified testing agency, indicating compliance with requirements:
 - 1. Aggregates. Include service record data indicating absence of deleterious expansion of concrete due to alkali aggregate reactivity.
- E. Floor surface flatness and levelness measurements indicating compliance with specified tolerances.
- F. Field quality-control reports.
- G. Minutes of preinstallation conference.

1.6 QUALITY ASSURANCE

- A. Installer Qualifications: A qualified installer who employs on Project personnel qualified as ACI-certified Flatwork Technician and Finisher and a supervisor who is an ACI-certified Concrete Flatwork Technician.
- B. Manufacturer Qualifications: A firm experienced in manufacturing ready-mixed concrete products and that complies with ASTM C 94/C 94M requirements for production facilities and equipment.
 - 1. Manufacturer certified according to NRMCA's "Certification of Ready Mixed Concrete Production Facilities."
- C. Source Limitations: Obtain each type or class of cementitious material of the same brand from the same manufacturer's plant, obtain aggregate from single source, and obtain admixtures from single source from single manufacturer.
- D. Welding Qualifications: Qualify procedures and personnel according to AWS D1.4/D 1.4M, "Structural Welding Code - Reinforcing Steel."

- E. ACI Publications: Comply with the following unless modified by requirements in the Contract Documents:
 - 1. ACI 301, "Specifications for Structural Concrete," Sections 1 through 5 and Section 7, "Lightweight Concrete."
 - 2. ACI 117, "Specifications for Tolerances for Concrete Construction and Materials."

- F. Concrete Testing Service: Engage a qualified independent testing agency to perform material evaluation tests and to design concrete mixtures.
 - 1. Testing Agency Qualifications: An independent agency, acceptable to authorities having jurisdiction, qualified according to ASTM C 1077 and ASTM E 329 for testing indicated.
 - a. Personnel conducting field tests shall be qualified as ACI Concrete Field Testing Technician, Grade I, according to ACI CP-1 or an equivalent certification program.
 - b. Personnel performing laboratory tests shall be ACI-certified Concrete Strength Testing Technician and Concrete Laboratory Testing Technician - Grade I. Testing Agency laboratory supervisor shall be an ACI-certified Concrete Laboratory Testing Technician - Grade II.

- G. Preinstallation Conference: Conduct conference at Project site.
 - 1. Before submitting design mixtures, review concrete design mixture and examine procedures for ensuring quality of concrete materials. Require representatives of each entity directly concerned with cast-in-place concrete to attend, including the following:
 - a. Contractor's superintendent.
 - b. Independent testing agency responsible for concrete design mixtures.
 - c. Ready-mix concrete manufacturer.
 - d. Concrete subcontractor.
 - e. Special concrete finish subcontractor.
 - 2. Review testing and inspecting agency procedures for field quality control, concrete finishes and finishing, cold- and hot-weather concreting procedures, curing procedures, construction contraction and isolation joints, and joint-filler strips, vapor-retarder installation, anchor rod and anchorage device installation tolerances, steel reinforcement installation, floor and slab flatness and levelness measurement, concrete repair procedures, and concrete protection.
 - 3. Review floor finishes to be installed and coordinate with curing methods to be used.

1.7 DELIVERY, STORAGE, AND HANDLING

- A. Steel Reinforcement: Deliver, store, and handle steel reinforcement to prevent bending and damage.
- B. Waterstops: Store waterstops under cover to protect from moisture, sunlight, dirt, oil, and other contaminants.

PART 2 - PRODUCTS

2.1 FORM-FACING MATERIALS

- A. Rough-Formed Finished Concrete: Plywood, lumber, metal, or another approved material.

Provide lumber dressed on at least two edges and one side for tight fit.

- B. Chamfer Strips: Wood, metal, PVC, or rubber strips, 3/4 by 3/4 inch, minimum.
- C. Rustication Strips: Wood, metal, PVC, or rubber strips, kerfed for ease of form removal.

2.2 STEEL REINFORCEMENT

- A. Reinforcing Bars: ASTM A 615/A 615M, Grade 60, deformed.
- B. Plain-Steel Welded Wire Reinforcement: ASTM A 185/A 185M, plain, fabricated from as-drawn steel wire into flat sheets.

2.3 REINFORCEMENT ACCESSORIES

- A. Bar Supports: Bolsters, chairs, spacers, and other devices for spacing, supporting, and fastening reinforcing bars and welded wire reinforcement in place. Manufacture bar supports from steel wire, plastic, or precast concrete according to CRSI's "Manual of Standard Practice," of greater compressive strength than concrete and as follows:
 - 1. For concrete surfaces exposed to view where legs of wire bar supports contact forms, use CRSI Class 1 plastic-protected steel wire or CRSI Class 2 stainless-steel bar supports.

2.4 CONCRETE MATERIALS

- A. Cementitious Material: Use the following cementitious materials, of the same type, brand, and source, throughout Project:
 - 1. Portland Cement: ASTM C 150, Type I/II. Supplement with the following:
 - a. Fly Ash: ASTM C 618, Class F.
- B. Normal-Weight Aggregates: ASTM C 33, Class 3S coarse aggregate or better, graded. Provide aggregates from a single source with documented service record data of at least 10 years' satisfactory service in similar applications and service conditions using similar aggregates and cementitious materials.
 - 1. Maximum Coarse-Aggregate Size: 3/4 inch nominal.
 - 2. Fine Aggregate: Free of materials with deleterious reactivity to alkali in cement.
- C. Water: ASTM C 94/C 94M and potable.

2.5 ADMIXTURES

- A. Air-Entraining Admixture: ASTM C 260.
- B. Chemical Admixtures: Provide admixtures certified by manufacturer to be compatible with other admixtures and that will not contribute water-soluble chloride ions exceeding those permitted in hardened concrete. Do not use calcium chloride or admixtures containing calcium chloride.
 - 1. Water-Reducing Admixture: ASTM C 494/C 494M, Type A.
 - 2. Retarding Admixture: ASTM C 494/C 494M, Type B.

3. Water-Reducing and Retarding Admixture: ASTM C 494/C 494M, Type D.
 4. High-Range, Water-Reducing Admixture: ASTM C 494/C 494M, Type F.
 5. High-Range, Water-Reducing and Retarding Admixture: ASTM C 494/C 494M, Type G.
 6. Plasticizing and Retarding Admixture: ASTM C 1017/C 1017M, Type II.
- C. Set-Accelerating Corrosion-Inhibiting Admixture: Commercially formulated, anodic inhibitor or mixed cathodic and anodic inhibitor; capable of forming a protective barrier and minimizing chloride reactions with steel reinforcement in concrete and complying with ASTM C 494/C 494M, Type C.
1. Products: Subject to compliance with requirements, provide one of the following:
 - a. Axim Italcementi Group, Inc.; CATEXOL CN-CI
 - b. BASF Construction Chemicals - Building Systems; Rheocrete CNI
 - c. Euclid Chemical Company (The), an RPM company; ARRIMATECT, EUCON BCN, or EUCON CIA
 - d. Grace Construction Products, W. R. Grace & Co.; DCI
 - e. Sika Corporation; Sika CNI
- D. Synthetic Macro-Fiber: Polyolefin macro-fibers engineered and designed for use in concrete, complying with ASTM C 1116/C 1116M, Type III, 1 to 2-1/4 inches (25 to 57 mm) long.
1. Products: Subject to compliance with requirements, provide one of the following:
 - a. Euclid Chemical Company (The), an RPM company; Tuf-Strand SF.
 - b. FORTA Corporation; FORTA FERRO.
 - c. Grace Construction Products, W. R. Grace & Co.; Strux 90/40.
 - d. Nycon, Inc.; XL.
 - e. Propex Concrete Systems Corp.; Fibermesh 650.
 - f. Sika Corporation; Sika Fiber MS.

2.6 WATERSTOPS

- A. Self-Expanding Butyl Strip Waterstops: Manufactured rectangular or trapezoidal strip, butyl rubber with sodium bentonite or other hydrophilic polymers, for adhesive bonding to concrete, 3/4 by 1 inch.
1. Products: Subject to compliance with requirements, provide one of the following:
 - a. Carlisle Coatings & Waterproofing, Inc.; MiraSTOP.
 - b. CETCO; Volclay Waterstop-RX.
 - c. Concrete Sealants Inc.; Conseal CS-231.
 - d. Greenstreak; Swellstop.
 - e. Henry Company, Sealants Division; Hydro-Flex.
 - f. JP Specialties, Inc.; Earth Shield Type 20.

2.7 VAPOR RETARDERS

- A. Sheet Vapor Retarder: ASTM E 1745, Class A. Include manufacturer's recommended adhesive or pressure-sensitive tape. Maximum perm rating of 0.02.
1. Products: Subject to compliance with requirements, provide one of the following:
 - a. Fortifiber Building Systems Group; Moistop Ultra 15

- b. Grace Construction Products, W. R. Grace & Co.; Florprufe 120
 - c. Insulation Solutions, Inc.; Viper VaporCheck II
 - d. Meadows, W. R., Inc.; Perminator 15 mil
 - e. Raven Industries Inc.; Vapor Block 15
 - f. Reef Industries, Inc.; Griffolyn 15 mil Green
 - g. Stego Industries, LLC; Stego Wrap 15 mil Class A
2. Provide manufacturer's compatible sealer system for penetrations.
- B. Granular Fill: Provide one of the following:
- a. Clean mixture of crushed stone or crushed or uncrushed gravel; ASTM D 448, Size 57, with 100 percent passing a 1-1/2-inch sieve and 0 to 5 percent passing a No. 8 sieve.
 - b. Clean sands with less than 3 percent fines. Materials to be verified by a qualified Geotechnical Engineer.
- C. Fine-Graded Granular Material: Clean mixture of crushed stone, crushed gravel, and manufactured or natural sand; ASTM D 448, Size 10, with 100 percent passing a 3/8-inch sieve, 10 to 30 percent passing a No. 100 sieve, and at least 5 percent passing No. 200 sieve; complying with deleterious substance limits of ASTM C 33 for fine aggregates.

2.8 CURING MATERIALS

- A. Evaporation Retarder: Waterborne, monomolecular film forming, manufactured for application to fresh concrete.
1. Products: Subject to compliance with requirements, provide one of the following:
- a. BASF Construction Chemicals - Building Systems; Confilm
 - b. ChemMasters; SprayFilm
 - c. Conspec by Dayton Superior; Aquafilm
 - d. Dayton Superior Corporation; Sure Film (J-74)
 - e. Euclid Chemical Company (The), an RPM company; Eucobar
 - f. L&M Construction Chemicals, Inc.; E-CON
 - g. Meadows, W. R., Inc.; EVAPRE
 - h. Sika Corporation; SikaFilm
 - i. Symons by Dayton Superior; Finishing Aid
 - j. Unitex; PRO-FILM
- B. Absorptive Cover: AASHTO M 182, Class 2, burlap cloth made from jute or kenaf, weighing approximately 9 oz./sq. yd. when dry.
- C. Moisture-Retaining Cover: ASTM C 171, polyethylene film or white burlap-polyethylene sheet.
- D. Water: Potable.
- E. Clear, Waterborne, Membrane-Forming Curing Compound: ASTM C 309, Type 1, Class B, nondissipating, certified by curing compound manufacturer to not interfere with bonding of floor covering.
1. Products: Subject to compliance with requirements, provide one of the following:

- a. Anti-Hydro International, Inc.; AH Clear Cure WB
- b. BASF Construction Chemicals - Building Systems; Kure-N-Seal WB
- c. ChemMasters; Safe-Cure & Seal 20
- d. Conspec by Dayton Superior; Cure and Seal WB
- e. Cresset Chemical Company; Crete-Trete 309-VOC Cure & Seal
- f. Dayton Superior Corporation; Safe Cure and Seal (J-18)
- g. Euclid Chemical Company (The), an RPM company; Aqua Cure VOX; Clearseal WB 150
- h. L&M Construction Chemicals, Inc.; Dress & Seal WB
- i. Meadows, W. R., Inc.; Vocomp-20
- j. Symons by Dayton Superior; Cure & Seal 18 Percent E

2.9 RELATED MATERIALS

- A. Expansion- and Isolation-Joint-Filler Strips: ASTM D 1751, asphalt-saturated cellulosic fiber.
- B. Semirigid Joint Filler: Two-component, semirigid, 100 percent solids, epoxy resin with a Type A shore durometer hardness of 80 per ASTM D 2240.
- C. Bonding Agent: ASTM C 1059/C 1059M, Type II, non-redispersible, acrylic emulsion or styrene butadiene.
- D. Epoxy Bonding Adhesive: ASTM C 881, two-component epoxy resin, capable of humid curing and bonding to damp surfaces, of class suitable for application temperature and of grade to suit requirements, and as follows:
 - 1. Types IV and V, load bearing, for bonding hardened or freshly mixed concrete to hardened concrete.

2.10 REPAIR MATERIALS

- A. Repair Underlayment: Cement-based, polymer-modified, self-leveling product that can be applied in thicknesses from 1/8 inch and that can be feathered at edges to match adjacent floor elevations.
 - 1. Cement Binder: ASTM C 150, portland cement or hydraulic or blended hydraulic cement as defined in ASTM C 219.
 - 2. Primer: Product of underlayment manufacturer recommended for substrate, conditions, and application.
 - 3. Aggregate: Well-graded, washed gravel, 1/8 to 1/4 inch or coarse sand as recommended by underlayment manufacturer.
 - 4. Compressive Strength: Not less than 4100 psi at 28 days when tested according to ASTM C 109/C 109M.
- B. Repair Overlayment: Cement-based, polymer-modified, self-leveling product that can be applied in thicknesses from 1/4 inch and that can be filled in over a scarified surface to match adjacent floor elevations.
 - 1. Cement Binder: ASTM C 150, portland cement or hydraulic or blended hydraulic cement as defined in ASTM C 219.
 - 2. Primer: Product of topping manufacturer recommended for substrate, conditions, and application.

3. Aggregate: Well-graded, washed gravel, 1/8 to 1/4 inch or coarse sand as recommended by topping manufacturer.
4. Compressive Strength: Not less than 5000 psi at 28 days when tested according to ASTM C 109/C 109M.

2.11 CONCRETE MIXTURES, GENERAL

- A. Prepare design mixtures for each type and strength of concrete, proportioned on the basis of laboratory trial mixture or field test data, or both, according to ACI 301.
 1. Use a qualified independent testing agency for preparing and reporting proposed mixture designs based on laboratory trial mixtures.
- B. Cementitious Materials: Limit percentage, by weight, of cementitious materials other than portland cement in concrete as follows:
 1. Fly Ash: 25 percent.
 2. Combined Fly Ash and Pozzolan: 25 percent.
- C. Limit water-soluble, chloride-ion content in hardened concrete to 0.06 percent by weight of cement.
- D. Admixtures: Use admixtures according to manufacturer's written instructions.
 1. Use water-reducing, high-range water-reducing or plasticizing admixture in concrete, as required, for placement and workability.
 2. Use water-reducing and retarding admixture when required by high temperatures, low humidity, or other adverse placement conditions.
 3. Use water-reducing admixture in pumped concrete, concrete for heavy-use industrial slabs and parking structure slabs, concrete required to be watertight, and concrete with a water-cementitious materials ratio below 0.50.
 4. Use corrosion-inhibiting admixture in concrete mixtures where indicated.

2.12 CONCRETE MIXTURES FOR BUILDING ELEMENTS

- A. Footings: Proportion normal-weight concrete mixture as follows:
 1. Minimum Compressive Strength: 3000 psi at 28 days.
 2. Slump Limit: 4 inches before adding high-range water-reducing admixture or plasticizing admixture, plus or minus 1 inch.
- B. Slabs-on-Grade: Proportion normal-weight concrete mixture as follows:
 1. Minimum Compressive Strength – typical interior slab: 3000 psi at 28 days.
 2. Minimum Compressive Strength – typical exterior slab: 4000 psi (27.6 MPa) at 28 days.
 3. Slump Limit: 4 inches, plus or minus 1 inch.
 4. Air Content: For exterior broom finished concrete only; 6 percent, plus or minus 1.5 percent at point of delivery for 3/4-inch nominal maximum aggregate size.
 5. Air Content: Do not allow air content of trowel-finished floors to exceed 3 percent.

2.13 FABRICATING REINFORCEMENT

- A. Fabricate steel reinforcement according to CRSI's "Manual of Standard Practice."

2.14 CONCRETE MIXING

- A. Ready-Mixed Concrete: Measure, batch, mix, and deliver concrete according to ASTM C 94/C 94M, and furnish batch ticket information.
 - 1. When air temperature is between 85 and 90 deg F, reduce mixing and delivery time from 1-1/2 hours to 75 minutes; when air temperature is above 90 deg F, reduce mixing and delivery time to 60 minutes.

PART 3 - EXECUTION

3.1 FORMWORK

- A. Construct formwork so concrete members and structures are of size, shape, alignment, elevation, and position indicated, within tolerance limits of ACI 117.
- B. Limit concrete surface irregularities, designated by ACI 347 as abrupt or gradual, as follows:
 - 1. Class A, 1/8 inch for smooth-formed finished surfaces.
- C. Construct forms tight enough to prevent loss of concrete mortar.
- D. Fabricate forms for easy removal without hammering or prying against concrete surfaces. Provide crush or wrecking plates where stripping may damage cast concrete surfaces. Provide top forms for inclined surfaces steeper than 1.5 horizontal to 1 vertical.
 - 1. Install keyways, reglets, recesses, and the like, for easy removal.
 - 2. Do not use rust-stained steel form-facing material.
- E. Set edge forms, bulkheads, and intermediate screed strips for slabs to achieve required elevations and slopes in finished concrete surfaces. Provide and secure units to support screed strips; use strike-off templates or compacting-type screeds.
- F. Provide temporary openings for cleanouts and inspection ports where interior area of formwork is inaccessible. Close openings with panels tightly fitted to forms and securely braced to prevent loss of concrete mortar. Locate temporary openings in forms at inconspicuous locations.
- G. Chamfer exterior corners and edges of permanently exposed concrete.
- H. Form openings, chases, offsets, sinkages, keyways, reglets, blocking, screeds, and bulkheads required in the Work. Determine sizes and locations from trades providing such items.
- I. Clean forms and adjacent surfaces to receive concrete. Remove chips, wood, sawdust, dirt, and other debris just before placing concrete.
- J. Retighten forms and bracing before placing concrete, as required, to prevent mortar leaks and maintain proper alignment.

- K. Coat contact surfaces of forms with form-release agent, according to manufacturer's written instructions, before placing reinforcement.

3.2 EMBEDDED ITEMS

- A. Place and secure anchorage devices and other embedded items required for adjoining work that is attached to or supported by cast-in-place concrete. Use setting drawings, templates, diagrams, instructions, and directions furnished with items to be embedded.
 - 1. Install anchor rods, accurately located, to elevations required and complying with tolerances in Section 7.5 of AISC's "Code of Standard Practice for Steel Buildings and Bridges."

3.3 VAPOR RETARDERS

- A. Sheet Vapor Retarders: Place, protect, and repair sheet vapor retarder according to ASTM E 1643 and manufacturer's written instructions.
 - 1. Lap joints 6 inches and seal with manufacturer's recommended tape.
 - 2. Seal around all penetrations with manufacturer's recommended system.

3.4 STEEL REINFORCEMENT

- A. General: Comply with CRSI's "Manual of Standard Practice" for placing reinforcement.
 - 1. Do not cut or puncture vapor retarder. Repair damage and reseal vapor retarder before placing concrete.
- B. Clean reinforcement of loose rust and mill scale, earth, ice, and other foreign materials that would reduce bond to concrete.
- C. Accurately position, support, and secure reinforcement against displacement. Locate and support reinforcement with bar supports to maintain minimum concrete cover. Do not tack weld crossing reinforcing bars.
 - 1. Weld reinforcing bars according to AWS D1.4/D 1.4M, where indicated.
- D. Set wire ties with ends directed into concrete, not toward exposed concrete surfaces.
- E. Install welded wire reinforcement in longest practicable lengths on bar supports spaced to minimize sagging. Lap edges and ends of adjoining sheets at least one mesh spacing. Offset laps of adjoining sheet widths to prevent continuous laps in either direction. Lace overlaps with wire.

3.5 JOINTS

- A. General: Construct joints true to line with faces perpendicular to surface plane of concrete.
- B. Construction Joints: Install so strength and appearance of concrete are not impaired, at locations indicated or as approved by Architect.

1. Place joints perpendicular to main reinforcement. Continue reinforcement across construction joints unless otherwise indicated. Do not continue reinforcement through sides of strip placements of floors and slabs.
 2. Form keyed joints as indicated. Embed keys at least 1-1/2 inches into concrete.
 3. Use a bonding agent at locations where fresh concrete is placed against hardened or partially hardened concrete surfaces.
- C. Contraction Joints in Slabs-on-Grade: Form weakened-plane contraction joints, sectioning concrete into areas as indicated. Construct contraction joints for a depth equal to at least one-fourth of concrete thickness as follows:
1. Grooved Joints: Form contraction joints after initial floating by grooving and finishing each edge of joint to a radius of 1/8 inch. Repeat grooving of contraction joints after applying surface finishes. Eliminate groover tool marks on concrete surfaces.
 2. Sawed Joints: Form contraction joints with power saws equipped with shatterproof abrasive or diamond-rimmed blades. Cut 1/8-inch- wide joints into concrete when cutting action will not tear, abrade, or otherwise damage surface and before concrete develops random contraction cracks.
- D. Isolation Joints in Slabs-on-Grade: After removing formwork, install joint-filler strips at slab junctions with vertical surfaces, such as column pedestals, foundation walls, grade beams, and other locations, as indicated.
1. Extend joint-filler strips full width and depth of joint, terminating flush with finished concrete surface unless otherwise indicated.
 2. Terminate full-width joint-filler strips not less than 1/2 inch or more than 1 inch below finished concrete surface where joint sealants, specified in Section 079200 "Joint Sealants," are indicated.
 3. Install joint-filler strips in lengths as long as practicable. Where more than one length is required, lace or clip sections together.

3.6 CONCRETE PLACEMENT

- A. Before placing concrete, verify that installation of formwork, reinforcement, and embedded items is complete and that required inspections have been performed.
- B. Do not add water to concrete during delivery, at Project site, or during placement unless approved by Architect.
- C. Before test sampling and placing concrete, water may be added at Project site, subject to limitations of ACI 301.
 1. Do not add water to concrete after adding high-range water-reducing admixtures to mixture.
- D. Deposit concrete continuously in one layer or in horizontal layers of such thickness that no new concrete will be placed on concrete that has hardened enough to cause seams or planes of weakness. If a section cannot be placed continuously, provide construction joints as indicated. Deposit concrete to avoid segregation.
 1. Deposit concrete in horizontal layers of depth to not exceed formwork design pressures and in a manner to avoid inclined construction joints.
 2. Consolidate placed concrete with mechanical vibrating equipment according to ACI 301.

3. Do not use vibrators to transport concrete inside forms. Insert and withdraw vibrators vertically at uniformly spaced locations to rapidly penetrate placed layer and at least 6 inches into preceding layer. Do not insert vibrators into lower layers of concrete that have begun to lose plasticity. At each insertion, limit duration of vibration to time necessary to consolidate concrete and complete embedment of reinforcement and other embedded items without causing mixture constituents to segregate.
- E. Deposit and consolidate concrete for floors and slabs in a continuous operation, within limits of construction joints, until placement of a panel or section is complete.
1. Consolidate concrete during placement operations so concrete is thoroughly worked around reinforcement and other embedded items and into corners.
 2. Maintain reinforcement in position on chairs during concrete placement.
 3. Screed slab surfaces with a straightedge and strike off to correct elevations.
 4. Slope surfaces uniformly to drains where required.
 5. Begin initial floating using bull floats or darbies to form a uniform and open-textured surface plane, before excess bleedwater appears on the surface. Do not further disturb slab surfaces before starting finishing operations.
- F. Cold-Weather Placement: Comply with ACI 306.1 and as follows. Protect concrete work from physical damage or reduced strength that could be caused by frost, freezing actions, or low temperatures.
1. When average high and low temperature is expected to fall below 40 deg F for three successive days, maintain delivered concrete mixture temperature within the temperature range required by ACI 301.
 2. Do not use frozen materials or materials containing ice or snow. Do not place concrete on frozen subgrade or on subgrade containing frozen materials.
 3. Do not use calcium chloride, salt, or other materials containing antifreeze agents or chemical accelerators unless otherwise specified and approved in mixture designs.
- G. Hot-Weather Placement: Comply with ACI 301 and as follows:
1. Maintain concrete temperature below 90 deg F at time of placement. Chilled mixing water or chopped ice may be used to control temperature, provided water equivalent of ice is calculated to total amount of mixing water. Using liquid nitrogen to cool concrete is Contractor's option.
 2. Fog-spray forms, steel reinforcement, and subgrade just before placing concrete. Keep subgrade uniformly moist without standing water, soft spots, or dry areas.

3.7 FINISHING FORMED SURFACES

- A. Rough-Formed Finish: As-cast concrete texture imparted by form-facing material with tie holes and defects repaired and patched. Remove fins and other projections that exceed specified limits on formed-surface irregularities.
1. Apply to concrete surfaces not exposed to public view.
- B. Smooth-Formed Finish: As-cast concrete texture imparted by form-facing material, arranged in an orderly and symmetrical manner with a minimum of seams. Repair and patch tie holes and defects. Remove fins and other projections that exceed specified limits on formed-surface irregularities.

1. Apply to concrete surfaces exposed to public view or to be covered with a coating or covering material applied directly to concrete.
- C. Related Unformed Surfaces: At tops of walls, horizontal offsets, and similar unformed surfaces adjacent to formed surfaces, strike off smooth and finish with a texture matching adjacent formed surfaces. Continue final surface treatment of formed surfaces uniformly across adjacent unformed surfaces unless otherwise indicated.

3.8 FINISHING FLOORS AND SLABS

- A. General: Comply with ACI 302.1R recommendations for screeding, restraighening, and finishing operations for concrete surfaces. Do not wet concrete surfaces.
- B. Scratch Finish: While still plastic, texture concrete surface that has been screeded and bull-floated or darbied. Use stiff brushes, brooms, or rakes to produce a profile amplitude of 1/4 inch in one direction.
 1. Apply scratch finish to surfaces indicated and to receive mortar setting beds for bonded cementitious floor finishes.
- C. Float Finish: Consolidate surface with power-driven floats or by hand floating if area is small or inaccessible to power driven floats. Restraighten, cut down high spots, and fill low spots. Repeat float passes and restraighening until surface is left with a uniform, smooth, granular texture.
 1. Apply float finish to surfaces indicated to receive trowel finish.
- D. Trowel Finish: After applying float finish, apply first troweling and consolidate concrete by hand or power-driven trowel. Continue troweling passes and restraighten until surface is free of trowel marks and uniform in texture and appearance. Grind smooth any surface defects that would telegraph through applied coatings or floor coverings.
 1. Apply a trowel finish to surfaces exposed to view or to be covered with resilient flooring, carpet, ceramic or quarry tile set over a cleavage membrane, paint, or another thin-film-finish coating system.
 2. Finish surfaces to the following tolerances, according to ASTM E 1155, for a randomly trafficked floor surface:
 - a. Specified overall values of flatness, F(F) 25; and of levelness, F(L) 20; with minimum local values of flatness, F(F) 17; and of levelness, F(L) 15.
- E. Trowel and Fine-Broom Finish: Apply a first trowel finish to surfaces where ceramic or quarry tile is to be installed by either thickset or thin-set method. While concrete is still plastic, slightly scarify surface with a fine broom.
 1. Comply with flatness and levelness tolerances for trowel-finished floor surfaces.
- F. Broom Finish: Apply a broom finish to exterior concrete platforms, steps, ramps, and elsewhere as indicated.
 1. Immediately after float finishing, slightly roughen trafficked surface by brooming with fiber-bristle broom perpendicular to main traffic route. Coordinate required final finish with Architect before application.

3.9 MISCELLANEOUS CONCRETE ITEMS

- A. Filling In: Fill in holes and openings left in concrete structures after work of other trades is in place unless otherwise indicated. Mix, place, and cure concrete, as specified, to blend with in-place construction. Provide other miscellaneous concrete filling indicated or required to complete the Work.
- B. Curbs: Provide monolithic finish to interior curbs by stripping forms while concrete is still green and by steel-troweling surfaces to a hard, dense finish with corners, intersections, and terminations slightly rounded.
- C. Equipment Bases and Foundations: Provide machine and equipment bases and foundations as shown on Drawings. Set anchor bolts for machines and equipment at correct elevations, complying with diagrams or templates from manufacturer furnishing machines and equipment.
- D. Steel Pan Stairs: Provide concrete fill for steel pan stair treads, landings, and associated items. Cast-in inserts and accessories as shown on Drawings. Screed, tamp, and trowel finish concrete surfaces.

3.10 CONCRETE PROTECTING AND CURING

- A. General: Protect freshly placed concrete from premature drying and excessive cold or hot temperatures. Comply with ACI 306.1 for cold-weather protection and ACI 301 for hot-weather protection during curing.
- B. Evaporation Retarder: Apply evaporation retarder to unformed concrete surfaces if hot, dry, or windy conditions cause moisture loss approaching 0.2 lb/sq. ft. x h before and during finishing operations. Apply according to manufacturer's written instructions after placing, screeding, and bull floating or darbying concrete, but before float finishing.
- C. Formed Surfaces: Cure formed concrete surfaces, including underside of beams, supported slabs, and other similar surfaces. If forms remain during curing period, moist cure after loosening forms. If removing forms before end of curing period, continue curing for the remainder of the curing period.
- D. Unformed Surfaces: Begin curing immediately after finishing concrete. Cure unformed surfaces, including floors and slabs, concrete floor toppings, and other surfaces.
- E. Cure concrete according to ACI 308.1, by one or a combination of the following methods:
 - 1. Moisture Curing: Keep surfaces continuously moist for not less than seven days with the following materials:
 - a. Water.
 - b. Continuous water-fog spray.
 - c. Absorptive cover, water saturated, and kept continuously wet. Cover concrete surfaces and edges with 12-inch lap over adjacent absorptive covers.
 - 2. Moisture-Retaining-Cover Curing: Cover concrete surfaces with moisture-retaining cover for curing concrete, placed in widest practicable width, with sides and ends lapped at least 12 inches, and sealed by waterproof tape or adhesive. Cure for not less than seven days.

Immediately repair any holes or tears during curing period using cover material and waterproof tape.

- a. Moisture cure or use moisture-retaining covers to cure concrete surfaces to receive floor coverings.
 - b. Moisture cure or use moisture-retaining covers to cure concrete surfaces to receive penetrating liquid floor treatments.
 - c. Cure concrete surfaces to receive floor coverings with either a moisture-retaining cover or a curing compound that the manufacturer certifies will not interfere with bonding of floor covering used on Project.
3. Curing Compound: Apply uniformly in continuous operation by power spray or roller according to manufacturer's written instructions. Recoat areas subjected to heavy rainfall within three hours after initial application. Maintain continuity of coating and repair damage during curing period.
- a. Removal: After curing period has elapsed, remove curing compound without damaging concrete surfaces by method recommended by curing compound manufacturer unless manufacturer certifies curing compound will not interfere with bonding of floor covering used on Project.

3.11 JOINT FILLING

- A. Prepare, clean, and install joint filler according to manufacturer's written instructions.
 1. Defer joint filling until concrete has aged at least one month. Do not fill joints until construction traffic has permanently ceased.
- B. Remove dirt, debris, saw cuttings, curing compounds, and sealers from joints; leave contact faces of joint clean and dry.
- C. Install semirigid joint filler full depth in saw-cut joints and at least 2 inches deep in formed joints. Overfill joint and trim joint filler flush with top of joint after hardening.

3.12 CONCRETE SURFACE REPAIRS

- A. Defective Concrete: Repair and patch defective areas when approved by Architect. Remove and replace concrete that cannot be repaired and patched to Architect's approval.
- B. Patching Mortar: Mix dry-pack patching mortar, consisting of one part portland cement to two and one-half parts fine aggregate passing a No. 16 sieve, using only enough water for handling and placing.
- C. Repairing Formed Surfaces: Surface defects include color and texture irregularities, cracks, spalls, air bubbles, honeycombs, rock pockets, fins and other projections on the surface, and stains and other discolorations that cannot be removed by cleaning.
 1. Immediately after form removal, cut out honeycombs, rock pockets, and voids more than 1/2 inch in any dimension to solid concrete. Limit cut depth to 3/4 inch. Make edges of cuts perpendicular to concrete surface. Clean, dampen with water, and brush-coat holes and voids with bonding agent. Fill and compact with patching mortar before bonding agent has dried. Fill form-tie voids with patching mortar or cone plugs secured in place with bonding agent.

2. Repair defects on surfaces exposed to view by blending white portland cement and standard portland cement so that, when dry, patching mortar will match surrounding color. Patch a test area at inconspicuous locations to verify mixture and color match before proceeding with patching. Compact mortar in place and strike off slightly higher than surrounding surface.
 3. Repair defects on concealed formed surfaces that affect concrete's durability and structural performance as determined by Architect.
- D. Repairing Unformed Surfaces: Test unformed surfaces, such as floors and slabs, for finish and verify surface tolerances specified for each surface. Correct low and high areas. Test surfaces sloped to drain for trueness of slope and smoothness; use a sloped template.
1. Repair finished surfaces containing defects. Surface defects include spalls, popouts, honeycombs, rock pockets, crazing and cracks in excess of 0.01 inch wide or that penetrate to reinforcement or completely through unreinforced sections regardless of width, and other objectionable conditions.
 2. After concrete has cured at least 14 days, correct high areas by grinding.
 3. Correct localized low areas during or immediately after completing surface finishing operations by cutting out low areas and replacing with patching mortar. Finish repaired areas to blend into adjacent concrete.
 4. Correct other low areas scheduled to receive floor coverings with a repair underlayment. Prepare, mix, and apply repair underlayment and primer according to manufacturer's written instructions to produce a smooth, uniform, plane, and level surface. Feather edges to match adjacent floor elevations.
 5. Correct other low areas scheduled to remain exposed with a repair topping. Cut out low areas to ensure a minimum repair topping depth of 1/4 inch to match adjacent floor elevations. Prepare, mix, and apply repair topping and primer according to manufacturer's written instructions to produce a smooth, uniform, plane, and level surface.
 6. Repair defective areas, except random cracks and single holes 1 inch or less in diameter, by cutting out and replacing with fresh concrete. Remove defective areas with clean, square cuts and expose steel reinforcement with at least a 3/4-inch clearance all around. Dampen concrete surfaces in contact with patching concrete and apply bonding agent. Mix patching concrete of same materials and mixture as original concrete except without coarse aggregate. Place, compact, and finish to blend with adjacent finished concrete. Cure in same manner as adjacent concrete.
 7. Repair random cracks and single holes 1 inch or less in diameter with patching mortar. Groove top of cracks and cut out holes to sound concrete and clean off dust, dirt, and loose particles. Dampen cleaned concrete surfaces and apply bonding agent. Place patching mortar before bonding agent has dried. Compact patching mortar and finish to match adjacent concrete. Keep patched area continuously moist for at least 72 hours.
- E. Perform structural repairs of concrete, subject to Architect's approval, using epoxy adhesive and patching mortar.
- F. Repair materials and installation not specified above may be used, subject to Architect's approval.

3.13 FIELD QUALITY CONTROL

- A. Testing and Inspecting: Owner will engage a qualified testing and inspecting agency to perform field tests and inspections and prepare test reports.

B. Inspections:

1. Steel reinforcement placement.
2. Steel reinforcement welding.
3. Headed bolts and studs.
4. Verification of use of required design mixture.
5. Concrete placement, including conveying and depositing.
6. Curing procedures and maintenance of curing temperature.
7. Verification of concrete strength before removal of shores and forms from beams and slabs.

C. Concrete Tests: Testing of composite samples of fresh concrete obtained according to ASTM C 172 shall be performed according to the following requirements:

1. Testing Frequency: Samples for strength tests of each class of concrete placed each day shall be taken not less than once a day, nor less than once for each 150 cu. yd. (114 cu. m) of concrete, nor less than once for each 5,000 sq. ft. of surface area for slabs or walls.
2. Slump: ASTM C 143/C 143M; one test at point of placement for each composite sample, but not less than one test for each day's pour of each concrete mixture. Perform additional tests when concrete consistency appears to change.
3. Air Content: ASTM C 231, pressure method, for normal-weight concrete; one test for each composite sample, but not less than one test for each day's pour of each concrete mixture.
4. Concrete Temperature: ASTM C 1064/C 1064M; one test hourly when air temperature is 40 deg F and below and when 80 deg F and above, and one test for each composite sample.
5. Unit Weight: ASTM C 567, fresh unit weight of structural lightweight concrete; one test for each composite sample, but not less than one test for each day's pour of each concrete mixture.
6. Compression Test Specimens: ASTM C 31/C 31M.
 - a. Cast and laboratory cure two sets of two standard cylinder specimens for each composite sample.
7. Strength of each concrete mixture will be satisfactory if every average of any three consecutive compressive-strength tests equals or exceeds specified compressive strength and no compressive-strength test value falls below specified compressive strength by more than 500 psi.
8. Test results shall be reported in writing to Architect, concrete manufacturer, and Contractor within 48 hours of testing. Reports of compressive-strength tests shall contain Project identification name and number, date of concrete placement, name of concrete testing and inspecting agency, location of concrete batch in Work, design compressive strength at 28 days, concrete mixture proportions and materials, compressive breaking strength, and type of break for both 7- and 28-day tests.
9. Nondestructive Testing: Impact hammer, sonoscope, or other nondestructive device may be permitted by Architect but will not be used as sole basis for approval or rejection of concrete.
10. Additional Tests: Testing and inspecting agency shall make additional tests of concrete when test results indicate that slump, air entrainment, compressive strengths, or other requirements have not been met, as directed by Architect. Testing and inspecting agency may conduct tests to determine adequacy of concrete by cored cylinders complying with ASTM C 42/C 42M or by other methods as directed by Architect.
11. Additional testing and inspecting, at Contractor's expense, will be performed to determine compliance of replaced or additional work with specified requirements.

12. Correct deficiencies in the Work that test reports and inspections indicate do not comply with the Contract Documents.
- D. Measure floor and slab flatness and levelness according to ASTM E 1155 within 48 hours of finishing.

END OF SECTION 033000

SECTION 033010 – VAPOR RETARDER FOR CAST-IN-PLACE CONCRETE

PART 1 - GENERAL

1.1 SUMMARY

- A. Section includes vapor retarders installed under cast-in-place concrete.
 - 1. Vapor Retarder, Seam Tape & Accessories for installation under concrete slabs.

1.2 ACTION SUBMITTALS

- A. Product Data: For each type of product indicated.

1.3 INFORMATIONAL SUBMITTALS

- A. Material test reports.

1.4 QUALITY ASSURANCE

- A. Preinstallation Conference: Conduct conference at Project site.
 - 1. Manufacturer's samples, literature.
 - 2. Manufacturer's installation instructions for placement, seaming and penetration repair instructions.

PART 2 - PRODUCTS

2.1 VAPOR RETARDERS

- A. Sheet Vapor Retarder: Polyethylene sheet, ASTM D 4397, not less than 15 mil thick.
- B. Vapor Barrier System: Provide vapor barrier cover over prepared base material where indicated below slabs on grade. Use only materials that are resistant to deterioration and puncture when tested as follows:
 - 1. Material must meet ASTM E-1745, Class A and permeance of no more than 0.01 perms.
- C. Basis of Design Product: Subject to compliance with requirements provide Stego Wrap vapor Barrier (15 mil).
 - 1. Perminator 15 mil, W.R. Meadows
 - 2. Griffolyn 15, Reef Industries
 - 3. Barrier-Bac #VB-350.

- a. Provide manufacturer's recommended tapes and sealing compounds.

2.2 ACCESSORIES

A. Seam Tape

1. Tape manufactured and/or supplied by the approved manufacturers listed in section 2.1 Materials:
 - a. Water Vapor Permeance ASTM E 96B <0.01 Perms.

B. Pipe Boots

1. Construct Pipe Boots and seal penetrations from Vapor Retarder material and pressure sensitive tape per manufacturer's instructions or from liquid vapor retarder membrane.

C. Liquid Vapor Retarder Membrane

1. Mastic must have the following qualities:
 - a. Water Vapor Transmission ASTM E 96 — 0.3 perms or lower.
 - b. Basis of Design: Subject to compliance with requirements, provide Stego Mastic.

PART 3 - EXECUTION

3.1 PREPARATION

- A. Ensure that base material is approved by Architect or Geotechnical Engineer.
 1. Level and compact base material.

3.2 INSTALLATION

- A. Install vapor retarder in accordance with manufacturer's instructions and ASTM E 1643:
 1. Following leveling and tamping of granular base for slabs on grade, place vapor retarder sheeting with longest dimension parallel with direction of pour and face laps away from the expected direction of the placement whenever possible.
 2. Extend vapor retarder to the perimeter of the slab. If practicable, terminate it at the top of the slab, otherwise (a) at a point acceptable to the structural engineer or (b) where obstructed by impediments, such as dowels, waterstops, or any other site condition requiring early termination of the vapor retarder. At the point of termination, seal vapor retarder to the foundation wall, grade beam or slab itself.
 3. Overlap joints 6 inches and seal with manufacturer's tape.
 4. Seal all penetrations (including pipes) per manufacturer's instructions.
 5. No penetration of the vapor retarder is allowed except for reinforcing steel and permanent utilities.

6. Repair damaged areas by cutting patches of vapor retarder, overlapping damaged area 6 inches and taping all sides with tape.
7. Avoid the use of non-permanent stakes driven through vapor retarder.
8. If non-permanent stakes are driven through vapor retarder, repair as recommended by vapor retarder manufacturer.

3.3 INSPECTION

- A. G.C. shall notify Architect when vapor retarder installation is complete.
- B. Contractor shall provide written confirmation to the Architect that the installation is in compliance with the vapor retarder manufacturer's installation instructions and guidelines.

END OF SECTION 033010

SECTION 034910 - GLASS FIBER REINFORCED CONCRETE

PART 1 - GENERAL

1.1 RELATED DOCUMENTS

- A. Drawings and general provisions of the Contract, including General and Supplementary Conditions and Division 1 Specification Sections, apply to this Section.

1.2 SUMMARY

- A. This Section includes glass fiber reinforced concrete (GFRC) trim units consisting of GFRC panel frames, anchors, and connection hardware.
 - 1. GFRC columns include shapes as indicated.
- B. Related Sections include the following:
 - 1. Division 3 Section "Cast-in-Place Concrete" for placing connection anchors in concrete.
 - 2. Division 5 Section "Structural Steel" for connection attachment to structural steel framing.
 - 3. Division 7 Section "Joint Sealants" for elastomeric joint sealants and sealant backings.

1.3 DEFINITIONS

- A. Design Reference Sample: Sample of approved GFRC color, finish, and texture; preapproved by Architect.

1.4 PERFORMANCE REQUIREMENTS

- A. Structural Performance: Provide GFRC panels, including panel frames, anchors, and connections, capable of withstanding the following design loads as well as the effects of thermal- and moisture-induced volume changes, according to load factors and combinations established in PCI MNL 128, "Recommended Practice for Glass Fiber Reinforced Concrete Panels."
 - 1. Design panels to provide for loading values determined by the Structural Engineer of record and indicated in the Contract Documents. Loads include dead load, live load, wind loads, and earthquake.
 - 2. Deflection: Design panel frames to withstand design loads without lateral deflections greater than 1/360 of wall span.
 - 3. Thermal Movements: Provide for thermal movements resulting from annual ambient temperature changes of 120 deg. F.

4. Design panel frames and connections to accommodate deflections and other building movements.
5. Design panel frames to transfer window loads to building structure.

1.5 SUBMITTALS

- A. Product Data: For each type of product indicated. Include GFRC design mixes.
- B. Shop Drawings: Show fabrication and installation details for GFRC column covers, including the following:
 1. Structural analysis data signed and sealed by the qualified professional engineer responsible for their preparation.
 2. Panel elevations, sections, and dimensions.
 3. Thickness of facing mix, GFRC backing, and bonding pads for typical panels.
 4. Finishes.
 5. Joint and connection details.
 6. Erection details.
 7. Panel frame details for typical panels, including sizes, spacings, thickness, and yield strength of various members.
 8. Location and details of connection hardware attached to structure.
 9. Size, location, and details of flex, gravity, and seismic anchors for typical panels.
 10. Other items sprayed into panels.
 11. Erection sequence for special conditions.
 12. Relationship to adjacent materials.
 13. Description of loose, cast-in, and field hardware.
- C. Samples: Representative of finished exposed face of GFRC showing the full range of colors and textures expected, 16 by 16 inches and of actual thickness.
- D. Welding certificates.
- E. Steel Sheet Certification. For steel sheet used in cold-formed steel panel framing.
- F. Qualification Data: For GFRC manufacturer, including proof of current PCI Plant Certification.
- G. Source Quality-Control Program: For GFRC manufacturer.
- H. Source Quality-Control Test Reports: For GFRC, inserts, and anchors.
- I. Research/Evaluation Reports: For GFRC.

1.6 QUALITY ASSURANCE

- A. Manufacturer Qualifications: A qualified manufacturer who participates in PCI's Plant Certification Program and is designated a PCI-Certified Plant for Group G - Glass Fiber Reinforced Concrete.

1. Manufacturer's responsibility includes fabricating and installing GFRC panels and providing professional engineering services needed to assume engineering responsibility for GFRC panels.
 2. Engineering responsibility includes preparation of Shop Drawings and comprehensive engineering analysis, based on GFRC production test values, by a qualified professional engineer experienced in GFRC design.
- B. Steel Sheet Certifications: Obtain mill certificates, signed by manufacturers of steel sheet, or test reports from a qualified testing agency indicating that steel sheet used in cold-formed metal panel framing complies with requirements including uncoated steel thickness, yield strength, tensile strength, total elongation, chemical requirements, and galvanized-coating thickness.
- C. Source Limitations: Obtain GFRC panels through one source from a single manufacturer.
- D. Welding: Qualify procedures and personnel according to AWS D1.1, "Structural Welding Code - Steel," and AWS D1.3, "Structural Welding Code - Sheet Steel."
- E. PCI Manuals: Comply with requirements and recommendations in the following PCI manuals unless more stringent requirements are indicated:
1. PCI MNL 128, "Recommended Practice for Glass Fiber Reinforced Concrete Panels."
 2. PCI MNL 130, "Manual for Quality Control for Plants and Production of Glass Fiber Reinforced Concrete Products."
- F. AISI Specifications: Comply with AISI's "Specification for the Design of Cold-Formed Steel Structural Members."
- G. Mockups: Build mockups to demonstrate aesthetic effects and set quality standards for fabrication and installation.
1. Build mockup of typical wall area as shown on Drawings as part of building.
 2. In addition to GFRC panels, mockups include unit masonry, aluminum windows, joint sealants, metal flashings and copings.
 3. Approved mockups may become part of the completed Work if undamaged at time of Final Acceptance.
- H. Preinstallation Conference: Conduct conference at Project site to comply with requirements in Division 1 Section "Project Management and Coordination."

1.7 DELIVERY, STORAGE, AND HANDLING

- A. Handle and transport GFRC panels to avoid damage.
1. Place nonstaining resilient spacers between panels.
 2. Support panels during shipment on nonstaining material.
 3. Protect panels from dirt and damage during handling and transport.
- B. Store GFRC panels to protect from contact with soil, staining, and physical damage.

1. Store panels with nonstaining resilient supports in same positions as when transported.
2. Store panels on firm, level, and smooth surfaces.
3. Place stored panels so identification marks are clearly visible.

PART 2 - PRODUCTS

2.1 MOLD MATERIALS

- A. Molds: Rigid, dimensionally stable, nonabsorptive material, warp and buckle free, that will provide continuous and true GFRC surfaces; nonreactive with GFRC and capable of producing required finish surfaces.
 1. Mold-Release Agent: Commercially produced liquid-release agent that will not bond with, stain, or adversely affect GFRC surfaces and will not impair subsequent surface or joint treatments of GFRC.

2.2 MANUFACTURERS

- A. Basis of Design: Provide products manufactured by **Stromberg Architectural Products**. Subject to compliance with requirements, provide products by, but not necessarily limited to, one of the following:
 1. GFRC Cladding Systems LLC
 2. Melton Classics
 3. First Class Building Products

2.3 GFRC MATERIALS

- A. Portland Cement: ASTM C 150, Type I.
 1. For surfaces exposed to view in finished structure, use natural color except white if needed to match an approved sample. Cement of same type, brand, and source throughout GFRC production.
 2. Metakaolin: ASTM C 618, Class N.
- B. Glass Fibers: Alkali resistant, with a minimum zirconia content of 16 percent, 1 to 2 inches long, specifically produced for use in GFRC, and complying with PCI MNL 130.
- C. Sand: Washed and dried silica, complying with composition requirements of ASTM C 144; passing No. 20 sieve with a maximum of 2 percent passing No. 100 sieve.
- D. Water: Potable; free from deleterious material that may affect color stability, setting, or strength of GFRC and complying with chemical limits of PCI MNL 130.
- E. Polymer-Curing Admixture: Acrylic thermoplastic copolymer dispersion complying with PCI MNL 130.

- F. Air-Entraining Admixture: ASTM C 260, containing not more than 0.1 percent chloride ions.
- G. Chemical Admixtures: ASTM C 494/C 494M, containing not more than 0.1 percent chloride ions.

2.4 ANCHORS, CONNECTORS, AND MISCELLANEOUS MATERIALS

- A. Carbon-Steel Shapes and Plates: ASTM A 36/A 36M. Finish steel shapes and plates less than 3/16 inch thick as follows:
 - 1. Finish: Zinc coated by hot-dip process according to ASTM A 123/A 123M, after fabrication, or ASTM A 153/A 153M, as applicable.
- B. Carbon-Steel Bars: ASTM A 108, AISI Grade 1018. Finish steel bars less than 3/16 inch thick as follows:
 - 1. Finish: Zinc coated by hot-dip process according to ASTM A 123/A 123M, after fabrication, or ASTM A 153/A 153M, as applicable.
- C. Malleable-Iron Castings: ASTM A 47/ A 47M Grade 32510.
- D. Carbon-Steel Castings: ASTM A 27/A 27M, Grade 60-30.
- E. Bolts: ASTM A 307 or ASTM A 325.
- F. Reglets: Fabricator's standard, stainless steel.

2.5 PANEL FRAME MATERIALS

- A. Cold-Formed Steel Framing: Manufacturer's standard C-shaped steel studs, complying with AISI's "Specification for the Design of Cold-Formed Steel Structural Members," minimum uncoated steel thickness of 0.0538 inch, with stiffened flanges, U-shaped steel track, and of the following steel sheet:
 - 1. Metallic-Coated Steel Sheet: ASTM A 653/A 653M, structural-steel sheet, G60 zinc coating, of grade required by structural performance of framing.
- B. Hollow Structural Sections: Steel tubing, ASTM A 500, Grade B, or ASTM A 513. Finish hollow structural sections with wall thickness less than 3/16 inch as follows:
 - 1. Organic Zinc-Rich Primer: SSPC-Paint 20 on surfaces prepared to comply with SSPC-SP 6/NACE No. 3, "Commercial Blast Cleaning."
- C. Steel Channels and Angles: ASTM A 36/A 36M, finished as follows:
 - 1. Organic Zinc-Rich Primer: SSPC-Paint 20 on surfaces prepared to comply with SSPC-SP 6/NACE No. 3, "Commercial Blast Cleaning."

2.6 GFRC MIXES

- A. Backing Mix: Proportion backing mix of portland cement, glass fibers, sand, and admixtures to comply with design requirements. Provide nominal glass-fiber content of not less than 5 percent by weight of total mix.
- B. Face Mix: Proportion face mix of portland cement, sand, facing aggregates, and admixtures to comply with design requirements.
- C. Polymer-Curing Admixture: 6 to 7 percent by weight of polymer-curing admixture solids to dry portland cement.
- D. Air Content: 8 to 10 percent; ASTM C 185.

2.7 PANEL FRAME FABRICATION

- A. Fabricate panel frames and accessories plumb, square, true to line, and with components securely fastened, according to Shop Drawings and requirements in this Section.
 - 1. Fabricate panel frames using jigs or templates.
 - 2. Cut cold-formed metal framing members by sawing or shearing; do not torch cut.
 - 3. Fasten cold-formed metal framing members by welding. Comply with AWS D1.3 requirements and procedures for welding, appearance and quality of welds, and methods used in correcting welding work.
 - 4. Fasten framing members of hollow structural sections, steel channels, or steel angles by welding. Comply with AWS D1.1 requirements and procedures for welding, appearance and quality of welds, and methods used in correcting welding work.
 - 5. Weld flex, gravity, and seismic anchors to panel frames.
- B. Reinforce, stiffen, and brace framing assemblies, if necessary, to withstand handling, delivery, and erection stresses. Lift fabricated assemblies in a manner that prevents damage or significant distortion.
- C. Galvanizing Repair: Touch up accessible damaged galvanized surfaces according to ASTM A 780.
- D. Painting Repair: Touch up accessible damaged painted surfaces using same primer.

2.8 MOLD FABRICATION

- A. Construct molds that will result in finished GFRC complying with profiles, dimensions, and tolerances indicated, without damaging GFRC during stripping. Construct molds to prevent water leakage and loss of cement paste.
 - 1. Coat contact surfaces of molds with form-release agent.
- B. Place form liners accurately to provide finished surface texture indicated. Provide solid backing and supports to maintain stability of liners during GFRC application. Coat form liner with form-release agent.

2.9 GFRC FABRICATION

- A. Proportioning and Mixing: For backing mix, meter sand/cement slurry and glass fibers to spray head at rates to achieve design mix proportions and glass-fiber content according to PCI MNL 130 procedures.
- B. Spray Application: Comply with general procedures as follows:
 - 1. Spray or place face mix in thickness indicated on Shop Drawings.
 - 2. Proceed with spraying backing mix before face mix has set, using procedures that produce a uniform thickness and even distribution of glass fibers and matrix.
 - 3. Consolidate backing mix by rolling or other technique to achieve complete encapsulation of glass fibers and compaction.
 - 4. Measure thickness with a pin gage or other acceptable method at least once for each 5 sq. ft. of panel surface. Take not less than six measurements per panel.
- C. Hand form and consolidate intricate details, incorporate formers or infill materials, and over spray before material reaches initial set to ensure complete bonding.
- D. Attach panel frame to GFRC before initial set of GFRC backing, maintaining a minimum clearance of 1/2 inch from GFRC backing, and without anchors protruding into GFRC backing.
- E. Build up homogeneous GFRC bonding pads over anchor feet, maintaining a minimum thickness of 1/2 inch over tops of anchor feet, before initial set of GFRC backing.
- F. Inserts and Embedments: Build up homogeneous GFRC bosses or bonding pads over inserts and embedments to provide sufficient anchorage and embedment to comply with design requirements.
- G. Curing: Employ initial curing method that will ensure sufficient strength for removing units from mold.
 - 1. After initial curing, remove panel from mold and place in a controlled curing environment.
 - 2. Keep GFRC panels continuously moist for a minimum of seven days unless polymer-curing admixture was used. Maintain temperature between 60 and 120 deg F during this period.
- H. Panel Identification: Mark each GFRC panel to correspond with identification mark on Shop Drawings. Mark each panel with its casting date.

2.10 FABRICATION TOLERANCES

- A. Manufacturing Tolerances: Manufacture GFRC panels so each finished unit complies with the following dimensional tolerances. For dimensional tolerances not listed below, comply with PCI MNL 130.
 - 1. Overall Height and Width of Units, Measured at the Face Adjacent to Mold: As follows:
 - a. 10 feet or less, plus or minus 1/8 inch.

- b. More than 10 feet, plus or minus 1/8 inch per 10 feet; 1/4 inch maximum.
2. Edge Return Thickness: Plus 1/2 inch, minus 0 inch.
 3. Architectural Facing Thickness: Plus 1/8 inch, minus 0 inch.
 4. Backing Thickness: Plus 1/4 inch, minus 0 inch.
 5. Panel Depth from Face of Skin to Back of Panel Frame or Integral Rib: Plus 3/8 inch, minus 1/4 inch.
 6. Angular Variation of Plane of Side Mold: Plus or minus 1/32 inch per 3 inches of depth or plus or minus 1/16 inch total, whichever is greater.
 7. Variation from Square or Designated Skew (Difference in Length of Two Diagonal Measurements): Plus or minus 1/8 inch per 72 inches or plus or minus 1/4 inch total, whichever is greater.
 8. Local Smoothness: 1/4 inch per 10 feet.
 9. Bowing: Not to exceed L/360 unless unit meets erection tolerances using connection adjustments.
 10. Length and Width of Block Outs and Openings within One Unit: Plus or minus 1/4 inch.
 11. Location of Window Opening within Panel: Plus or minus 1/4 inch.
 12. Maximum Permissible Warpage of One Corner out of the Plane of the Other Three: 1/16 inch per 12 inches of distance from nearest adjacent corner.
- B. Position Tolerances: Measured from datum line locations, as indicated on Shop Drawings.
1. Panel Frame and Track: Plus or minus 1/4 inch.
 2. Flashing Reglets at Edge of Panel: Plus or minus 1/4 inch.
 3. Inserts: Plus or minus 1/2 inch.
 4. Special Handling Devices: Plus or minus 3 inches.
 5. Location of Bearing Devices: Plus or minus 1/4 inch.
 6. Blockouts: Plus or minus 3/8 inch.
- C. Panel Frame Tolerances: As follows:
1. Vertical and Horizontal Alignment: 1/4 inch per 10 feet.
 2. Spacing of Framing Member: Plus or minus 3/8 inch.
 3. Squareness of Frame: Difference in length of diagonals of 3/8 inch.
 4. Overall Size of Frame: Plus or minus 3/8 inch.

2.11 APPEARANCE AND FINISHES

- A. Finish exposed-face surfaces of GFRC as follows to match approved design reference sample and mockups. Panel faces shall be free of joint marks, grain, or other obvious defects.
1. Smooth-Surface Finish: Provide free of sand streaks, honeycombs, and excessive air voids, with uniform color and texture.
 2. Simulate the following appearance for initial sample selection: White Color and fine grain texture to simulate painted wood.

2.12 SOURCE QUALITY CONTROL

- A. Quality-Control Testing: Establish and maintain a quality-control program for manufacturing GFRC panels according to PCI MNL 130.
 - 1. Test materials and inspect production techniques.
 - 2. Quality-control program shall monitor glass-fiber content, spray rate, unit weight, product physical properties, anchor pull-off and shear strength, and curing period and conditions.
 - 3. Prepare test specimens and test according to ASTM C 1228, PCI MNL 130, and PCI MNL 128 procedures.
 - 4. Test GFRC inserts and anchors according to ASTM C 1230 to validate design values.
 - 5. Produce test boards at a rate not less than one per work shift per operator for each spray machine and for each mix design.
 - a. For each test board, determine glass-fiber content according to ASTM C 1229, and flexural yield and ultimate strength according to ASTM C 947.

PART 3 - EXECUTION

3.1 EXAMINATION

- A. Examine structure and conditions for compliance with requirements for installation tolerances, true and level bearing surfaces, and other conditions affecting performance.
 - 1. Proceed with installation only after unsatisfactory conditions have been corrected.

3.2 ERECTION

- A. Install clips, hangers, and other accessories required for connecting GFRC panels to supporting members and backup materials.
- B. Lift GFRC panels and install without damage.
- C. Install GFRC panels level, plumb, square, and in alignment. Provide temporary supports and bracing as required to maintain position, stability, and alignment of panels until permanent connections are completed.
 - 1. Maintain horizontal and vertical joint alignment and uniform joint width.
 - 2. Remove projecting hoisting devices.
- D. Connect GFRC panels in position by bolting or welding, or both, as indicated on Shop Drawings. Remove temporary shims, wedges, and spacers as soon as possible after connecting is completed.
- E. Welding: Comply with applicable AWS D1.1 and AWS D1.3 requirements for welding, appearance, quality of welds, and methods used in correcting welding work.

1. Protect GFRC panels from damage by field welding or cutting operations, and provide noncombustible shields as required.
- F. At bolted connections, use lock washers or other acceptable means to prevent loosening of nuts.

3.3 ERECTION TOLERANCES

A. Erect GFRC panels to comply with the following noncumulative tolerances:

1. Plan Location from Building Grid Datum: Plus or minus 1/2 inch.
2. Top Elevation from Nominal Top Elevation: As follows:
 - a. Exposed Individual Panel: Plus or minus 1/4 inch.
 - b. Nonexposed Individual Panel: Plus or minus 1/2 inch.
 - c. Exposed Panel Relative to Adjacent Panel: 1/4 inch.
 - d. Nonexposed Panel Relative to Adjacent Panel: 1/2 inch.
3. Support Elevation from Nominal Elevation: As follows:
 - a. Maximum Low: 1/2 inch.
 - b. Maximum High: 1/4 inch.
4. Maximum Plumb Variation over the Lesser of Height of Structure or 100 Feet: 1 inch.
5. Plumb in Any 10 Feet of Element Height: 1/4 inch.
6. Maximum Jog in Alignment of Matching Edges: 1/4 inch.
7. Maximum Jog in Alignment of Matching Faces: 1/4 inch.
8. Face Width of Joint: As follows (governs over joint taper):
 - a. Panel Dimension 20 Feet or Less: Plus or minus 1/4 inch.
 - b. Panel Dimension More Than 20 Feet: Plus or minus 5/16 inch.
9. Maximum Joint Taper: 3/8 inch.
10. Joint Taper in 10 Feet: 1/4 inch.
11. Differential Bowing, as Erected, between Adjacent Members of Same Design: 1/4 inch.

3.4 REPAIRS

- A. Repairs will be permitted provided structural adequacy of GFRC panel and appearance are not impaired, as approved by Architect.
- B. Mix patching materials and repair GFRC so cured patches blend with color, texture, and uniformity of adjacent exposed surfaces.
- C. Prepare and repair accessible damaged galvanized coatings with galvanizing repair paint according to ASTM A 780.
- D. Wire brush, clean, and paint accessible weld areas on prime-painted components with same type of shop primer.

- E. Remove and replace damaged GFRC panels when repairs do not comply with requirements.

3.5 CLEANING AND PROTECTION

- A. Perform cleaning procedures, if necessary, according to GFRC manufacturer's written instructions. Clean soiled GFRC surfaces with detergent and water, using soft fiber brushes and sponges, and rinse with clean water. Prevent damage to GFRC surfaces and staining of adjacent materials.

END OF SECTION 03 49 10

SECTION 042210 - UNIT MASONRY ASSEMBLIES

PART 1 - GENERAL

1.1 RELATED DOCUMENTS

- A. Drawings and general provisions of the Contract, including General and Supplementary Conditions and Division 1 Specification Sections, apply to this Section.

1.2 SUMMARY

- A. This Section includes unit masonry assemblies consisting of the following:
 - 1. Concrete masonry units (CMUs).
 - 2. Face Brick
 - 3. Mortar and grout.
 - 4. Mortar color.
 - 5. Masonry joint reinforcement.
 - 6. Ties and anchors.
 - 7. Reinforced masonry.
 - 8. Embedded flashing
 - 9. Miscellaneous masonry accessories.
- B. Related Sections include the following:
 - 1. Division 7 Section "Joint Sealants" for sealing control and expansion joints in unit masonry.
- C. Products installed, but not furnished, under this Section include the following:
 - 1. Steel lintels and shelf angles for unit masonry.

1.3 DEFINITIONS

- A. Reinforced Masonry: Masonry containing reinforcing steel in grouted cells.

1.4 PERFORMANCE REQUIREMENTS

- A. Provide structural unit masonry that develops indicated net-area compressive strengths (f_m) at 28 days.
- B. Determine net-area compressive strength (f_m) of masonry from average net-area compressive strengths of masonry units and mortar types (unit-strength method) according to Tables 1 and 2 in ACI 530.1/ASCE 6/TMS 602 and as indicated:

1. Provide structural unit masonry that develops net-area compressive strengths of no less than 2,000psi f'm at 28 days.
 2. Design of ties and anchorage shall comply with seismic design category indicated.
- C. Field Testing: Where testing agency determines in place construction requires verification, determine net-area compressive strength (f'm) of masonry by testing masonry prisms according to ASTM C 1314, and in accordance with Part 3 of these specifications.

1.5 SUBMITTALS

- A. Product Data: For each type of product indicated.
- B. Shop Drawings: For the following:
1. Masonry Units: Show sizes, profiles, coursing, and locations of special shapes.
 2. Reinforcing Steel: Detail bending and placement of unit masonry reinforcing bars. Comply with ACI 315, "Details and Detailing of Concrete Reinforcement." Show elevations of reinforced walls.
 3. Fabricated Flashing: Detail corner units, end-dam units, and other special applications.
 4. Draw elevations and show recommendations for vertical control and expansion joints in masonry where not already indicated.
- C. Samples for Verification: For each type and color of the following:
1. Special brick and CMU shapes.
 2. Accessories embedded in masonry.
- D. Qualification Data: For testing agency.
- E. Material Certificates: Include statements of material properties indicating compliance with requirements including compliance with standards and type designations within standards. Provide for each type and size of the following:
1. Masonry units.
 - a. Include material test reports substantiating compliance with requirements.
 - b. For bricks, include size-variation data verifying that actual range of sizes falls within specified tolerances.
 - c. For exposed brick, include material test report for efflorescence according to ASTM C 67.
 - d. For masonry units used in structural masonry, include data and calculations establishing average net-area compressive strength of units.
 2. Cementitious materials. Include brand, type, and name of manufacturer.
 3. Pre-blended, dry mortar mixes. Include description of type and proportions of ingredients.
 4. Grout mixes. Include description of type and proportions of ingredients.
 5. Reinforcing bars.

6. Joint reinforcement.
 7. Anchors, ties, and metal accessories.
- F. Mix Designs: For each type of mortar and grout. Include description of type and proportions of ingredients.
1. Include test reports, per ASTM C 780, for mortar mixes required to comply with property specification.
 2. Include test reports, per ASTM C 1019, for grout mixes required to comply with compressive strength requirement.
- G. Statement of Compressive Strength of Masonry: For each combination of masonry unit type and mortar type, provide statement of average net-area compressive strength of masonry units, mortar type, and resulting net-area compressive strength of masonry determined according to Tables 1 and 2 in ACI 530.1/ASCE 6/TMS 602.
- H. Engineering calculations or written verification from the tie manufacturer for the wall ties type and spacing for veneer construction with air space cavities 4 inches in depth or greater, regardless of wall height. Provide separate verification statements for each wall condition.
- I. Cold-Weather Procedures: Detailed description of methods, materials, and equipment to be used to comply with cold-weather requirements.

1.6 QUALITY ASSURANCE

- A. Testing Agency Qualifications: An independent agency qualified according to ASTM C 1093 for testing indicated, as documented according to ASTM E 548.
- B. Source Limitations for Mortar Materials: Obtain mortar ingredients of an International quality, including color for exposed masonry, from a single manufacturer for each cementitious component and from one source or producer for each aggregate.
- C. Fire-Resistance Ratings: Where indicated, provide materials and construction identical to those of assemblies with fire-resistance ratings determined per ASTM E 119 by a testing and inspecting agency, by equivalent concrete masonry thickness, or by other means, as acceptable to authorities having jurisdiction.
- D. Mockups: Build mockups to verify selections made under sample submittals and to demonstrate aesthetic effects and set quality standards for materials and execution.
1. Build mockups for typical exterior walls in sizes approximately 72 inches long by 72 inches high by full thickness, including face, backup assemblies and accessories.
 2. Build one mockup each for representative masonry wall and metal stud wall backup assemblies.
 - a. Include a sealant-filled joint at least 16 inches long in each mockup.
 - b. Stagger construction layers to expose the typically concealed components of the wall construction.
 3. Clean exposed faces of mockups with masonry cleaner as indicated.

4. Protect accepted mockups from the elements with weather-resistant membrane.
 5. Approval of mockups is for color, texture, and blending of masonry units; relationship of mortar and sealant colors to masonry unit colors; tooling of joints; and aesthetic qualities of workmanship.
 - a. Approval of mockups does not constitute approval of deviations from the Contract Documents contained in mockups, unless such deviations are specifically approved by Architect in writing.
 6. Approved mockups may become part of the completed Work if undisturbed at time of Final Acceptance.
- E. Preinstallation Conference: Conduct conference at Project site to comply with requirements in Division 1 Section "Project Management and Coordination."

1.7 DELIVERY, STORAGE, AND HANDLING

- A. Store masonry units on elevated platforms in a dry location. If units are not stored in an enclosed location, cover tops and sides of stacks with waterproof sheeting, securely tied. If units become wet, do not install until they are dry.
 1. Limit moisture absorption of concrete masonry units until time of installation to maximum percentage specified for Type 1 units for average annual relative humidity as determined by the National Weather Service.
- B. Store cementitious materials on elevated platforms, under cover, and in a dry location. Do not use cementitious materials that have become damp.
- C. Store aggregates where grading and other required characteristics can be maintained, and contamination avoided.
- D. Deliver pre-blended, dry mortar mix in moisture-resistant containers designed for lifting and emptying into dispensing silo. Store pre-blended, dry mortar mix in delivery containers on elevated platforms, under cover, and in a dry location or in a metal dispensing silo with weatherproof cover.
- E. Store masonry accessories, including metal items, to prevent corrosion and accumulation of dirt and oil.

1.8 PROJECT CONDITIONS

- A. Protection of Masonry: During construction, cover tops of walls, projections, and sills with waterproof sheeting at end of each day's work. Cover partially completed masonry when construction is not in progress.
 1. Extend cover a minimum of 24 inches down both sides and hold cover securely in place.
 2. Where 1 wythe of multiwythe masonry walls is completed in advance of other wythes, secure cover a minimum of 24 inches down face next to unconstructed wythe and hold cover in place.

- B. Do not apply floor or roof loads for at least 12 hours and concentrated loads for at least 3 days after building masonry walls or columns.
- C. Stain Prevention: Prevent grout, mortar, and soil from staining the face of masonry to be left exposed or painted. Immediately remove grout, mortar, and soil that come in contact with such masonry.
 - 1. Protect sills, ledges, and projections from mortar droppings.
 - 2. Protect surfaces of window and doorframes, as well as similar products with painted and integral finishes, from mortar droppings.
- D. Cold-Weather Requirements: Do not use frozen materials or materials mixed or coated with ice or frost. Do not build on frozen substrates. Remove and replace unit masonry damaged by frost or by freezing conditions. Comply with cold-weather construction requirements contained in Section 2104.3 in the International Building Code and as follows.
 - 1. Subject to union restrictions for working at low temperatures, perform the following construction procedures while masonry work is progressing. Temperature ranges indicated below apply to air temperatures existing at time of installation except for grout. For grout, temperature ranges apply to anticipated minimum night temperatures. In heating mortar and grout materials, maintain mixing temperature selected within 10degF.
 - 2. 40 deg F to 32 deg F:
 - a. Mortar: Heat mixing water to produce mortar temperature between 40degF and 120degF.
 - b. Grout: Follow normal masonry procedures.
 - 3. 32 deg F to 25 deg F:
 - a. Mortar: Heat mixing water and sand to produce mortar temperatures between 40degF and 120degF; maintain temperature on mortar board to above freezing.
 - b. Grout: Heat grout materials to 90degF to produce in-place grout temperatures of 70degF at end of workday.
 - 4. 25 deg F to 20 deg F:
 - a. Mortar: Heat mixing water and sand to produce mortar temperatures between 40degF and 120degF; maintain temperature on mortar board to above freezing.
 - b. Grout: Heat grout materials to 90degF to produce in-place grout temperatures of 70degF at end of workday.
 - c. Heat both sides of walls under construction using salamanders or other heat sources.
 - d. Use windbreaks or enclosures when wind is in excess of 15mph.
 - 5. 20 deg F and below:
 - a. Mortar: Heat mixing water to produce mortar temperature between 40degF and 120degF.
 - b. Grout: Heat grout materials to 90degF to produce in-place grout temperatures of 70degF at end of workday.
 - c. Masonry units: heat masonry units so that they are above 20 deg. F at time of laying.

- d. Provide enclosures and auxiliary heat to maintain and air temperature of at least 40 deg F for 24 hours after laying units.
 6. Do not heat water for mortar or grout to above 160 deg F.
 7. Cold-Weather Cleaning: Use liquid cleaning methods only when air temperature is 40 deg F and above and will remain so until masonry has dried, but not less than 7 days after completing cleaning.
 - E. Protect completed masonry and masonry not being worked on in the following manner. Temperature ranges indicated below apply to mean daily air temperatures except for grout. For grouted masonry, temperature ranges apply to anticipated nightly temperatures.
 1. 40 deg F to 32 deg F:
 - a. Protect masonry from rain or snow for at least 24 hours by covering with weather resistive membrane.
 2. 32 deg F to 25 deg F:
 - a. Completely cover masonry with weather resistive membrane for at least 24 hours.
 3. 25 deg F to 20 deg F:
 - a. Completely cover masonry with weather-resistive insulating blankets or similar protection for at least 24 hours, 48 hours for grouted masonry.
 4. 20 deg F and below:
 - a. Except as otherwise indicated, maintain masonry temperatures above 32 deg F for 23 hours using enclosures and supplementary heat, electric heating blankets, infrared lamps or other methods proven to be satisfactory. For grouted masonry, maintain heated enclosure to 40 deg F for 48 hours.
 - F. Hot-Weather Requirements: Comply with hot-weather construction requirements contained in ACI 530.1/ASCE 6/TMS 602.

PART 2 - PRODUCTS

2.1 MASONRY UNITS, GENERAL

- A. Defective Units: Referenced masonry unit standards may allow a certain percentage of units to exceed tolerances and to contain chips, cracks, or other defects exceeding limits stated in the standard. Do not use units where such defects, including dimensions that vary from specified dimensions by more than stated tolerances, will be exposed in the completed Work or will impair the quality of completed masonry.

2.2 CONCRETE MASONRY UNITS (CMUs)

- A. Shapes: Provide shapes indicated and as follows:

1. Provide special shapes for lintels, corners, jambs, sashes, movement joints, headers, bonding, and other special conditions.
2. Provide bullnose units for outside corners, unless otherwise indicated.
 - a. Saw cut back-to-back units are acceptable where double bullnose at end of wall is required.
3. Provide all square cut outside corner units for first course in rooms to receive tile baseboard finish.

B. Concrete Masonry Units: ASTM C 90-14.

1. Unit Compressive Strength: As indicated for minimum average net-area compressive strength.
2. Weight Classification: Lightweight unless otherwise indicated.
3. Size: Manufacturer's standard units with nominal face dimensions of 16" long x 8" high by thickness indicated:
 - a. Manufactured to dimensions 3/8 inch less than nominal dimensions.
4. Shape: Provide blocks with single score (vertical) to match existing CMU in project.
5. Type 1, moisture-controlled units.

2.3 BRICK

A. General: Provide shapes indicated and as follows:

1. For ends of sills and caps and for similar applications that would otherwise expose unfinished brick surfaces, provide units without cores or frogs and with exposed surfaces finished.
2. Provide special shapes for applications where stretcher units cannot accommodate special conditions, including those at corners, movement joints, bond beams, sashes, and lintels.
3. Provide special shapes for applications requiring brick of size, form, color, and texture on exposed surfaces that cannot be produced by sawing.

B. Face Brick: ASTM C 216, Grade SW, Type FBS.

1. Unit Compressive Strength: Provide units with minimum average net-area compressive strength indicated.
2. Initial Rate of Absorption: Less than 30 g/30 sq. in. per minute when tested per ASTM C 67.
3. Efflorescence: Provide brick that has been tested according to ASTM C 67 and is rated "not effloresced."
4. Size (Actual Dimensions): To match existing building.
5. Application: Use where brick is exposed, unless otherwise indicated.

6. Color, Texture and Blend: To match existing building. **All face brick must be through the body color brick. Break a sample for the Owner's representative to review with sample panel.**
7. Acceptable Manufacturers:
 - a. Triangle Brick.
 - b. Palmetto Brick Company.
 - c. Adams Products.
 - d. Cherokee Sanford Brick.
 - e. Forterra (Hanson)
8. Basis of Design: Forterra (Hanson) Brentwood 1481 Modular Roseboro

2.4 MORTAR AND GROUT MATERIALS

- A. Portland Cement: ASTM C 150, Type I, except Type III may be used for cold-weather construction. Provide natural color or white cement as required to produce mortar color indicated.
- B. Hydrated Lime: ASTM C 207, Type S.
- C. Portland Cement-Lime Mix: Packaged blend of portland cement complying with ASTM C 150, Type I, and hydrated lime complying with ASTM C 207, Type S.
- D. Masonry Cement: not allowed.
- E. Mortar Cement: ASTM C 1329
- F. Mortar Pigments: Contractor shall provide pigmented mortar if required to match existing. Natural and synthetic iron oxides and chromium oxides, compounded for use in mortar mixes. Use only pigments with a record of satisfactory performance in masonry mortar.
 1. Available Products:
 - a. Bayer Corporation, Industrial Chemicals Div.; Bayferrox Iron Oxide Pigments.
 - b. Davis Colors; True Tone Mortar Colors.
 - c. Solomon Grind-Chem Services, Inc.; SGS Mortar Colors.
 - d. Approved equals.
- G. Aggregate for Mortar: ASTM C 144.
 1. For joints less than 1/4-inch thick, use aggregate graded with 100 percent passing the No. 16 sieve.
 2. Colored-Mortar Aggregates: Natural sand or crushed stone of color necessary to produce required mortar color.
- H. Aggregate for Grout: ASTM C 404.
- I. Water: Potable.

2.5 REINFORCEMENT

- A. Uncoated Steel Reinforcing Bars: ASTM A 615/A 615M or ASTM A 996/A 996M, Grade 60.
- B. Masonry Joint Reinforcement, General: Ladder type ASTM A 951.
 - 1. Interior Walls: Hot-dip galvanized, carbon steel.
 - 2. Interior Walls exposed to Natatorium environments: Stainless steel.
 - 3. Exterior Walls: Hot-dip galvanized, carbon steel.
 - 4. Wire Size for Side Rods: 0.148-inch diameter.
 - 5. Wire Size for Cross Rods: 0.148-inch diameter.
 - 6. Wire Size for Veneer Ties: 0.148-inch diameter.
 - 7. Spacing of Cross Rods, Tabs, and Cross Ties: Not more than 16 inches o.c.
 - 8. Provide in lengths of not less than 10 feet, with prefabricated corner and tee units.
- C. Masonry Joint Reinforcement for Single-Wythe Masonry: Ladder type with single pair of side rods.
- D. Masonry Joint Reinforcement for Multiwythe Masonry:
 - 1. Ladder type with 1 side rod at each face shell of hollow masonry units more than 4 inches wide, plus 1 side rod at each wythe of masonry 4 inches wide or less.
 - 2. Tab type, ladder design, with 1 side rod at each face shell of backing wythe and with rectangular tabs sized to extend at least halfway through facing wythe but with at least 5/8-inch cover on outside face.
 - 3. Adjustable (two-piece) type, ladder design, with one side rod at each face shell of backing wythe and with separate adjustable ties with pintle-and-eye connections having a maximum adjustment of 1-1/4 inches. Size ties to extend at least halfway through facing wythe but with at least 5/8-inch cover on outside face.
- E. Masonry Joint Reinforcement for Veneers Anchored with Seismic Masonry-Veneer Anchors: Single 0.187-inch- diameter, hot-dip galvanized, carbon-steel continuous wire.

2.6 TIES AND ANCHORS

- A. Materials: Provide ties and anchors specified in subsequent paragraphs that are made from materials that comply with subparagraphs below, unless otherwise indicated.
 - 1. Hot-Dip Galvanized, Carbon-Steel Wire: ASTM A 82; with ASTM A 153/A 153M, Class B-2 coating.
 - 2. Stainless-Steel Wire: ASTM A 580/A 580M, Type 304.
 - 3. Galvanized Steel Sheet: ASTM A 653/A 653M, Commercial Steel, G60 zinc coating.
 - 4. Stainless-Steel Sheet: ASTM A 666, Type 304.
 - 5. Steel Plates, Shapes, and Bars: ASTM A 36/A 36M.
 - 6. Stainless-Steel Bars: ASTM A 276 or ASTM a 666, Type 304.

- B. Corrugated Metal Ties (limited use): Metal strips not less than 7/8 inch wide with corrugations made of steel sheet, galvanized after fabrication not less than 0.067 inch thick.
1. Expansion Joints: Provide corrugated metal strips locally along interior steel frames and masonry substrates anchoring masonry either side of through wall expansion joints (capable of compression) in CMU and clay masonry wall assemblies, regardless of other anchoring types required in the same plane.
- C. Wire Ties, General: Unless otherwise indicated, size wire ties to extend at least halfway through veneer but with at least 5/8-inch cover on outside face. Outer ends of wires are bent 90 degrees and extend 2 inches parallel to face of veneer.
- D. Individual Wire Ties: Rectangular units with closed ends and not less than 4 inches wide.
1. Where wythes do not align, use adjustable ties with pintle-and-eye connections having a maximum adjustment of 1-1/4 inches.
 2. Wire: Fabricate from 0.148 diameter hot-dip galvanized steel or stainless-steel wire. Mill-galvanized wire ties may be used in interior walls, unless otherwise indicated.
- E. Adjustable Anchors for Connecting to Structure: Provide anchors that allow vertical or horizontal adjustment but resist tension and compression forces perpendicular to plane of wall.
1. Anchor Section for Welding to Steel Frame: Crimped 1/4-inch- diameter, hot-dip galvanized steel or stainless-steel wire.
 2. Tie Section for Steel Frame: Triangular-shaped wire tie, sized to extend within 1 inch of masonry face, made from 0.25-inch- diameter, hot-dip galvanized steel or stainless-steel wire.
 3. Corrugated ties screw fastened to steel framing when veneer is isolated with expansion joints.
- F. Adjustable Masonry-Veneer Anchors: **(Brick Veneer Anchors)**
1. General: Provide anchors that allow vertical adjustment but resist tension and compression forces perpendicular to plane of wall, for attachment over sheathing metal studs, and as follows:
 - a. Structural Performance Characteristics: Capable of withstanding a 100-lbf load in both tension and compression without deforming or developing play in excess of 0.05 inch.
 2. Screw-Attached, Masonry-Veneer Anchors: Units consisting of a wire tie and a barrel style anchor section.
 - a. Anchor Section: Barrel style brick tie anchors brick through continuous insulation to concrete masonry unit substrate.
 - b. Wire Ties: Triangular-, rectangular-, or T-shaped wire ties fabricated from 0.25-inch- diameter, hot-dip galvanized steel or stainless-steel wire. Provide wire tie as recommended by anchor manufacturer.
 - c. Basis of Design: Hohmann & Barnard, Inc: Thermal 2-Seal Concrete seal tie. Subject to compliance with requirements, comparable products may be provided by one of the following:

- 1) Wire-Bond.
- 2) Heckmann Building Products, Inc.

2.7 MISCELLANEOUS ANCHORS

- A. Anchor Bolts: Headed steel bolts complying with ASTM A 307, Grade A; with ASTM A 563 hex nuts and, where indicated, flat washers; hot-dip galvanized to comply with ASTM A 153/A 153M, Class C; of dimensions indicated.

2.8 EMBEDDED FLASHING MATERIALS

- A. Metal Flashing: Provide metal flashing, where flashing is exposed or partly exposed and where indicated, complying with SMACNA's "Architectural Sheet Metal Manual".
- B. Flexible Flashing: For flashing not exposed to the exterior, use the following, unless otherwise indicated:
 1. Copper-Laminated Flashing: 5-oz./sq. ft. copper sheet bonded with asphalt between 2 layers of glass-fiber cloth. Use only where flashing is fully concealed in masonry.
 - a. Products:
 - 1) Advanced Building Products Inc.; Copper Fabric Flashing.
 - 2) AFCO Products Inc.; Copper Fabric.
 - 3) Hohmann & Barnard, Inc.; H & B C-Fab Flashing.
 - 4) Phoenix Building Products; Type FCC-Fabric Covered Copper.
 - 5) Polytite Manufacturing Corp.; Copper Fabric Flashing.
 - 6) Sandell Manufacturing Co., Inc.; Copper Fabric Flashing.
 - 7) York Manufacturing, Inc.; York Copper Fabric Flashing.
 2. Fabricate through wall flashing with 304 or 316 stainless steel drip edge. Project drip edge out from wall face ½ inch and bent to a 30-degree angle and fully hemmed.
 3. Accessories: Provide preformed corners, end dams, other special shapes, and seaming materials produced by flashing manufacturer. Field formed corners are not acceptable unless methods and materials are approved by the manufacturer.
- C. Solder and Sealants for Sheet Metal Flashings:
 1. Solder for Copper: ASTM B 32, Grade Sn50, 50 percent tin and 50 percent lead.
 2. Elastomeric Sealant: ASTM C 920, chemically curing urethane sealant; of type, grade, class, and use classifications required to seal joints in sheet metal flashing and trim and remain watertight.

2.9 MISCELLANEOUS MASONRY ACCESSORIES

- A. Compressible Filler (Top of wall cavity and top of exterior wall closures): Premolded filler strips complying with ASTM D 1056, Grade 2A1; compressible up to 35 percent; of width and thickness indicated; formulated from neoprene.

- B. Preformed Control-Joint Gaskets: Made from styrene-butadiene-rubber compound, complying with ASTM D 2000, Designation M2AA-805 or PVC, complying with ASTM D 2287, Type PVC-65406 and designed to fit standard sash block and to maintain lateral stability in masonry wall; size and configuration as indicated.
- C. Bond-Breaker Strips: Asphalt-saturated, organic roofing felt complying with ASTM D 226, Type I (No. 15 asphalt felt).
- D. Weep/Vent Products: Use the following, unless otherwise indicated:
 - 1. Mesh Weep/Vent: Free-draining mesh; made from polyethylene strands, full height and width of head joint and depth 1/8 inch less than depth of outer wythe; in color selected from manufacturer's standard.
- E. Cavity Drainage Material: Free-draining mesh, made from polymer strands that will not degrade within the wall cavity.
 - 1. Strips, full-depth of cavity and 10 inches wide, with dovetail shaped notches 7 inches deep that prevent mesh from being clogged with mortar droppings.
 - 2. Available Products:
 - a. Advanced Building Products Inc.; Mortar Break.
 - b. Archovations, Inc.; CavClear Masonry Mat.
 - c. Dayton Superior Corporation, Dur-O-Wal Division; Polytite MortarStop.
 - d. Mortar Net USA, Ltd.; Mortar Net.

2.10 MASONRY CLEANERS

- A. Proprietary Acidic Cleaner: Manufacturer's standard-strength cleaner designed for removing mortar/grout stains, efflorescence, and other new construction stains from new masonry without discoloring or damaging masonry surfaces. Use product expressly approved for intended use by cleaner manufacturer and manufacturer of masonry units being cleaned.
 - 1. Basis of Design: Provide ProSoCo, Inc. Sure Kleen No. 600 Detergent, except for brick subject to metallic oxidation, use Sure Kleen VanaTrol. Subject to compliance with requirements, provide comparable products by one of the following:
 - a. Diedrich Technologies, Inc.
 - b. Bonstone, Inc.

2.11 MORTAR AND GROUT MIXES

- A. General: Do not use admixtures, including pigments, air-entraining agents, accelerators, retarders, water-repellent agents, antifreeze compounds, or other admixtures, unless otherwise indicated.
 - 1. Do not use calcium chloride in mortar or grout.
 - 2. Limit cementitious materials in mortar to portland cement and lime.
 - 3. Limit cementitious materials in mortar for exterior and reinforced masonry to portland cement and lime.

- B. Mortar for Concrete Unit Masonry: Comply with ASTM C 270, Proportion Specification. Provide the following types of mortar for applications stated unless another type is indicated.
 - 1. For masonry below grade or in contact with earth, use Type S.
 - 2. For reinforced masonry, use Type S.
 - 3. For exterior, above-grade, load-bearing and non-load-bearing walls and parapet walls; for interior load-bearing walls; for interior non-load-bearing partitions; and for other applications where another type is not indicated, use Type S.
 - 4. For interior non-load-bearing partitions, Type N.
- C. Mortar for Brick Masonry: Comply with ASTM C 270, Proportion Specification. Provide the following types of mortar for applications stated unless another type is indicated.
 - 1. For masonry below grade in contact with earth, use Type S.
 - 2. For masonry above grade use Type N.
- D. Pigmented Mortar: Use colored cement product or select and proportion pigments with other ingredients to produce color required. Do not add pigments to colored cement products.
 - 1. Pigments shall not exceed 10 percent of portland cement by weight.
 - 2. Mix to match Architect's sample.
- E. Grout for Unit Masonry: Comply with ASTM C 476.
 - 1. Use grout of type indicated or, if not otherwise indicated, of type (fine or coarse) that will comply with Table 1.15.1 in ACI 530.1/ASCE 6/TMS 602 for dimensions of grout spaces and pour height.
 - 2. Provide grout with a slump of 8 to 11 inches as measured according to ASTM C 143/C 143M.

2.12 SOURCE QUALITY CONTROL

- A. At Owner option: Owner will engage a qualified independent testing agency to perform source quality-control testing:
 - 1. Clay Masonry Unit Test: For each type of unit furnished, per ASTM C 67.
 - 2. Concrete Masonry Unit Test: For each type of unit furnished, per ASTM C 140.
- B. Payment for these services will be made by Owner.
 - 1. Retesting of materials failing to comply with specified requirements shall be done at Contractor's expense.

PART 3 - EXECUTION

3.1 EXAMINATION

- A. Proceed with installation only after unsatisfactory conditions have been corrected.

3.2 INSTALLATION, GENERAL

- A. Thickness: Build cavity and composite walls and other masonry construction to full thickness shown. Build single-wythe walls to actual widths of masonry units, using units of widths indicated.
- B. Build chases and recesses to accommodate items specified in this and other Sections.
 - 1. Provide no less than 8" of masonry between chase or recess and jamb of openings, and between adjacent chases and recesses.
- C. Leave openings for equipment to be installed before completing masonry. After installing equipment, complete masonry to match the construction immediately adjacent to opening.
- D. Use full-size units without cutting if possible. If cutting is required to provide a continuous pattern or to fit adjoining construction, cut units with motor-driven saws; provide clean, sharp, unchipped edges. Allow units to dry before laying unless wetting of units is specified. Install cut units with cut surfaces and, where possible, cut edges concealed.
- E. Select and arrange units for exposed unit masonry to produce an International blend of colors and textures.
 - 1. Mix units from several pallets or cubes as they are placed.
- F. Wetting of Brick: Wet brick before laying if initial rate of absorption exceeds 30 g/30 sq. in. per minute when tested per ASTM C 67. Allow units to absorb water so they are damp but not wet at time of laying.
- G. Do not wet concrete masonry units.
- H. Comply with construction tolerances in ACI 530.1/ASCE 6/TMS 602 and with the following:
 - 1. For conspicuous vertical lines, such as external corners, door jambs, reveals, and expansion and control joints, do not vary from plumb by more than 1/8 inch in 10 feet, 1/4 inch in 20 feet, or 1/2 inch maximum.
 - 2. For vertical alignment of exposed head joints, do not vary from plumb by more than 1/4 inch in 10 feet, or 1/2 inch maximum.
 - 3. For conspicuous horizontal lines, such as lintels, sills, parapets, and reveals, do not vary from level by more than 1/8 inch in 10 feet, 1/4 inch in 20 feet, or 1/2 inch in 40 feet or more.
 - 4. For exposed bed joints, do not vary from thickness indicated by more than plus or minus 1/8 inch, with a maximum thickness limited to 1/2 inch. Do not vary from bed-joint thickness of adjacent courses by more than 1/8 inch.
 - 5. For exposed head joints, do not vary from thickness indicated by more than plus or minus 1/8 inch. Do not vary from adjacent bed-joint and head-joint thicknesses by more than 1/8 inch.
 - 6. For faces of adjacent exposed masonry units, do not vary from flush alignment by more than 1/16 inch except due to warpage of masonry units within tolerances specified for warpage of units.

7. For exposed bed joints and head joints of stacked bond, do not vary from a straight line by more than 1/16 inch from one masonry unit to the next.

3.3 LAYING MASONRY WALLS

- A. Lay out walls in advance for accurate spacing of surface bond patterns with International joint thicknesses and for accurate location of openings, movement-type joints, returns, and offsets. Avoid using less-than-half-size units, particularly at corners, jambs, and, where possible, at other locations.
- B. Bond Pattern for Exposed CMU Masonry: Unless otherwise indicated, lay exposed masonry in running bond; do not use units with less than nominal 4-inch horizontal face dimensions at corners or jambs.
- C. Lay concealed masonry with all units in a wythe in running bond or bonded by lapping not less than 2 inches. Bond and interlock each course of each wythe at corners. Do not use units with less than nominal 4-inch horizontal face dimensions at corners or jambs.
- D. Stopping and Resuming Work: Stop work by racking back units in each course from those in course below; do not tooth. When resuming work, clean masonry surfaces that are to receive mortar, remove loose masonry units and mortar, and wet brick if required before laying fresh masonry.
- E. Built-in Work: As construction progresses, build in items specified in this and other Sections. Fill in solidly with masonry around built-in items.
- F. Fill space between steel frames and masonry solidly with mortar, unless otherwise indicated.
- G. Where built-in items are to be embedded in cores of hollow masonry units, place a layer of metal lath, wire mesh, or plastic mesh in the joint below and rod mortar or grout into core.
- H. Fill cores in hollow concrete masonry units with grout 24 inches under bearing plates, beams, lintels, posts, and similar items, unless otherwise indicated.
- I. Build non-load-bearing interior partitions full height of story to underside of solid floor or roof structure above, unless otherwise indicated.
 1. Install compressible filler in joint between top of partition and underside of structure above for non-rated partitions.
 2. Fasten partition top to structure above as indicated.
 3. At fire-rated partitions, treat joint between top of partition and underside of structure above to comply with Division 7 Section "Fire-Resistive Joint Systems."

3.4 MORTAR BEDDING AND JOINTING

- A. Lay hollow concrete masonry units as follows:
 1. With face shells fully bedded in mortar and with head joints of depth equal to bed joints.
 2. With webs fully bedded in mortar in all courses of piers, columns, and pilasters.

3. With webs fully bedded in mortar in grouted masonry, including starting course on footings.
 4. With entire units, including areas under cells, fully bedded in mortar at starting course on footings where cells are not grouted.
- B. Lay solid masonry units with completely filled bed and head joints; butter ends with sufficient mortar to fill head joints and shove into place. Do not deeply furrow bed joints or slush head joints.
 - C. Tool exposed joints slightly concave using jointer larger than joint thickness.
 - D. If adjustments are required after laying, remove unit clean off and reset with fresh mortar. Do not pound corners or jambs to shift adjacent stretcher units which are set.

3.5 CAVITY WALLS

- A. Bond wythes of cavity walls together using one of the following methods:
 1. Individual Metal Ties: Provide ties installed in horizontal joints, but not less than one metal tie for 1.87 sq. ft. of wall area spaced not to exceed 16 inches o.c. horizontally and 16 inches o.c. vertically. Stagger ties in alternate courses. Provide additional ties within 12 inches of openings and space not more than 18 inches apart around perimeter of openings. At intersecting and abutting walls, provide ties at no more than 16 inches o.c. vertically.
 2. Masonry Joint Reinforcement: Installed in horizontal mortar joints.
 - a. Where bed joints of both wythes align, use tab-type reinforcement.
 - b. Where bed joints of wythes do not align, use adjustable (two-piece) type reinforcement with continuous horizontal wire in facing wythe attached to ties.
 3. Masonry Veneer Anchors: Comply with requirements for anchoring masonry veneers.
- B. Keep cavities clean of mortar droppings and other materials during construction. Bevel beds away from cavity, to minimize mortar protrusions into cavity. Do not attempt to trowel or remove mortar fins protruding into cavity.
- C. Coat cavity face of backup wythe to comply with Division 7 Section "Membrane Air and Vapor Barriers".

3.6 MASONRY JOINT REINFORCEMENT

- A. General: Install entire length of longitudinal side rods in mortar with a minimum cover of 5/8 inch on exterior side of walls, 1/2 inch elsewhere. Lap reinforcement a minimum of 6 inches.
 1. Space reinforcement not more than 16 inches o.c.
 2. Space reinforcement not more than 8 inches o.c. in foundation walls and parapet walls.
 3. Provide reinforcement not more than 8 inches above and below wall openings and extending 12 inches beyond openings.

- a. Reinforcement above is in addition to continuous reinforcement.
- B. Interrupt joint reinforcement at control and expansion joints, unless otherwise indicated.
- C. Provide continuity at wall intersections by using prefabricated T-shaped units.
- D. Provide continuity at corners by using prefabricated L-shaped units.
- E. Cut and bend reinforcing units as directed by manufacturer for continuity at corners, returns, offsets, column fireproofing, pipe enclosures, and other special conditions.

3.7 ANCHORING MASONRY TO STRUCTURAL MEMBERS

- A. Anchor masonry to structural members where masonry abuts or faces structural members to comply with the following:
 - 1. Provide an open space not less 1 inch in width between masonry and structural member, unless otherwise indicated. Keep open space free of mortar and other rigid materials.
 - 2. Anchor masonry to structural members with anchors embedded in masonry joints and attached to structure.
 - a. Where interior steel members occur within masonry wythes and adjacent to vertical expansion joints, use the specified corrugated ties attached to vertical steel members in lieu of rigid adjustable anchors.
 - b. Space anchors as indicated, but not more than 18 inches o.c. vertically and horizontally.

3.8 CONTROL AND EXPANSION JOINTS

- A. General: Install control and expansion joint materials in unit masonry where indicated. Where not indicated, locate vertical and horizontal expansion joints in accordance with Brick Institute of America (BIA) Technical Notes 18A. Provide recommendations in Coordinate locations with the Architect.
- B. Install control and expansion joints as masonry progresses. Do not allow materials to span control and expansion joints without provision to allow for in-plane wall or partition movement
 - 1. Install expansion joints in unit masonry at the ends of designated shear walls and where indicated on the drawings. Where not indicated, install control joints in masonry walls at regular intervals to accommodate building movement. Build-in related items as masonry progresses. Do not form a continuous span through movement joints unless provisions are made to prevent in-plane restraint of wall or partition movement.
 - 2. Form control joints in concrete masonry walls which are not designated shear walls as follows:
 - a. Fit bond-breaker strips into hollow contour in ends of concrete masonry units on one side of control joint. Fill resultant core with grout and rake joints in exposed faces. Reinforcing to be continuous through control joint.
 - b. Or use preformed non-metallic control joint gasket.

3. Form expansion joints in brick made from clay or shale as follows:
 - a. Build expansion joints to be continuous through the entire depth of wythe.
 - b. Build in compressible joint fillers where indicated.
- C. Provide horizontal, pressure-relieving joints by either leaving an air space or inserting a compressible filler of width required for installing sealant and backer rod specified in Division 7 Section "Joint Sealants," but not less than 3/8 inch.
 1. Locate horizontal, pressure-relieving joints beneath shelf angles supporting masonry.

3.9 LINTELS

- A. Install steel lintels only where indicated.
- B. Provide pre-cast or formed in place masonry lintels where shown and where openings of more than 12 inches for brick-size units and 24 inches for block-size units are shown without structural steel or other supporting lintels.
 1. Temporarily support formed in place lintels.
- C. Provide minimum bearing of 8 inches at each jamb, unless otherwise indicated.

3.10 REINFORCED UNIT MASONRY INSTALLATION

- A. Temporary Formwork and Shores: Construct formwork and shores as needed to support reinforced masonry elements during construction.
- B. Placing Reinforcement: Comply with requirements in Chapter 21 of the North Carolina Building Code.
 1. Place reinforcement as indicated.
- C. Clean reinforcement of loose rust, mill scale, earth, ice, or other materials, which will reduce bond to mortar or grout.
- D. Grouting: Do not place grout until entire height of masonry to be grouted has attained enough strength to resist grout pressure.
 1. Comply with requirements in Chapter 21 of the North Carolina Building Code for cleanouts and for grout placement, including minimum grout space and maximum pour height.
 2. At Contractor's option, use either low lift or high lift grouting techniques subject to requirements.
 3. Prior to placing grout, visually inspect and clean out grout cavities.
 4. Place vertical reinforcement before grouting.
 5. Limit height of vertical grout pours to not more than 60 inches

3.11 FIELD QUALITY CONTROL

- A. Inspectors: Owner will engage qualified independent inspectors to perform inspections and prepare reports. Allow inspectors access to scaffolding and work areas, as needed to perform inspections.
 - 1. Place grout only after inspectors have verified compliance of grout spaces and grades, sizes, and locations of reinforcement.
- B. Testing Agency: Owner will engage a qualified independent testing and inspecting agency to perform field tests and inspections indicated below and prepare test reports:
 - 1. Payment for these services will be made by Owner.
 - 2. Retesting of materials failing to comply with specified requirements shall be done at Contractor's expense.
- C. Testing Frequency: One set of tests for each 5000 sq. ft. of wall area or portion thereof.
- D. Clay Masonry Unit Test: For each type of unit provided, per ASTM C 67.
- E. Concrete Masonry Unit Test: For each type of unit provided, per ASTM C 140.
- F. Mortar Test (Property Specification): For each mix provided, per ASTM C 780. Test mortar for mortar air content and compressive strength.
- G. Grout Test (Compressive Strength): For each mix provided, per ASTM C 1019.
- H. Prism Test: For each type of construction provided, per ASTM C 1314

3.12 REPAIRING, POINTING, AND CLEANING

- A. Remove and replace masonry units that are loose, chipped, broken, stained, or otherwise damaged or that do not match adjoining units. Install new units to match adjoining units; install in fresh mortar, pointed to eliminate evidence of replacement.
- B. Pointing: During the tooling of joints, enlarge voids and holes, except weep holes, and completely fill with mortar. Point up joints, including corners, openings, and adjacent construction, to provide a neat, International appearance. Prepare joints for sealant application, where indicated.
- C. In-Progress Cleaning: Clean unit masonry as work progresses by dry brushing to remove mortar fins and smears before tooling joints.
- D. Final Cleaning: After mortar is thoroughly set and cured, clean exposed masonry as follows:
 - 1. Remove large mortar particles by hand with wooden paddles and nonmetallic scrape hoes or chisels.
 - 2. If requested by Architect, test cleaning methods on sample wall panel; leave one-half of panel un-cleaned for comparison purposes. Obtain Architect's approval of sample cleaning before proceeding with cleaning of masonry.

3. Protect adjacent stone and non-masonry surfaces from contact with cleaner by covering them with liquid strippable masking agent or polyethylene film and waterproof masking tape.
4. Saturate wall surfaces with water before applying cleaners; remove cleaners promptly by rinsing surfaces thoroughly with clear water.
5. Clean brick by bucket-and-brush hand-cleaning method described in BIA Technical Notes 20.
6. Clean masonry with a proprietary acidic cleaner applied according to manufacturer's written instructions.
7. Clean concrete masonry by cleaning method indicated in NCMA TEK 8-2A applicable to type of stain on exposed surfaces.
8. Clean stone trim to comply with stone supplier's written instructions.

3.13 MASONRY WASTE DISPOSAL

- A. Salvageable Materials: Unless otherwise indicated, excess masonry materials are Contractor's property. At completion of unit masonry work, remove from Project site.

END OF SECTION 042210

SECTION 047200 - CAST STONE

PART 1 - GENERAL

1.1 RELATED DOCUMENTS

- A. Drawings and general provisions of the Contract, including General and Supplementary Conditions and Division 1 Specification Sections, apply to this Section.

1.2 SUMMARY

- A. This Section includes the following:

- 1. Cast stone trim including the following:

- a. Sills
- b. Coping
- c. Caps

- B. Related Sections include the following:

- 1. Division 4 Section "Unit Masonry Assemblies" for installing cast stone units in unit masonry.
- 2. Division 7 Section, "Joint Sealants" for sealing joints in cast stone.

1.3 SYSTEM DESCRIPTION

- A. General: Design, fabricate and install cast stone work to withstand normal loads from wind, gravity, movement of building structure, and thermally induced movement, as well as to resist deterioration under conditions of normal use including exposure to weather, without failure.

- 1. Design, fabricate and install cast stone anchoring system which results in attachments developing the capability to sustain the following forces generated by the supporting element (individual member or assembly) acting separately, based on the yield strength of the materials.
- 2. Anchors for Rigidly Suspended Cast Stone:
 - a. A total force of 2 times the dead weight of the element supported, applied vertically downward through the element's center of gravity, combined with loads caused by thermal movements.
 - b. A total force of 2 times the dead weight of the element supported, applied horizontally outward through the center of gravity of the element, combined with loads caused by thermal movement.

1.4 DEFINITIONS

- A. Cast Stone: Architectural precast concrete building units intended to simulate building stone trim units.

1.5 SUBMITTALS

- A. Product Data: Include construction details, material descriptions, dimensions of individual components and profiles, and finishes for cast stone units.
 - 1. Submit technical data for each type of cast stone, stonework accessory, stonework anchors, and other manufactured products as applicable to the cast stone installation.
- B. Shop Drawings: Show fabrication and installation details for cast stone units. Include dimensions, details of reinforcement and anchorages if any, and indication of finished faces.
 - 1. Include building elevations showing layout of units and locations of joints and anchors.
 - 2. Do not proceed with casting until shop drawings are approved and returned to Contractor.
- C. Samples for Verification:
 - 1. For each color and texture of cast stone required, 12 inches square in size.
 - 2. Include 2 or more samples of each type, color, or finish showing full range of expected variation in the completed work.
- D. Mockup Samples: Furnish full depth units from mix designs selected from initial samples. Provide units specified for installation in mockups as required for mockups in Division 4, "Unit Masonry Assemblies."
- E. Anchoring systems: Provide 3 sets
- F. Qualification Data: For manufacturer:
 - 1. Include copies of material test reports for completed projects, indicating compliance of cast stone with ASTM C 1364.

1.6 QUALITY ASSURANCE

- A. Manufacturer Qualifications: A qualified manufacturer of cast stone units with a minimum of 5 years experience in the production of units similar to those indicated for this Project, with sufficient production capacity to manufacture required units.
- B. Source Limitations for Cast Stone: Obtain cast stone units through one source from a single manufacturer.
- C. Source Limitations for Mortar Materials: Obtain mortar ingredients of a uniform quality, including color, from one manufacturer for each cementitious component and from one source or producer for each aggregate.

1.7 DELIVERY, STORAGE, AND HANDLING

- A. Coordinate delivery of cast stone with unit masonry work (when applicable) to minimize the need for on-site storage and to avoid delaying the Work.
- B. Pack, handle, and ship cast stone units in suitable packs or pallets.

1. Lift with wide-belt slings; do not use wire rope or ropes that might cause staining. Move cast stone units, if required, using dollies with wood supports.
 2. Store cast stone units on wood skids or pallets with non-staining, waterproof covers. Arrange to distribute weight evenly and to prevent damage to units. Ventilate under covers to prevent condensation.
- C. Store installation materials on elevated platforms, under cover, and in a dry location.
- D. Store mortar aggregates where grading and other required characteristics can be maintained, and contamination can be avoided.
- E. Deliver to project in undamaged condition.
- 1.8 PROJECT CONDITIONS
- A. Cold-Weather Requirements: Do not use frozen materials or materials mixed or coated with ice or frost. Do not build on frozen substrates. Comply with cold-weather construction requirements contained in ACI 530.1/ASCE 6/TMS 602.
1. Cold-Weather Cleaning: Use liquid cleaning methods only when air temperature is 40 deg F and above and will remain so until cast stone has dried, but not less than 7 days after completing cleaning.
- B. Hot-Weather Requirements: Comply with hot-weather construction requirements contained in ACI 530.1/ASCE 6/TMS 602.
- C. On site protections: Cover tops of wall with non-staining waterproof sheeting at the end of the day's work. Cover partially completed structures when work is not in progress. Extend cover a minimum of 24" down both sides and hold securely in place.
1. Prevent staining of cast stone from mortar, grout, sealants and other sources. Immediately remove such materials from stone with damage to latter.
 2. Protect base of walls from rain-splashed mud and mortar splatter by means of coverings spread on ground and over wall surface.
 3. Protect sills, ledges, and projections from mortar and sealant droppings.

PART 2 - PRODUCTS

2.1 MANUFACTURERS

- A. In other Part 2 articles where titles below introduce lists, the following requirements apply to product selection:
1. Products: Subject to compliance with requirements, provide one of the products specified.
 2. Manufacturers: Subject to compliance with requirements, provide products by one of the manufacturers specified.

2.2 CAST STONE MATERIALS

- A. General: Comply with ASTM C 1364 and the following:

- B. Portland Cement: ASTM C 150, Type I, containing not more than 0.60 percent total alkali when tested according to ASTM C 114.
 - 1. Type III cement may be used for cold-weather construction.
- C. Coarse Aggregates: Granite, quartz, or limestone complying with ASTM C 33; gradation as needed to produce required textures and colors as needed to produce required cast stone colors.
- D. Fine Aggregates: Carefully graded and washed natural sand or crushed stone complying with ASTM C 33, except gradation may vary as needed to produce required textures and colors as needed to produce required cast stone colors.
- E. Color Pigment: ASTM C 979, synthetic mineral-oxide pigments; color stable, free of carbon black, nonfading, and resistant to lime and other alkalis.
 - 1. The amount of pigment shall not exceed 10% by weight of cement used.
- F. Admixtures: Do not use admixtures unless specified or approved in writing by Architect. If approved, admixtures to meet the following requirements:
 - 1. Do not use admixtures that contain more than 0.1 percent water-soluble chloride ions by mass of cementitious materials. Do not use admixtures containing calcium chloride.
 - 2. Use only admixtures that are certified by manufacturer to be compatible with cement and other admixtures used.
 - 3. Air-Entraining Admixture: ASTM C 260.
 - 4. Water-Reducing Admixture: ASTM C 494/C 494M, Type A.
 - 5. Water-Reducing, Retarding Admixture: ASTM C 494/C 494M, Type D.
 - 6. Water-Reducing, Accelerating Admixture: ASTM C 494/C 494M, Type E.
- G. Reinforcement: Deformed steel bars complying with ASTM A 615/A 615M. Use galvanized or epoxy-coated reinforcement when covered with less than 1-1/2 inches of cast stone material.
 - 1. Galvanized Coating: ASTM A 767/A 767M.
- H. Cast stone anchors and attachments
 - 1. Provide anchors and attachments of type and size required to support cast stone work and fabricated from the following metals for conditions and anchors indicated below. Provide only anchors and anchor fasteners or attachment methods that are compatible with all materials they contact, such that galvanic corrosion is prevented.

2.3 CAST STONE UNITS

- A. Manufacturers: Subject to compliance with requirements, provide one of the following, or approved equal product:
 - 1. Advanced Cast Stone, Inc.
 - 2. Architectural Ornamental Castings, Inc.
 - 3. Continental Cast Stone East; Russell, Inc.
 - 4. Edwards Cast Stone Company.
 - 5. Structural Stone, Inc. (wet cast).

- B. Provide cast stone units complying with ASTM C 1364 using the vibrant dry tamp or wet-cast method.
1. Provide units that are resistant to freezing and thawing as determined by laboratory testing according to ASTM C 666, Procedure A, as modified by ASTM C 1364, or are made from cast stone that has a history of successful resistance to freezing and thawing.
 2. Compressive strength shall be not less than 6500 psi at 28 days when tested in accordance with the requirements of this specification.
- C. Fabricate units with sharp arris and details accurately reproduced with indicated texture on all exposed surfaces, unless otherwise indicated.
1. Slope exposed horizontal surfaces 1:12, unless otherwise indicated.
 2. Provide raised fillets at backs of sills and at ends indicated to be built into jambs.
 3. Provide drips on projecting elements, unless otherwise indicated.
- D. Fabrication Tolerances:
1. Variation in Cross Section: Do not vary from indicated dimensions by more than plus 1/16 inch or minus 1/8 inch.
 2. Variation in Length: Do not vary from indicated dimensions by more than 1/360 of the length of unit or 1/8 inch, whichever is greater, but in no case by more than 3/16 inch.
 3. Warp, Bow, and Twist: Not to exceed 1/360 of the length of unit or 1/8 inch, whichever is greater.
 4. Location of Grooves, False Joints, Holes, Anchorages, and Similar Features: Do not vary from indicated position by more than 1/8 inch on formed surfaces of units and 3/8 inch on unformed surfaces.
- E. Cure units by one of the following methods:
1. Cure units with steam in enclosed curing room at temperature of 105 deg F or above and 95 to 100 percent relative humidity for 6 hours.
 2. Cure units with dense fog and water spray in enclosed warm curing room at 95 to 100 percent relative humidity for 24 hours.
 3. Cure units to comply with one of the following:
 - a. Not less than 5 days at mean daily temperature of 70 deg F or above.
 - b. Not less than 6 days at mean daily temperature of 60 deg F or above.
 - c. Not less than 7 days at mean daily temperature of 50 deg F or above.
 - d. Not less than 8 days at mean daily temperature of 45 deg F or above.
- F. Acid etch units after curing to remove cement film from surfaces to be exposed to view.
- G. Color and Texture: Provide units with fine-grained texture and buff color resembling Indiana limestone.
- 2.4 MORTAR MATERIALS
- A. Provide mortar materials that comply with Division 4 Section "Unit Masonry Assemblies."

2.5 ACCESSORIES

- A. Dowels in direct contact with cast stone: Round stainless-steel bars complying with ASTM A 276, Type 304, and 1/2-inch diameter.
- B. Dowels not in direct contact with cast stone: Round steel bars complying with ASTM A 36/A 36M or ASTM A 615/A 615M, 1/2-inch diameter, and hot-dip galvanized to comply with ASTM A 123/A 123M.
- C. Proprietary Acidic Cleaner: Manufacturer's standard-strength, general-purpose cleaner designed for removing mortar/grout stains, efflorescence, and other construction stains from new masonry surfaces without discoloring or damaging masonry surfaces; expressly approved for intended use by cast stone manufacturer and expressly approved by cleaner manufacturer for use on cast stone and adjacent masonry materials.
 - 1. Manufacturers:
 - a. Diedrich Technologies, Inc.
 - b. EaCo Chem, Inc.
 - c. ProSoCo, Inc.
- D. Concealed Flashings: Comply with Division 4 "Unit Masonry Assemblies" or where not indicated, provide stainless steel flashings in compliance with ASTM A276 when in direct contact with cast stone.
 - 1. Other concealed flashings: Use 5 oz. composite flashing of copper laminated to glass fiber cloth. Use non-bituminous type where flashing is in contact with single ply membrane roofing.
- E. Cotton cord for weepholes: For changes in plane or where cast stone is acting as part of lintel assembly; Sash cord of length required for 2" exposure on exterior and 18" in cavity between cast stone and backup substrate(s).

2.6 MORTAR MIXES

- A. Comply with requirements in Division 4 Section "Unit Masonry Assemblies" for mortar mixes or when not indicated, ASTM C270, Proportion Specification for types of mortars specified herein.
- B. Do not use admixtures, including pigments, air-entraining agents, accelerators, retarders, water-repellent agents, antifreeze compounds, or other admixtures, unless otherwise indicated.
 - 1. Do not use calcium chloride in mortar.
 - 2. Limit cementitious materials in mortar to portland cement, mortar cement, and lime.
- C. Comply with ASTM C 270, Proportion Specification.
 - 1. For setting mortar, use Type N.
 - 2. For pointing mortar, use Type N.

2.7 SOURCE QUALITY CONTROL

- A. Employ an independent testing agency to sample and test cast stone units according to ASTM C 1364.
 - 1. Test results shall be determined by the average of three specimens per test.

PART 3 - EXECUTION

3.1 GENERAL

- A. Fabricate cast stone work in sizes and shapes to comply with requirements indicated, including details on Drawings and final shop drawings.
 - 1. Minor cutting of cast stone in the field will be allowed only if finished appearance of cut units is acceptable to the Architect. Unacceptable units shall be recast by manufacturer to the required dimensions.
- B. Fabricate cast stone with sinkages and holes in stone for anchors, fasteners, support and lifting devices as indicated or needed to set stonework securely in place; shape beds to fit supports.
- C. Fabricate cast stone to produce pieces of thickness, size and shape indicate or required within fabrication tolerances specified and to produce joints of uniform width and in location indicated.

3.2 EXAMINATION

- A. Examine substrates and conditions, with Installer present, for compliance with requirements for installation tolerances and other conditions affecting performance of cast stone.
 - 1. Proceed with installation only after unsatisfactory conditions have been corrected.

3.3 PREPARATION

- A. Advise installers of other Work about specific requirements related to the placing of inserts, flashing, reglets and similar items which will be used by the cast stone Installer for anchoring, supporting and flashing stone work. Furnish Installers of other work with drawings or templates showing location of these items.
- B. Clean cast stone surfaces which may have become dirty or stained prior to setting, to remove soil, stains and foreign materials. Cleans stones by thoroughly scrubbing stones with fiber brushes followed by a thorough drenching with clear water. Use on mild cleaning compounds that contain no caustic or harsh filler or abrasives.

3.4 SETTING WATERTABLES AND WALL CAPS

- A. Provide stainless steel cap flashing under cast stone caps, that continuously covers the entire top of wall with ½ inch 45-degree drip edging profile along outside wall face.
- B. Where pins or other insert type anchors are used to tie cast stone parapets to masonry or other wall types, seal all penetrations through cap flashings with an elastomeric sealant compatible with the flashing type.

- C. Parapet caps and wall cap joints between units shall be set with mortar, then raked back to a depth equal to the joint width and sealed with an elastomeric sealant in compliance with Division 07, Section "Joint Sealants."

3.5 INSTALLATION TOLERANCES

- A. Variation from Plumb: Do not exceed 1/8 inch in 10 feet, 1/4 inch in 20 feet, or 1/2 inch maximum.
- B. Variation from Level: Do not exceed 1/8 inch in 10 feet, 1/4 inch in 20 feet, or 1/2 inch maximum.
- C. Variation in Joint Width: Do not vary joint thickness more than 1/8 inch in 36 inches or one-fourth of nominal joint width, whichever is less.
- D. Variation in Plane between Adjacent Surfaces (Lipping): Do not vary from flush alignment with adjacent units or adjacent surfaces indicated to be flush with units by more than 1/16 inch, except due to warpage of units within tolerances specified.

3.6 ADJUSTING AND CLEANING

- A. Remove and replace stained, broken, chipped and otherwise damaged units and units not matching approved Samples. Cast stone may be repaired if methods and results are approved by the Architect.
- B. Replace units in a manner that results in cast stone matching approved Samples, complying with other requirements, and showing no evidence of replacement.
- C. In-Progress Cleaning: Clean cast stone as work progresses.
 - 1. Remove mortar fins and smears before tooling joints.
 - 2. Remove excess sealant immediately, including spills, smears, and spatter.
- D. Final Cleaning: Not less than 6 days after completion of work, clean exposed cast stone as follows:
 - 1. Remove large mortar particles by hand with wooden paddles and nonmetallic scrape hoes or chisels.
 - 2. Test cleaning methods on sample; leave one sample uncleaned for comparison purposes. Obtain Architect's approval of sample cleaning before proceeding with cleaning of cast stone.
 - 3. Protect adjacent surfaces from contact with cleaner by covering them with liquid strippable masking agent or polyethylene film and waterproof masking tape.
 - 4. Completely soak surfaces with water before applying cleaners; remove cleaners promptly by rinsing thoroughly with clear water.
 - 5. Saturate panels with clear water prior to beginning other types of masonry cleaning directly above the cast stone work.
 - 6. Clean cast stone by bucket-and-brush hand-cleaning method described in BIA Technical Notes No. 20.

7. Clean cast stone with proprietary acidic cleaner applied according to manufacturer's written instructions.

END OF SECTION 047200

DIVISION 5 – METALS – STRUCTURAL STEEL SUMMARY OF WORK - SEAL SHEET

Structural Steel Work – Division 5 – Metals

Structural Steel Framing work shall be defined as Section 051200

Steel Joist Framing work shall be defined as Section 052100

Steel Decking work shall be defined as Section 053100



Divisions, 5 – Metals – Structural Steel Summary of Work

Structural Engineer

Adam Sisk, PE, SE

Woods Engineering, PA

254 N Front St. Suite 201

Wilmington, NC 28401

(910) 343-8007

SECTION 051200 - STRUCTURAL STEEL FRAMING

PART 1 - GENERAL

1.1 RELATED DOCUMENTS

- A. Drawings and general provisions of the Contract, including General and Supplementary Conditions and Division 01 Specification Sections, apply to this Section.

1.2 SUMMARY

A. Section Includes:

1. Structural steel.
2. Grout.

B. Related Sections:

1. Section 014000 "Quality Requirements" for independent testing agency procedures and administrative requirements.
2. Section 053100 "Steel Decking".
3. Section 055000 "Metal Fabrications" for miscellaneous steel fabrications not defined as structural steel.
4. Section 099113 "Exterior Painting" and Section 099123 "Interior Painting" for surface-preparation and priming requirements.

1.3 DEFINITIONS

- A. Structural Steel: Elements of structural-steel frame, as classified by AISC 303, "Code of Standard Practice for Steel Buildings and Bridges."

1.4 PERFORMANCE REQUIREMENTS

- A. Connections: Provide details of simple shear connections required by the Contract Documents to be selected or completed by structural-steel fabricator, including comprehensive engineering analysis by a qualified professional engineer, to withstand loads indicated and comply with other information and restrictions indicated.

1. Select and complete connections using schematic details indicated and AISC 360.
2. Use LRFD; data are given at factored-load level.

- B. Construction: Steel Braced Frames

1.5 ACTION SUBMITTALS

- A. Product Data: For each type of product indicated.

- B. Shop Drawings: Show fabrication of structural-steel components.

1. Include details of cuts, connections, splices, camber, holes, and other pertinent data.
2. Include embedment drawings.

3. Indicate welds by standard AWS symbols, distinguishing between shop and field welds, and show size, length, and type of each weld. Show backing bars that are to be removed and supplemental fillet welds where backing bars are to remain.
 4. Indicate type, size, and length of bolts, distinguishing between shop and field bolts.
 5. Identify demand critical welds.
 6. For structural-steel connections indicated to comply with design loads, include structural analysis data signed and sealed by the qualified professional engineer responsible for their preparation.
- C. Welding Procedure Specifications (WPSs) and Procedure Qualification Records (PQRs): Provide according to AWS D1.1/D1.1M, "Structural Welding Code - Steel," for each welded joint whether prequalified or qualified by testing, including the following:
1. Power source (constant current or constant voltage).
 2. Electrode manufacturer and trade name, for demand critical welds.

1.6 INFORMATIONAL SUBMITTALS

- A. Qualification Data: For qualified Installer, fabricator, professional engineer and testing agency.
- B. Welding certificates.
- C. Paint Compatibility Certificates: From manufacturers of topcoats applied over shop primers, certifying that shop primers are compatible with topcoats.
- D. Mill test reports for structural steel, including chemical and physical properties.
- E. Product Test Reports: For the following:
 1. Bolts, nuts, and washers including mechanical properties and chemical analysis.
 2. Shop primers.
 3. Nonshrink grout.
- F. Source quality-control reports.

1.7 QUALITY ASSURANCE

- A. Fabricator Qualifications: A qualified fabricator that participates in the AISC Quality Certification Program and is designated an AISC-Certified Plant, Category STD.
- B. Installer Qualifications: A qualified installer who participates in the AISC Quality Certification Program and is designated an AISC-Certified Erector, Category ACSE.
- C. Welding Qualifications: Qualify procedures and personnel according to AWS D1.1/D1.1M, "Structural Welding Code - Steel."
 1. Welders and welding operators performing work on bottom-flange, demand-critical welds shall pass the supplemental welder qualification testing, as required by AWS D1.8. FCAW-S and FCAW-G shall be considered separate processes for welding personnel qualification.
- D. Comply with applicable provisions of the following specifications and documents:
 1. AISC 303.
 2. AISC 341 and AISC 341s1.

3. AISC 360.
4. RCSC's "Specification for Structural Joints Using ASTM A 325 or A 490 Bolts."

E. Preinstallation Conference: Conduct conference at Project site.

1.8 DELIVERY, STORAGE, AND HANDLING

A. Store materials to permit easy access for inspection and identification. Keep steel members off ground and spaced by using pallets, dunnage, or other supports and spacers. Protect steel members and packaged materials from corrosion and deterioration.

1. Do not store materials on structure in a manner that might cause distortion, damage, or overload to members or supporting structures. Repair or replace damaged materials or structures as directed.

B. Store fasteners in a protected place in sealed containers with manufacturer's labels intact.

1. Fasteners may be repackaged provided Owner's testing and inspecting agency observes repackaging and seals containers.
2. Clean and relubricate bolts and nuts that become dry or rusty before use.
3. Comply with manufacturers' written recommendations for cleaning and lubricating ASTM F 1852 fasteners and for retesting fasteners after lubrication.

1.9 COORDINATION

A. Coordinate selection of shop primers with topcoats to be applied over them. Comply with paint and coating manufacturers' recommendations to ensure that shop primers and topcoats are compatible with one another.

B. Coordinate installation of anchorage items to be embedded in or attached to other construction without delaying the Work. Provide setting diagrams, sheet metal templates, instructions, and directions for installation.

PART 2 - PRODUCTS

2.1 STRUCTURAL-STEEL MATERIALS

A. Recycled Content of Steel Products: Postconsumer recycled content plus one-half of preconsumer recycled content not less than 25 percent.

B. W-Shapes: ASTM A 992/A 992M.

C. Channels and Angles: ASTM A 36/A 36M.

D. Plate and Bar: ASTM A 36/A 36M.

E. Cold-Formed Hollow Structural Sections: ASTM A 500, Grade B, structural tubing.

F. Steel Pipe: ASTM A 53/A 53M, Type E or S, Grade B.

1. Weight Class: Standard unless noted otherwise.
2. Finish: Black except where indicated to be galvanized.

G. Welding Electrodes: Comply with AWS requirements.

2.2 BOLTS, CONNECTORS, AND ANCHORS

- A. High-Strength Bolts, Nuts, and Washers: ASTM A 325 (ASTM A 325M), Type 1, heavy-hex steel structural bolts; ASTM A 563, Grade C, (ASTM A 563M, Class 8S) heavy-hex carbon-steel nuts; and ASTM F 436 (ASTM F 436M), Type 1, hardened carbon-steel washers; all with plain finish.
- B. High-Strength Bolts, Nuts, and Washers: ASTM A 490 (ASTM A 490M), Type 1, heavy-hex steel structural bolts; ASTM A 563, Grade DH, (ASTM A 563M, Class 10S) heavy-hex carbon-steel nuts; and ASTM F 436 (ASTM F 436M), Type 1, hardened carbon-steel washers with plain finish.
- C. Shear Connectors: ASTM A 108, Grades 1015 through 1020, headed-stud type, cold-finished carbon steel; AWS D1.1/D1.1M, Type B.
- D. Unheaded Anchor Rods: ASTM F 1554, Grade 36.
 - 1. Configuration: Straight.
 - 2. Nuts: ASTM A 563 (ASTM A 563M) heavy-hex carbon steel.
 - 3. Plate Washers: ASTM A 36/A 36M carbon steel.
 - 4. Washers: ASTM F 436 (ASTM F 436M), Type 1, hardened carbon steel.
 - 5. Finish: Plain.
- E. Headed Anchor Rods: ASTM F 1554, Grade 36, straight.
 - 1. Nuts: ASTM A 563 (ASTM A 563M) heavy-hex carbon steel.
 - 2. Plate Washers: ASTM A 36/A 36M carbon steel.
 - 3. Washers: ASTM F 436 (ASTM F 436M), Type 1, hardened carbon steel.
 - 4. Finish: Plain.
- F. Threaded Rods: ASTM A 36/A 36M.
 - 1. Nuts: ASTM A 563 (ASTM A 563M) heavy-hex carbon steel.
 - 2. Washers: ASTM F 436 (ASTM F 436M), Type 1, hardened carbon steel.
 - 3. Finish: Plain.

2.3 PRIMER

- A. Primer: Fabricator's standard lead- and chromate-free, nonasphaltic, rust-inhibiting primer complying with MPI#79 and compatible with topcoat.
- B. Galvanizing Repair Paint: ASTM A 780.

2.4 GROUT

- A. Nonmetallic, Shrinkage-Resistant Grout: ASTM C 1107, factory-packaged, nonmetallic aggregate grout, noncorrosive and nonstaining, mixed with water to consistency suitable for application and a 30-minute working time.

2.5 FABRICATION

- A. Structural Steel: Fabricate and assemble in shop to greatest extent possible. Fabricate according to AISC's "Code of Standard Practice for Steel Buildings and Bridges" and AISC 360.

1. Camber structural-steel members where indicated.
 2. Fabricate beams with rolling camber up.
 3. Identify high-strength structural steel according to ASTM A 6/A 6M and maintain markings until structural steel has been erected.
 4. Mark and match-mark materials for field assembly.
 5. Complete structural-steel assemblies, including welding of units, before starting shop-priming operations.
- B. Thermal Cutting: Perform thermal cutting by machine to greatest extent possible.
1. Plane thermally cut edges to be welded to comply with requirements in AWS D1.1/D1.1M.
- C. Bolt Holes: Cut, drill or punch standard bolt holes perpendicular to metal surfaces.
- D. Finishing: Accurately finish ends of columns and other members transmitting bearing loads.
- E. Cleaning: Clean and prepare steel surfaces that are to remain unpainted according to SSPC-SP 1, "Solvent Cleaning."
- F. Shear Connectors: Prepare steel surfaces as recommended by manufacturer of shear connectors. Use automatic end welding of headed-stud shear connectors according to AWS D1.1/D1.1M and manufacturer's written instructions.
- G. Welded Door Frames: Build up welded door frames attached to structural steel. Weld exposed joints continuously and grind smooth. Plug-weld fixed steel bar stops to frames. Secure removable stops to frames with countersunk machine screws, uniformly spaced not more than 10 inches o.c. unless otherwise indicated.
- H. Holes: Provide holes required for securing other work to structural steel and for other work to pass through steel framing members.
1. Cut, drill, or punch holes perpendicular to steel surfaces. Do not thermally cut bolt holes or enlarge holes by burning.
 2. Baseplate Holes: Cut, drill, mechanically thermal cut, or punch holes perpendicular to steel surfaces.
 3. Weld threaded nuts to framing and other specialty items indicated to receive other work.

2.6 SHOP CONNECTIONS

- A. High-Strength Bolts: Shop install high-strength bolts according to RCSC's "Specification for Structural Joints Using ASTM A 325 or A 490 Bolts" for type of bolt and type of joint specified.
1. Joint Type: Snug tightened.
- B. Weld Connections: Comply with AWS D1.1/D1.1M for tolerances, appearances, welding procedure specifications, weld quality, and methods used in correcting welding work.
1. Assemble and weld built-up sections by methods that will maintain true alignment of axes without exceeding tolerances in AISC 303 for mill material.

2.7 SOURCE QUALITY CONTROL

- A. Fabricator Qualifications: A qualified fabricator that participates in the AISC Quality Certification Program and is designated an AISC-Certified Plant, Category STD.

- B. The Fabricator shall be a designated AISC-Certified Plant, Category STD or the Fabricator at their expense shall engage an independent testing and inspecting agency to perform shop tests and inspections and prepare test reports, this expense shall be added to the Non-Certified Fabricator's bid.
 - 1. Provide testing agency with access to places where structural-steel work is being fabricated or produced to perform tests and inspections.
- C. Correct deficiencies in Work that test reports and inspections indicate does not comply with the Contract Documents.
- D. Bolted Connections: Shop-bolted connections will be inspected according to RCSC's "Specification for Structural Joints Using ASTM A 325 or A 490 Bolts."
- E. Welded Connections: In addition to visual inspection, shop-welded connections will be tested and inspected according to AWS D1.1/D1.1M and the following inspection procedures, at testing agency's option:
 - 1. Liquid Penetrant Inspection: ASTM E 165.
 - 2. Magnetic Particle Inspection: ASTM E 709; performed on root pass and on finished weld. Cracks or zones of incomplete fusion or penetration will not be accepted.
 - 3. Ultrasonic Inspection: ASTM E 164.
 - 4. Radiographic Inspection: ASTM E 94.

2.8 SHOP PRIMING

- A. Shop prime steel surfaces except the following:
 - 1. Surfaces embedded in concrete or mortar. Extend priming of partially embedded members to a depth of 2 inches (50 mm).
 - 2. Surfaces to be field welded.
 - 3. Galvanized surfaces.
- B. Surface Preparation: Clean surfaces to be painted. Remove loose rust and mill scale and spatter, slag, or flux deposits. Prepare surfaces according to the following specifications and standards:
 - 1. SSPC-SP 2, "Hand Tool Cleaning."
 - 2. SSPC-SP 3, "Power Tool Cleaning."
- C. Priming: Immediately after surface preparation, apply primer according to manufacturer's written instructions and at rate recommended by SSPC to provide a minimum dry film thickness of 1.5 mils (0.038 mm). Use priming methods that result in full coverage of joints, corners, edges, and exposed surfaces.

2.9 GALVANIZING

- A. Hot-Dip Galvanized Finish: Apply zinc coating by the hot-dip process to structural steel according to ASTM A 123/A 123M.
 - 1. Fill vent and drain holes that will be exposed in the finished Work unless they will function as weep holes, by plugging with zinc solder and filing off smooth.

2. Galvanize all building columns, lintels and shelf angles.

PART 3 - EXECUTION

3.1 EXAMINATION

- A. Verify, with steel Erector present, elevations of concrete- and masonry-bearing surfaces and locations of anchor rods, bearing plates, and other embedments for compliance with requirements.
 1. Prepare a certified survey of bearing surfaces, anchor rods, bearing plates, and other embedments showing dimensions, locations, angles, and elevations.
- B. Proceed with installation only after unsatisfactory conditions have been corrected.

3.2 PREPARATION

- A. Provide temporary shores, guys, braces, and other supports during erection to keep structural steel secure, plumb, and in alignment against temporary construction loads and loads equal in intensity to design loads. Remove temporary supports when permanent structural steel, connections, and bracing are in place unless otherwise indicated.

3.3 ERECTION

- A. Set structural steel accurately in locations and to elevations indicated and according to AISC 303 and AISC 360.
- B. Base Bearing Plates: Clean concrete- and masonry-bearing surfaces of bond-reducing materials, and roughen surfaces prior to setting plates. Clean bottom surface of plates.
 1. Set plates for structural members on wedges, shims, or setting nuts as required.
 2. Weld plate washers to top of baseplate, where indicated.
 3. Snug-tighten anchor rods after supported members have been positioned and plumbed. Do not remove wedges or shims but, if protruding, cut off flush with edge of plate before packing with grout.
 4. Promptly pack grout solidly between bearing surfaces and plates so no voids remain. Neatly finish exposed surfaces; protect grout and allow to cure. Comply with manufacturer's written installation instructions for shrinkage-resistant grouts.
- C. Maintain erection tolerances of structural steel within AISC's "Code of Standard Practice for Steel Buildings and Bridges."
- D. Align and adjust various members that form part of complete frame or structure before permanently fastening. Before assembly, clean bearing surfaces and other surfaces that will be in permanent contact with members. Perform necessary adjustments to compensate for discrepancies in elevations and alignment.
 1. Level and plumb individual members of structure.
 2. Make allowances for difference between temperature at time of erection and mean temperature when structure is completed and in service.
- E. Splice members only where indicated.
- F. Do not use thermal cutting during erection.

- G. Do not enlarge unfair holes in members by burning or using drift pins. Ream holes that must be enlarged to admit bolts.
- H. Shear Connectors: Prepare steel surfaces as recommended by manufacturer of shear connectors. Use automatic end welding of headed-stud shear connectors according to AWS D1.1/D1.1M and manufacturer's written instructions.

3.4 FIELD CONNECTIONS

- A. High-Strength Bolts: Install high-strength bolts according to RCSC's "Specification for Structural Joints Using ASTM A 325 or A 490 Bolts" for type of bolt and type of joint specified.
 - 1. Joint Type: Snug tightened unless otherwise indicated.
- B. Weld Connections: Comply with AWS D1.1/D1.1M for tolerances, appearances, welding procedure specifications, weld quality, and methods used in correcting welding work.
 - 1. Comply with AISC 303 and AISC 360 for bearing, alignment, adequacy of temporary connections, and removal of paint on surfaces adjacent to field welds.
 - 2. Remove backing bars or runoff tabs where indicated, back gouge, and grind steel smooth.
 - 3. Assemble and weld built-up sections by methods that will maintain true alignment of axes without exceeding tolerances in AISC's "Code of Standard Practice for Steel Buildings and Bridges" for mill material.

3.5 FIELD QUALITY CONTROL

- A. Testing Agency: Owner will engage a qualified independent testing and inspecting agency to inspect field welds and high-strength bolted connections.
- B. Bolted Connections: Bolted connections will be inspected according to RCSC's "Specification for Structural Joints Using ASTM A 325 or A 490 Bolts."
- C. Welded Connections: Field welds will be visually inspected according to AWS D1.1/D1.1M.
 - 1. In addition to visual inspection, field welds will be tested and inspected according to AWS D1.1/D1.1M and the following inspection procedures, at testing agency's option:
 - a. Liquid Penetrant Inspection: ASTM E 165.
 - b. Magnetic Particle Inspection: ASTM E 709; performed on root pass and on finished weld. Cracks or zones of incomplete fusion or penetration will not be accepted.
 - c. Ultrasonic Inspection: ASTM E 164.
 - d. Radiographic Inspection: ASTM E 94.
- D. In addition to visual inspection, test and inspect field-welded shear connectors according to requirements in AWS D1.1/D1.1M for stud welding and as follows:
 - 1. Perform bend tests if visual inspections reveal either a less-than-continuous 360-degree flash or welding repairs to any shear connector.
 - 2. Conduct tests on additional shear connectors if weld fracture occurs on shear connectors already tested, according to requirements in AWS D1.1/D1.1M.
- E. Correct deficiencies in Work that test reports and inspections indicate does not comply with the Contract Documents.

3.6 REPAIRS AND PROTECTION

- A. Galvanized Surfaces: Clean areas where galvanizing is damaged or missing and repair galvanizing to comply with ASTM A 780.
- B. Touchup Painting: Cleaning and touchup painting are specified in Section 099113 "Exterior Painting" and Section 099123 "Interior Painting."

END OF SECTION 051200

SECTION 052100 - STEEL JOIST FRAMING

PART 1 GENERAL

1.1 RELATED DOCUMENTS

- A. Drawings and general provisions of the Contract, including General and Supplementary Conditions and Division 01 Specification Sections, apply to this Section.

1.2 SUMMARY

- A. Section Includes:
 - 1. K-series steel joists.
 - 2. KCS-type K-series steel joists.
 - 3. K-series steel joist substitutes.
 - 4. Joist accessories.

1.3 DEFINITIONS

- A. SJI's "Specifications": Steel Joist Institute's "Standard Specifications, Load Tables and Weight Tables for Steel Joists and Joist Girders."

1.4 ACTION SUBMITTALS

- A. Product Data: For each type of joist, accessory, and product.
- B. Shop Drawings:
 - 1. Include layout, designation, number, type, location, and spacing of joists.
 - 2. Include joining and anchorage details, bracing, bridging, and joist accessories; splice and connection locations and details; and attachments to other construction.
 - 3. Indicate locations and details of bearing plates to be embedded in other construction.

1.5 INFORMATIONAL SUBMITTALS

- A. Qualification Data: For manufacturer and professional engineer.
- B. Manufacturer certificates.
- C. Mill Certificates: For each type of bolt.
- D. Comprehensive engineering analysis of special joists signed and sealed by the qualified professional engineer responsible for its preparation.

1.6 QUALITY ASSURANCE

- A. Manufacturer Qualifications: A manufacturer certified by SJI to manufacture joists complying with applicable standard specifications and load tables in SJI's "Specifications."
 - 1. Manufacturer's responsibilities include providing professional engineering services for designing special joists to comply with performance requirements.
- B. Welding Qualifications: Qualify field-welding procedures and personnel according to AWS D1.1/D1.1M, "Structural Welding Code - Steel."

1.7 DELIVERY, STORAGE, AND HANDLING

- A. Deliver, store, and handle joists as recommended in SJI's "Specifications."
- B. Protect joists from corrosion, deformation, and other damage during delivery, storage, and handling.

PART 2 PRODUCTS

2.1 PERFORMANCE REQUIREMENTS

- A. Structural Performance: Provide special joists and connections capable of withstanding design loads indicated.
 - 1. Use ASD; data are given at service-load level.
 - 2. Design special joists to withstand design loads with live-load deflections no greater than the following:
 - 3. Roof Joists: Vertical deflection of 1/240 of the span.
- B. Recycled Content of Steel Products: Postconsumer recycled content plus one-half of preconsumer recycled content not less than 25 percent.

2.2 K-SERIES STEEL JOISTS

- A. Manufacture steel joists of type indicated according to "Standard Specifications for Open Web Steel Joists, K-Series" in SJI's "Specifications," with steel-angle top- and bottom-chord members, underslung ends, and parallel top chord.
 - 1. Joist Type: K-series steel joists and KCS-type K-series steel joists.
- B. Steel Joist Substitutes: Manufacture according to "Standard Specifications for Open Web Steel Joists, K-Series" in SJI's "Specifications," with steel-angle or -channel members.
- C. Provide holes in chord members for connecting and securing other construction to joists.
- D. Extended Ends: Extend bearing ends of joists with SJI's Type R extended ends where indicated, complying with SJI's "Specifications."
- E. Camber joists according to SJI's "Specifications."
- F. Equip bearing ends of joists with manufacturer's standard beveled ends or sloped shoes if joist slope exceeds 1/4 inch per 12 inches (1:48).
- B. Provide holes in chord members for connecting and securing other construction to joists.
- C. Camber long-span steel joists according to SJI's "Specifications".

2.3 PRIMERS

- A. Primer: SSPC-Paint 15, or manufacturer's standard shop primer complying with performance requirements in SSPC-Paint 15.

2.4 JOIST ACCESSORIES

- A. Bridging: Provide bridging anchors and number of rows of horizontal or diagonal bridging of material, size, and type required by SJI's "Specifications for type of joist, chord size, spacing, and span. Furnish additional erection bridging if required for stability.
- B. Fabricate steel bearing plates from ASTM A 36/A 36M steel with integral anchorages of sizes and thicknesses indicated. Shop prime paint.
- C. Carbon-Steel Bolts and Threaded Fasteners: ASTM A 307, Grade A (ASTM F 568M, Property Class 4.6), carbon-steel, hex-head bolts and threaded fasteners; carbon-steel nuts; and flat, unhardened steel washers.
 - 1. Finish: Plain, uncoated.
- D. High-Strength Bolts, Nuts, and Washers: ASTM A 325 (ASTM A 325M), Type 1, heavy hex steel structural bolts; ASTM A 563 (ASTM A 563M) heavy hex carbon-steel nuts; and ASTM F 436 (ASTM F 436M) hardened carbon-steel washers.
 - 1. Finish: Plain.
- E. Welding Electrodes: Comply with AWS standards.
- F. Furnish miscellaneous accessories including splice plates and bolts required by joist manufacturer to complete joist assembly.

2.5 CLEANING AND SHOP PAINTING

- A. Clean and remove loose scale, heavy rust, and other foreign materials from fabricated joists and accessories by hand-tool cleaning, SSPC-SP 2 or power-tool cleaning, SSPC-SP 3.
- B. Apply one coat of shop primer to joists and joist accessories to be primed to provide a continuous, dry paint film not less than 1 mil (0.025 mm) thick.

PART 3 EXECUTION

3.1 EXAMINATION

- A. Examine supporting substrates, embedded bearing plates, and abutting structural framing for compliance with requirements for installation tolerances and other conditions affecting performance.
- B. Proceed with installation only after unsatisfactory conditions have been corrected.

3.2 INSTALLATION

- A. Do not install joists until supporting construction is in place and secured.
- B. Install joists and accessories plumb, square, and true to line; securely fasten to supporting construction according to SJI's "Specifications," joist manufacturer's written recommendations, and requirements in this Section.

1. Before installation, splice joists delivered to Project site in more than one piece.
 2. Space, adjust, and align joists accurately in location before permanently fastening.
 3. Install temporary bracing and erection bridging, connections, and anchors to ensure that joists are stabilized during construction.
- C. Field weld joists to supporting steel framework. Coordinate welding sequence and procedure with placement of joists. Comply with AWS requirements and procedures for welding, appearance and quality of welds, and methods used in correcting welding work.
- D. Bolt joists to supporting steel framework using carbon-steel bolts.
- E. Bolt joists to supporting steel framework using high-strength structural bolts. Comply with Research Council on Structural Connection's "Specification for Structural Joints Using ASTM A 325 or ASTM A 490 Bolts" for high-strength structural bolt installation and tightening requirements.
- F. Install and connect bridging concurrently with joist erection, before construction loads are applied. Anchor ends of bridging lines at top and bottom chords if terminating at walls or beams.

3.3 FIELD QUALITY CONTROL

- A. Testing Agency: Owner will engage a qualified independent testing and inspecting agency to inspect field welds and bolted connections and to perform field tests and inspections and prepare test and inspection reports.
- B. Visually inspect field welds according to AWS D1.1/D1.1M.
- C. Visually inspect bolted connections.
- D. Correct deficiencies in Work that test and inspection reports have indicated are not in compliance with specified requirements.
- E. Perform additional testing to determine compliance of corrected Work with specified requirements.

3.4 PROTECTION

- A. Touchup Painting: After installation, promptly clean, prepare, and prime or reprime field connections, rust spots, and abraded surfaces of prime-painted joists, bearing plates, abutting structural steel, and accessories.
1. Clean and prepare surfaces by hand-tool cleaning according to SSPC-SP 2, or power-tool cleaning according to SSPC-SP 3.
 2. Apply a compatible primer of same type as primer used on adjacent surfaces.

END OF SECTION 052100

SECTION 053100 - STEEL DECKING

PART 1 - GENERAL

1.1 RELATED DOCUMENTS

- A. Drawings and general provisions of the Contract, including General and Supplementary Conditions and Division 01 Specification Sections, apply to this Section.

1.2 SUMMARY

- A. Section Includes:

- 1. Roof deck.

- B. Related Requirements:

- 1. Division 051200 Section "Structural Steel Framing" for shop- and field-welded shear connectors.
 - 2. Section 055000 "Metal Fabrications" for framing deck openings with miscellaneous steel shapes.

1.3 ACTION SUBMITTALS

- A. Product Data: For each type of deck, accessory, and product indicated.

- B. Shop Drawings:

- 1. Include layout and types of deck panels, anchorage details, reinforcing channels, pans, cut deck openings, special jointing, accessories, and attachments to other construction.

1.4 INFORMATIONAL SUBMITTALS

- A. Welding certificates.

- B. Product Certificates: For each type of steel deck.

- C. Product Test Reports: Based on evaluation of comprehensive tests performed by a qualified testing agency, indicating that each of the following complies with requirements:

- 1. Power-actuated mechanical fasteners.

- D. Evaluation Reports: For steel deck.

- E. Field quality-control reports.

1.5 QUALITY ASSURANCE

- A. Testing Agency Qualifications: Qualified according to ASTM E 329 for testing indicated.
- B. Welding Qualifications: Qualify procedures and personnel according to AWS D1.3, "Structural Welding Code - Sheet Steel."

1.6 DELIVERY, STORAGE, AND HANDLING

- A. Protect steel deck from corrosion, deformation, and other damage during delivery, storage, and handling.
- B. Stack steel deck on platforms or pallets and slope to provide drainage. Protect with a waterproof covering and ventilate to avoid condensation.

PART 2 - PRODUCTS

2.1 PERFORMANCE REQUIREMENTS

- A. AISI Specifications: Comply with calculated structural characteristics of steel deck according to AISI's "North American Specification for the Design of Cold-Formed Steel Structural Members."
- B. Fire-Resistance Ratings: Comply with ASTM E 119; testing by a qualified testing agency. Identify products with appropriate markings of applicable testing agency.
 - 1. Indicate design designations from UL's "Fire Resistance Directory" or from the listings of another qualified testing agency.
- C. Recycled Content of Steel Products: Postconsumer recycled content plus one-half of preconsumer recycled content not less than 25 percent.

2.2 ROOF DECK

- A. Manufacturers: Subject to compliance with requirements, available manufacturers offering products that may be incorporated into the Work include, but are not limited to, the following:
 - 1. ASC Profiles, Inc.; a Blue Scope Steel company.
 - 2. Canam United States; Canam Group Inc.
 - 3. CMC Joist & Deck.
 - 4. Consolidated Systems, Inc.; Metal Dek Group.
 - 5. Cordeck.
 - 6. DACS, Inc.
 - 7. Epic Metals Corporation.
 - 8. Marlyn Steel Decks, Inc.
 - 9. New Millennium Building Systems, LLC.
 - 10. Nucor Corp.; Vulcraft Group.
 - 11. Roof Deck, Inc.
 - 12. Valley Joist; Subsidiary of EBSCO Industries, Inc.

13. Verco Manufacturing Co.
 14. Wheeling Corrugating Company; Div. of Wheeling-Pittsburgh Steel Corporation.
- B. Roof Deck: Fabricate panels, without top-flange stiffening grooves, to comply with "SDI Specifications and Commentary for Steel Roof Deck," in SDI Publication No. 31, and with the following:
1. Galvanized-Steel Sheet: ASTM A 653/A 653M, Structural Steel (SS), Grade 33 (230), G90 (Z275) zinc coating.
 2. Deck Profile: Type WR, wide rib.
 3. Profile Depth: 1-1/2 inches (38 mm).
 4. Design Uncoated-Steel Thickness: 0.0358 inches.
 5. Span Condition: Triple span or more.
 6. Side Laps: Overlapped or interlocking seam at Contractor's option.

2.3 ACCESSORIES

- A. General: Provide manufacturer's standard accessory materials for deck that comply with requirements indicated.
- B. Mechanical Fasteners: Corrosion-resistant, low-velocity, power-actuated or pneumatically driven stainless steel fasteners; or self-drilling, self-threading screws.
- C. Side-Lap Fasteners: Corrosion-resistant, hexagonal washer head; self-drilling, stainless steel screws, No. 10 (4.8-mm) minimum diameter.
- D. Flexible Closure Strips: Vulcanized, closed-cell, synthetic rubber.
- E. Miscellaneous Sheet Metal Deck Accessories: Steel sheet, minimum yield strength of 33,000 psi (230 MPa), not less than 0.0359-inch (0.91-mm) design uncoated thickness, of same material and finish as deck; of profile indicated or required for application.
- F. Pour Stops and Girder Fillers: Steel sheet, minimum yield strength of 33,000 psi (230 MPa), of same material and finish as deck, and of thickness and profile indicated.
- G. Column Closures, End Closures, Z-Closures, and Cover Plates: Steel sheet, of same material, finish, and thickness as deck unless otherwise indicated.
- H. Piercing Hanger Tabs: Piercing steel sheet hanger attachment devices for use with floor deck.
- I. Recessed Sump Pans: Single-piece steel sheet, 0.0747 inch (1.90 mm) thick, of same material and finish as deck, with 3-inch- (76-mm-) wide flanges and level recessed pans of 1-1/2-inch (38-mm) minimum depth. For drains, cut holes in the field.
- J. Galvanizing Repair Paint: ASTM A 780.

PART 3 - EXECUTION

3.1 EXAMINATION

- A. Examine supporting frame and field conditions for compliance with requirements for installation tolerances and other conditions affecting performance.
- B. Proceed with installation only after unsatisfactory conditions have been corrected.

3.2 INSTALLATION, GENERAL

- A. Install deck panels and accessories according to applicable specifications and commentary in SDI Publication No. 31, manufacturer's written instructions, and requirements in this Section.
- B. Install temporary shoring before placing deck panels if required to meet deflection limitations.
- C. Locate deck bundles to prevent overloading of supporting members.
- D. Place deck panels on supporting frame and adjust to final position with ends accurately aligned and bearing on supporting frame before being permanently fastened. Do not stretch or contract side-lap interlocks.
- E. Place deck panels flat and square and fasten to supporting frame without warp or deflection.
- F. Cut and neatly fit deck panels and accessories around openings and other work projecting through or adjacent to deck.
- G. Provide additional reinforcement and closure pieces at openings as required for strength, continuity of deck, and support of other work.
- H. Comply with AWS requirements and procedures for manual shielded metal arc welding, appearance and quality of welds, and methods used for correcting welding work.
- I. Mechanical fasteners may be used in lieu of welding to fasten deck. Locate mechanical fasteners and install according to deck manufacturer's written instructions.

3.3 ROOF-DECK INSTALLATION

- A. Fasten roof-deck panels to light gauge roof trusses or rafters with self-tapping TEK stainless steel screws as noted on plan.
- B. Fasten roof-deck panels to steel beams and steel bar joists with powder actuated fasteners as noted on plan.
- C. Side-Lap and Perimeter Edge Fastening: Fasten side laps and perimeter edges of panels between supports, at intervals not exceeding the lesser of 1/2 of the span or 36 inches (914 mm), or as noted on plans and as follows:

1. Mechanically fasten with self-drilling, No. 10 (4.8-mm-) diameter or larger, stainless steel screws.
- D. End Bearing: Install deck ends over supporting frame with a minimum end bearing of 1-1/2 inches (38 mm), with end joints as follows:
 1. End Joints: Lapped 2 inches (51 mm) minimum or butted at Contractor's option.
- E. Roof Sump Pans and Sump Plates: Install over openings provided in roof deck and mechanically fasten flanges to top of deck. Space mechanical fasteners not more than 12 inches (305 mm) apart with at least one fastener at each corner.
 1. Install reinforcing channels or zees in ribs to span between supports and mechanically fasten.
- F. Miscellaneous Roof-Deck Accessories: Install ridge and valley plates, finish strips, end closures, and reinforcing channels according to deck manufacturer's written instructions. Weld or mechanically fasten to substrate to provide a complete deck installation.
 1. Weld cover plates at changes in direction of roof-deck panels unless otherwise indicated.
- G. Flexible Closure Strips: Install flexible closure strips over partitions, walls, and where indicated. Install with adhesive according to manufacturer's written instructions to ensure complete closure.

3.4 CONTROL

- A. Testing Agency: Owner will engage a qualified testing agency to perform tests and inspections.
- B. Field welds will be subject to inspection.
- C. Testing agency will report inspection results promptly and in writing to Contractor and Architect.
- D. Remove and replace work that does not comply with specified requirements.
- E. Additional inspecting, at Contractor's expense, will be performed to determine compliance of corrected work with specified requirements.

3.5 PROTECTION

- A. Galvanizing Repairs: Prepare and repair damaged galvanized coatings on both surfaces of deck with galvanized repair paint according to ASTM A 780 and manufacturer's written instructions.
- B. Provide final protection and maintain conditions to ensure that steel deck is without damage or deterioration at time of Final Acceptance.

END OF SECTION 053100

SECTION 057300 - GLAZED DECORATIVE METAL RAILINGS

PART 1 - GENERAL

1.1 SUMMARY

- A. This Section includes the following:
1. Seamless weld stainless-steel ornamental handrails, guardrails, and railing systems with glass infill.
 2. Steel and iron ornamental railing.

1.2 PERFORMANCE REQUIREMENTS

- A. Structural Performance: Provide railings capable of withstanding the effects of gravity loads and the following loads and stresses within limits and under conditions indicated:

1. Handrails:
 - a. Uniform load of 50 lbf/ ft. applied in any direction.
 - b. Concentrated load of 200 lbf applied in any direction.
 - c. Uniform and concentrated loads need not be assumed to act concurrently.
2. Top Rails of Guards:
 - a. Uniform load of 50 lbf/ ft. applied in any direction.
 - b. Concentrated load of 200 lbf applied in any direction.
 - c. Uniform and concentrated loads need not be assumed to act concurrently.
3. Infill of Guards:
 - a. Concentrated load of 50 lbf applied horizontally on an area of 1 sq. ft.
 - b. Uniform load of 25 lbf/sq. ft. applied horizontally.
 - c. Infill load and other loads need not be assumed to act concurrently.

- B. Rail Tested per ASTM E 894-88 Standard Test Method for Anchorage of permanent Metal Railing Systems and Railing for Buildings.

E 935-93	Standard Test Methods for performance of Permanent Metal Railing Systems and Rails for Buildings.
E 985-93	Standard Specifications for Permanent Metal Railing Systems and Rails for Buildings.

- C. Thermal Action and Corrosion Control:

1. Allow for thermal action resulting from the maximum range change in ambient temperature in the design, fabrication, and installation of rail systems, to prevent opening of joints, buckling, and other detrimental effects, including over-stressing of connections and components.

2. Prevent galvanic action, and other forms of corrosion by isolating or insulating dissimilar metals to prevent them from being in direct contact with each other.
- D. Control of Corrosion: Prevent galvanic action and other forms of corrosion by insulating metals and other materials from direct contact with incompatible materials.

1.3 SUBMITTALS

- A. Product Data: For railings assembled from standard components, grout, anchoring cement, and paint products.
- B. Shop Drawings: Include plans, elevations, sections, details, and attachments to other Work.
1. For installed products indicated to comply with design loads, include structural analysis data signed and sealed by the qualified professional engineer responsible for their preparation.
- C. Samples: For each exposed finish required.
- D. Product Test Reports: Based on evaluation of comprehensive tests performed by a qualified testing agency, according to ASTM E 894 and ASTM E 935.

1.4 QUALITY ASSURANCE

- A. Product Options: Information on Drawings and in Specifications establishes requirements for system's aesthetic effects and performance characteristics. Do not modify intended aesthetic effects, as judged solely by Architect, except with Architect's approval.
1. Provide test specimens and assemblies representative of proposed materials and construction.
- B. Mockups: Build mockups to verify selections made under sample submittals and to demonstrate aesthetic effects and set quality standards for fabrication and installation.
1. Build mockups for each form and finish of railing consisting of two posts, top rail, infill area, and anchorage system components.
- C. Welding Certificates
- D. Qualified Installers: Installers shall be certified by the manufacturer and have 5 years successful in-service installations of similar systems, profile and scope to this project.

1.5 PROJECT CONDITIONS

- A. Field Measurements: Verify actual locations of walls and other construction contiguous with railings by field measurements before fabrication and indicate measurements on Shop Drawings.

1. Established Dimensions: Where field measurements cannot be made without delaying the Work, establish dimensions and proceed with fabricating railings without field measurements. Coordinate wall and other contiguous construction to ensure that actual dimensions correspond to established dimensions.
2. Provide allowance for trimming and fitting at site.

1.6 COORDINATION AND SCHEDULING

- A. Coordinate installation of anchorages for railings. Furnish setting drawings, templates, and directions for installing anchorages, including sleeves, concrete inserts, anchor bolts, and items with integral anchors, that are to be embedded in concrete or masonry. Deliver such items to Project site in time for installation.
- B. Schedule installation so wall attachments are made only to completed walls. Do not support railings temporarily by any means that do not satisfy structural performance requirements.

PART 2 - PRODUCTS

2.1 MANUFACTURERS: Stainless Steel with Glass Infill

- A. Manufacturers: Subject to compliance with requirements, provide **Basis of Design: Modesto by P&P Artec or equal product by one of the following**. All manufacturers shall match component detailing as delineated on the drawings.
 1. Blum, Julius & Co., Inc.
 2. Livers Bronze Co.

2.2 MATERIALS

- A. Brackets, Flanges, and Anchors: Same metal and finish as supported rails, unless otherwise indicated.
- B. Material quality: Provide materials free from surface blemishes where exposed to view in the finished installation.
- C. Handrails: 304 stainless steel tubing - 1.5" O. D. (1 1/2" diameter) approved by ADA with a 360-400 grit finish.
- D. Balusters: One single baluster post, 304 stainless steel tubing (1-11/16") 1.66" O.D., with a 180 grit polished finish. Top or Side Mounted. See Construction Drawings for mounting type required.
- E. Frame tubes for horizontal infill panels: ard drawn stainless steel tubes - 15mm (5/8" O.D.) with a 360-400 grit finish.
- F. Connection fittings: Stainless Steel in brushed finish.

- G. In-fill Panel (please specify one of the following):
 - 1. horizontal frame tubes.
 - 2. vertical frame tubes, 304 stainless steel - 10mm (3/8" O.D.) with 360-400 grit finish
 - 3. 1/2 clear tempered + laminated where required by code, all four sides polished.
 - 4. tempered glass logo will appear, please check your own local codes.
 - 5. custom design infill (Metal Panels), to be specified
- H. Bolts, Screws & Nuts: 304 Stainless Steel. Do not use metals that will be corrosive and incompatible with materials being fastened.
- I. Mixes: Use Ceramic 6 Epoxy to cast baluster into concrete.

2.3 GLASS AND GLAZING MATERIALS

- A. Tempered Glass: ASTM C 1048, Kind FT (fully tempered), Condition A (uncoated), Type 1 (transparent flat glass), Quality-Q3. Provide products that have been tested for surface and edge compression according to ASTM C 1048 and for impact strength according to 16 CFR 1201 for Category II materials.
 - 1. Tinted Glass: Class 2 (tinted), manufacturer's standard green tint color.
 - 2. Thickness for Glass Infill Panels: As required by structural loads, but not less than 5/16.

2.4 MISCELLANEOUS MATERIALS

- A. Fasteners: Provide concealed fasteners, unless exposed fasteners are unavoidable.
 - 1. Stainless-Steel Components: Type 304 stainless-steel fasteners.
- B. Anchors: Provide cast-in-place or torque-controlled expansion anchors, fabricated from corrosion-resistant materials with capability to sustain, without failure, a load equal to six times the load imposed when installed in unit masonry and equal to four times the load imposed when installed in concrete, as determined by testing per ASTM E 488.
- C. Grout and Anchoring Cement: Factory-packaged, nonshrink, nonmetallic grout complying with ASTM C 1107, or water-resistant, nonshrink, anchoring cement; recommended by manufacturer for exterior use.

2.5 FABRICATION

- A. General: Fabricate railings to comply with design, dimensions, and details indicated, but not less than that required to support structural loads.
- B. Welded Connections: Cope components at connections to provide close fit, or use fittings designed for this purpose. Weld all around at connections, including at fittings.
- C. Mechanical Connections: Connect members with concealed mechanical fasteners and fittings.
- D. Form changes in direction by bending or by inserting prefabricated elbow fittings.

- E. Form curves by bending in jigs to produce uniform curvature; maintain cross section of member throughout bend without cracking or otherwise deforming exposed surfaces.
- F. Close exposed ends of hollow railing members with prefabricated end fittings.
- G. Provide wall returns at ends of wall-mounted handrails, unless otherwise indicated.
- H. Brackets, Flanges, Fittings, and Anchors: Provide wall brackets, flanges, miscellaneous fittings, and anchors to interconnect railing members to other work, unless otherwise indicated.
- I. Examine system components, substrate and condition where railing systems are to be installed. Field measurements must be taken by a manufacturer's technician prior to fabrication.
- J. Review and coordinate setting drawings, templates, and related items that are to be embedded in concrete and masonry.

2.6 FINISHES

- A. Stainless Steel:
 - 1. Directional Satin Finish: No. 4.
- B. Steel:
 - 1. Paint

PART 3 - EXECUTION

3.1 INSTALLATION

- A. General: Perform cutting, drilling, and fitting required for installing railings. Set railings accurately in location, alignment, and elevation.
 - 1. Set posts plumb within a tolerance of 1/16 inch in 3 feet.
 - 2. Align rails so variations from level for horizontal members and variations from parallel with rake of steps and ramps for sloping members do not exceed 1/4 inch in 12 feet.
- B. Anchor posts in concrete by inserting into formed or core-drilled holes and grouting annular space.
- C. Anchor posts to metal surfaces as indicated using fittings designed and engineered for this purpose.
- D. Anchor railing ends to concrete and masonry with flanges connected to railing ends and anchored to wall construction with anchors and bolts.

- E. Attach handrails to wall with wall brackets.
 - 1. For steel-framed partitions, fasten brackets to steel framing or concealed steel reinforcements using self-tapping screws of size and type required to support structural loads.
- F. Top rail will have to terminate in either a wall ending or floor ending to achieve maximum stability.
- G. Wherever possible, achieve equal spacing of balusters.

3.2 Cleaning and protection

- A. Immediately upon completion of installation clean all railing system surface stainless steel cleaner. Do not use abrasive agents or harsh chemicals. Provide plastic sheet protection for all surfaces of completed installations to prevent damage during remainder of construction activities.

END OF SECTION 057300

SECTION 061600 – SHEATHING

PART 1 - GENERAL

1.1 RELATED DOCUMENTS

- A. Drawings and general provisions of the Contract, including General and Supplementary Conditions and Division 1 Specification Sections, apply to this Section.

1.2 SUMMARY

- A. This Section includes the following:
 - 1. Gypsum based sheathing.
 - 2. Sheathing joint-and-penetration treatment.
- B. Related Sections include the following:
 - 1. Division 6 Section “Rough Carpentry” for grounds and nailers.

1.3 INFORMATIONAL SUBMITTALS

- A. Evaluation Reports: For following products, from ICC-ES:
 - 1. Glass mat gypsum wall sheathing.

1.4 SUBMITTALS

- A. Product Data: For each type of process and factory-fabricated product. Indicate component materials and dimensions and include construction and application details.

1.5 DELIVERY, STORAGE, AND HANDLING

- A. Stack plywood and other panels flat with spacers between each bundle to provide air circulation. Provide for air circulation around stacks and under coverings.

PART 2 - PRODUCTS

2.1 WALL SHEATHING

- A. Glass-Mat Gypsum Wall Sheathing: ASTM C 1177/1177M.
 - 1. Product: Subject to compliance with requirements.

- a. "Dens-Glass Gold" by G-P Gypsum Corporation.
 - 2. Type and Thickness: Regular, 1/2 inch.
 - 3. Size: 48 by 96 inches for vertical installation.
- B. Plywood: Either DOC PS 1 or DOC PS 2 unless otherwise indicated.

2.2 FASTENERS

- A. Screws for Fastening Gypsum Sheathing to Cold-Formed Metal Framing: Steel drill screws, in length recommended by sheathing manufacturer for thickness of sheathing board to be attached, with organic-polymer or other corrosion-protective coating having a salt-spray resistance of more than 800 hours according to ASTM B 117.
- 1. For steel framing less than 0.0329 inch thick, attach sheathing to comply with ASTM C 1002.
 - 2. For steel framing from 0.033 to 0.112 inch thick, attach sheathing to comply with ASTM C 954.

2.3 SHEATHING JOINT AND PENETRATION TREATMENT MATERIALS

- A. Joint treatments for Glass-Mat Gypsum Sheathing Board: Comply with requirements of Division 7 Section "Fluid Applied Membrane Air and Vapor Barriers."

2.4 MISCELLANEOUS MATERIALS

- A. Flexible Flashing: Composite, self-adhesive, flashing product consisting of a pliable, rubberized-asphalt compound, bonded to a high-density, cross-laminated polyethylene film to produce an overall thickness of not less than 0.040 inch.
- 1. Confirm adhesion compatibility of all flexible flashings with air and vapor barrier membrane manufacturer.
- B. Primer for Flexible Flashing: Product recommended by manufacturer of flexible flashing for substrate.

PART 3 - EXECUTION

3.1 INSTALLATION, GENERAL

- A. Do not use materials with defects that impair quality of sheathing or pieces that are too small to use with minimum number of joints or optimum joint arrangement.
- B. Cut panels at penetrations, edges, and other obstructions of work; fit tightly against abutting construction, unless otherwise indicated.
- C. Securely attach to substrate by fastening as indicated, complying with the following:

1. Table 2304.9.1, "Fastening Schedule," in ICC's "International Building Code."
- D. Use steel screws coated or uncoated to suit substrate and framing, unless otherwise indicated. Select fasteners of size that will penetrate members to degree recommended by framing manufacturer, but will not penetrate fully through to exposed to view surfaces on the opposite side. Make tight connections. Install fasteners without splitting wood.
- E. Coordinate wall sheathing installation with flashing and joint-sealant installation so these materials are installed in sequence and manner that prevent exterior moisture from passing through completed assembly.
- F. Do not bridge building expansion joints; cut and space edges of panels to match spacing of structural support elements.
- G. Coordinate sheathing installation with installation of materials installed over sheathing so sheathing is not exposed to precipitation or left exposed at end of the workday when rain is forecast.

3.2 GYPSUM SHEATHING INSTALLATION

- A. Comply with GA-253 and with manufacturer's written instructions.
 1. Fasten gypsum sheathing to cold-formed metal framing with screws.
 2. Install boards with a 3/8-inch gap where non-load-bearing construction abuts structural elements.
 3. Install boards with a 1/4-inch gap where they abut masonry or similar materials that might retain moisture, to prevent wicking.
- B. Apply fasteners so heads bear tightly against face of sheathing boards but do not cut into facing.
- C. Vertical Installation: Install board vertical edges centered over studs. Abut ends and edges of each board with those of adjacent boards. Attach boards at perimeter and within field of board to each stud.
 1. Space fasteners approximately 8 inches o.c. and set back a minimum of 3/8 inch from edges and ends of boards.
 2. For sheathing under stucco cladding, boards may be initially tacked in place with screws if overlying self-furring metal lath is screw-attached through sheathing to studs immediately after sheathing is installed.

3.3 SHEATHING JOINT-AND-PENETRATION TREATMENT

- A. Seal sheathing joints according to sheathing manufacturer's written instructions.
 1. Apply glass-fiber sheathing tape to glass-mat gypsum sheathing board joints, and apply and trowel silicone emulsion sealant to embed entire face of tape in sealant. Apply sealant to exposed fasteners with a trowel so fasteners are completely covered. Seal other penetrations and openings.

3.4 FLEXIBLE FLASHING INSTALLATION

- A. Apply flexible flashing where indicated to comply with manufacturers written instructions.
 - 1. Prime substrates as recommended by flashing manufacturer.
 - 2. Lap seams and junctures with other materials at least 4 inches, except that at flashing flanges of other construction, laps need not exceed flange width.
 - 3. After flashing has been applied, roll surfaces with a hard rubber or metal roller to ensure that flashing is completely adhered to substrates.

END OF SECTION 061600

SECTION 064020 - INTERIOR ARCHITECTURAL WOODWORK

PART 1 - GENERAL

1.1 SUMMARY

- A. This Section includes interior woodwork including for the following applications:
 - 1. Plastic-laminate cabinets.
 - 2. Plastic-laminate countertops.
 - 3. Solid-surfacing-material countertops.
 - 4. Shop finishing of woodwork.
- B. Interior architectural woodwork includes wood furring, blocking, shims, and hanging strips, unless concealed within other construction before woodwork installation.

1.2 SUBMITTALS

- A. Product Data: For the following:
 - 1. Cabinet hardware and accessories.
 - 2. Finishing materials and processes.
- B. Shop Drawings:
 - 1. Submit CAD production drawings for casework systems and countertops showing plan view layout of units with relation to surrounding walls, doors, windows, and other building components, elevations, ends, cross-sections, service run spaces and location of services.
 - 2. Coordinate production drawings with other work involved. Casework manufacturer to provide shop drawings for all trades involved in installation of casework.
- C. Samples:
 - 1. Plastic-laminate-clad panel products, for each type, color, pattern, and surface finish.
 - 2. Thermoset decorative-overlay surfaced panel products, for each type, color, pattern, and surface finish.
 - 3. Solid-surfacing materials.
 - 4. Physical working sample of drawer with self-close, soft-close features.
 - 5. Exposed cabinet hardware and accessories, one unit for each type.

1.3 QUALITY ASSURANCE

- A. Installer Qualifications: Manufacturer shall show evidence of a minimum of five years experience in providing manufactured casework systems for similar types of projects, produce

evidence of financial stability, bonding capacity, and adequate facilities and personnel required to perform on this project.

- B. Quality Standard: Unless otherwise indicated, comply with AWI's "Architectural Woodwork Quality Standards" for grades of interior architectural woodwork, construction, finishes, and other requirements.
 - 1. The contractor must provide if requested AWI certification labels or compliance certificate indicating that woodwork complies with requirements of grades specified. Certification labels or compliance certificates must be provided at no cost.
- C. Warranty: All materials and workmanship covered by this section shall carry a three (3) year warranty from date of final acceptance. This warranty is a warranty of replacement and repair only, whereby the manufacturer will correct defects in material and or workmanship without charge.

1.4 PROJECT CONDITIONS

- A. Environmental Limitations: Do not deliver or install woodwork until building is enclosed, wet work is complete, and HVAC system is operating and maintaining temperature and relative humidity at levels planned for building occupants during the remainder of the construction period. Relative humidity range must be stabilized and fall within 20% to 50%. Notify general contractor of humidity requirements prior to delivery.

PART 2 - PRODUCTS

2.1 MATERIALS

- A. Wood Products:
 - 1. Hardboard: AHA A135.4, meet or exceed commercial standard CS-251.
 - 2. Medium-Density Fiberboard: ANSI A208.2, Grade MD.
 - 3. Particleboard: ANSI A208.1, Grade M-3.
- B. Thermoset Decorative Overlay: Particleboard or medium-density fiberboard with surface of thermally fused, melamine-impregnated decorative paper complying with LMA SAT-1.
- C. High-Pressure Decorative Laminate: NEMA LD 3.
 - 1. Manufacturers: Subject to compliance with requirements, provide products by one of the following:
 - a. Formica Corporation.
 - b. Lab Designs.
 - c. Laminart.
 - d. Nevamar.
 - e. Pionite.
 - f. Wilsonart International; Div. of Premark International, Inc.

D. Solid-Surfacing Material: Homogeneous solid sheets of filled plastic resin complying with ANSI Z124.3, for Type 5 or Type 6 material and performance requirements, without a precoated finish.

1. Basis of Design Product: Subject to compliance with requirements, provide Corian Solid Surface by Dupont Ploymers or comparable product by one of the following.
 - a. Avonite, Inc.; Avonite.
 - b. Formica Corporation; Surell.
 - c. Wilsonart International, Div. of Premark International, Inc.; Gibraltar.
2. Basis of Design Color:
 - a. Color at Veterans Center: Evening Prima – Final selection from manufacturer’s full range.
 - b. Color at Reception Desk and Bench: Silverite Prima – Final selection from manufacturer’s full range.
 - c. Color (unless noted otherwise): Arista Mist Prima – Final selection from manufacturer’s full range.

E. Edge Banding:

1. Provide 1 mm PVC banding, machine applied with waterproof hot melt adhesive. This is applicable to all items except for items identified in Note 2 located below.
2. 3mm PVC banding, machine applied waterproof hot melt adhesive with external edges and outside corners of door and drawer fronts, and countertops, machine profiled to 1/8” in radius for safety. Apply at outside corners of bench seating as noted on drawings.
3. PVC banding shall be available in fifty standard colors. All selections color matched to Wilsonart, Nevemar and Formica laminates of the same name.
4. Barbed T-edging or laminate self edge on cabinet components will not be acceptable.

F. Tempered Float Glass for Countertops

1. ASTM C 1048, Kind FT, Conditin A, Type 1, Class 1 (frosted). Quality – Q3; with exposed edges seamed before tempering.
2. Thickness: 6mm thick, unless otherwise indicated.

2.2 CABINET HARDWARE AND ACCESSORIES

- A. General: Provide cabinet hardware and accessory materials for a complete installation of architectural woodwork, except for items specified in Division 8 Section "Door Hardware".
- B. Hardware Standard: Comply with BHMA A156.9 for items indicated by referencing BHMA numbers or items referenced to this standard.
- C. Frameless Concealed Hinges (European Type): BHMA A156.9, B01602, 135 degrees of opening. Doors over 48” shall have three hinges per door.

- D. Bar Pulls: Back mounted, 5” center to center, 1-3/16” projection, 7” overall, 5/16” diameter. Pull design shall be compatible with the Americans with Disability Act including paragraph 4.27.4 of the Federal Register Volume 56, No. 144. Provide solid brass, brushed chrome plated.
- E. Catches: Magnetic, BHMA A156.9, B03141.
- F. Adjustable Shelf Standards and Supports: BHMA A156.9, B04071; with shelf rests, B04081.
1. Supports shall be injection molded polycarbonate, clear color to blend with selected interior finish, friction fit into cabinet end panels and vertical dividers, readily adjustable on 1 1/4” centers. Each shelf support shall have two integral support pins, 5mm diameter, to interface pre-drilled holes, and to prevent accidental rotation of support. The supports shall be automatically adaptable to 3/4” or 1 in. thick shelving and shall provide non-tip feature for shelving. Supports are designed to readily permit field fixing of shelf if desired. Structural load testing shall show loading to 1,040 pounds without failure.
- G. Drawer Slides: Basis of Design: Accuride.
1. Side-mounted, full-extension, zinc-plated steel drawer slides with steel ball bearings, BHMA A156.9, B05091 and rated for the following loads:
 - a. Box Drawer Slides: 100 lbf.
 - b. File Drawer Slides: 200 lbf.
 - c. Pencil Drawer Slides: 45lbf.
 2. Provide positive stop in both directions with self-closing feature.
 3. Provide manufacturer’s standard lifetime warranty.
 4. **Provide soft-close feature.**
- H. Door and Drawer Locks:
1. Basis of Design: National Lock #M4-7054C.
 2. Provide removable core, disc tumbler, cam style lock with strike. Provide two keys for each lock.
 3. Locks in each room shall be keyed alike. Manufacturer shall provide a master key.
- I. Chain bolts:
1. Provide chain bolts 3” long, each shall have a 18” pull and an angle strike to secure inactive door on cabinets over 72” in height. Elbow catches shall be used on inactive doors up to and including 72” in height.
- J. Coat Rods:
1. Coat rods shall be 1 1/4” diameter 14 gauge chrome plated steel installed in captive mounting hardware.
- K. Hanging File Suspension Rails:

1. All file drawers shall include a pair of 14 ga steel hanging file suspension rails, epoxy coated. File followers, or other split bottom hardware shall not be acceptable.
- L. Exposed Hardware Finishes: Complying with BHMA A156.18 for BHMA finish number indicated.
 1. Satin Chromium Plated: BHMA 626 for brass or bronze base; BHMA 652 for steel base.

2.3 INSTALLATION MATERIALS

- A. Furring, Blocking, Shims, and Hanging Strips: Softwood or hardwood lumber, kiln-dried to less than 15 percent moisture content.

2.4 FABRICATION

- A. General: Complete fabrication to maximum extent possible before shipment to Project site. Where necessary for fitting at site, provide allowance for scribing, trimming, and fitting.
 1. Interior Woodwork Grade: Custom complying with the referenced quality standard.
 2. Shop cut openings to maximum extent possible. Sand edges of cutouts to remove splinters and burrs.
 3. Seal edges of openings in countertops with a coat of varnish.
 4. Install glass to comply with applicable requirements in Division 8 Section "Glazing" and in GANA's "Glazing Manual." For glass in wood frames, secure glass with removable stops.
 5. For trim items wider than available lumber, use veneered construction. Do not glue for width.
 6. Backout or groove backs of flat trim members and kerf backs of other wide, flat members, except for members with ends exposed in finished work.
 7. Assemble casings in plant except where limitations of access to place of installation require field assembly.
- B. Plastic-Laminate Cabinets:
 1. AWI Type of Cabinet Construction: Flush overlay.
 - a. Tops and bottoms shall be joined to cabinet ends and internal cabinet components such as fixed horizontals, rails and verticals using 10mm diameter industrial grade hardwood dowels, laterally fluted with chamfered ends, securely glued and clamped under pressure during assembly to secure joints and cabinet squareness. Use minimum of six dowels at each joint for 24" deep cabinets and minimum of four dowels at each joint for 12" deep cabinets.
 - b. All under-counter units except sink base units, shall be provided with full sub-top. Sink base units shall be provided with open top, front welded steel/epoxy painted sink rail full width at top front edge concealed behind face rail/doors split back removable access panels and bottom panel to have CL20 high pressure cabinet liner both faces, color to match interior color.
 - c. All end panels and vertical dividers, except sink base units, shall be prepared to receive adjustable shelf hardware at 32mm (1 1/4") centers. Door hinges, drawer

slides and pull-out shelves shall mount on line boring to maintain vertical alignment of components and provide for future relocation of doors, drawers, shelves and/or pull-out shelves.

- d. 3mm PVC edge banding available in fifty standard colors.
2. WIC Construction Style: Style Face Frame.
 3. WIC Construction Type: Type I, multiple self-supporting units rigidly joined together.
 4. WIC Door and Drawer Front Style: Flush overlay. Door width may not exceed 24”.
 5. Shelving: Provide mid shelf support when length exceeds 30”. Provide 3mm PVC edge banding.
 6. Drawers: The back and sub-front shall be doweled and glued into the sides. Dowels shall be fluted, with chamfered ends and a minimum diameter of 8mm. Top edge is banded with 1mm PVC in a matching color. Dead space in excess of 1” from back of drawer to back of cabinet will not be permitted.
 7. Drawer Bottom: The bottom shall be screwed directly to the front edge of the drawer box.
 8. Laminate Cladding for Exposed Surfaces: High-pressure decorative of grade indicated.
 - a. Horizontal Surfaces Other Than Tops: HGS.
 - b. Postformed Surfaces: HGP.
 - c. Vertical Surfaces VGS.
 - d. Edges: 3mm PVC banding.
 9. Materials for Semiexposed Surfaces Other Than Drawer Bodies: Thermoset decorative overlay.
 - a. Drawer Sides and Backs: Thermoset decorative overlay.
 - b. Drawer Bottoms: Thermoset decorative overlay.
 10. Colors, Patterns, and Finishes: As selected from manufacturer's full range.
- C. Plastic-Laminate Countertops:
1. High-Pressure Decorative Laminate Grade: HGS.
 2. Colors, Patterns, and Finishes: As selected from manufacturer's full range.
 3. Edge Treatment: 3 mm PVC available in a minimum of fifty standard colors.
- D. Solid-Surfacing-Material Countertops:
1. Solid-Surfacing-Material Thickness: 1/2”.
 2. Colors, Patterns, and Finishes: As selected from manufacturer's full range. Price groups 1, 2, & 3. (See Part 2.1 D.2.)
 3. Fabricate tops in one piece with shop-applied backsplashes and edges, unless otherwise indicated. Comply with solid-surfacing-material manufacturer's written recommendations for adhesives, sealers, fabrication, and finishing.

PART 3 - EXECUTION

3.1 INSTALLATION

- A. Inspection: The installer must examine the job site and the conditions under which the work under this section is to be performed, and notify the contractor in writing of unsatisfactory conditions. Do not proceed with work under this section until unsatisfactory conditions have been corrected in a manner acceptable to the installer.
- B. Condition woodwork to average prevailing humidity conditions in installation areas and examine and complete work as required, including removal of packing and back-priming before installation.
- C. Quality Standard: Install woodwork to comply with AWI Section 1700 for the same grade specified in this Section for type of woodwork involved.
- D. Install casework with factory-trained supervision authorized by the manufacturer.
- E. Install woodwork level, plumb, true, and straight to a tolerance of 1/8 inch in 96 inches Shim as required with concealed shims.
- F. Scribe and cut woodwork to fit adjoining work, and refinish cut surfaces and repair damaged finish at cuts.
- G. Anchor woodwork to anchors or blocking built in or directly attached to substrates. Secure with countersunk, concealed fasteners and blind nailing as required for complete installation. Use fine finishing nails or finishing screws for exposed fastening, countersunk and filled flush with woodwork and matching final finish if transparent finish is indicated.
- H. Cabinets: Install without distortion so doors and drawers fit openings properly and are accurately aligned. Adjust hardware to center doors and drawers in openings and to provide unencumbered operation.
 - 1. Fasten wall cabinets through back, near top and bottom, at ends and not more than 16 inches o.c. with No. 10 wafer-head sheet metal screws through metal backing or metal framing behind wall finish.
- I. Countertops: Anchor securely by screwing through corner blocks of base cabinets or other supports into underside of countertop. Caulk space between backsplash and wall with sealant specified in Division 7 Section "Joint Sealants."

END OF SECTION 064020

SECTION 072100 – THERMAL INSULATION

PART 1 - GENERAL

1.1 RELATED DOCUMENTS

- A. Drawings and general provisions of the Contract, including General and Supplementary Conditions and Division 1 Specification Sections, apply to this Section.

1.2 SUMMARY

- A. This Section includes the following:
 - 1. Foam-plastic board insulation.
 - a. Extruded-Polystyrene for masonry wall cavity.
 - 2. Glass-fiber blanket insulation.
 - 3. Spray polyurethane foam insulation.
 - 4. Spray polyurethane foam insulation for penetrations & gaps
 - 5. Insulation accessories.
 - 6. Rigid insulation for assembly: see associated roofing specification.
- B. Related Sections include the following:
 - 1. Division 4 Section "Unit Masonry Assemblies" for insulation installed in cavity walls and masonry cells.
 - 2. Division 7 Section "Fire-Resistive Joint Systems" for insulation installed as part of a perimeter fire-resistive joint system.
 - 3. Division 9 Sections "Gypsum Board" for installation in metal-framed assemblies of insulation specified by referencing this Section.
 - 4. Division 26 for mechanical duct and piping insulation.

1.3 DEFINITIONS

- A. Mineral-Fiber Insulation: Insulation composed of rock-wool fibers, slag-wool fibers, or glass fibers; produced in boards and blanket with latter formed into batts (flat-cut lengths) or rolls.

1.4 SUBMITTALS

- A. Product Data: For each type of product indicated.
- B. Samples for Verification: Full-size units for each type of exposed insulation indicated.
- C. Product Test Reports: Based on evaluation of comprehensive tests performed by a qualified testing agency for insulation products.

1.5 QUALITY ASSURANCE

- A. Source Limitations: Obtain each type of building insulation through one source from a single manufacturer.
- B. Fire-Test-Response Characteristics: Provide insulation and related materials with the fire-test-response characteristics indicated, as determined by testing identical products per test method indicated below by UL or another testing and inspecting agency acceptable to authorities having jurisdiction. Identify materials with appropriate markings of applicable testing and inspecting agency.
 - 1. Surface-Burning Characteristics: ASTM E 84.
 - 2. Fire-Resistance Ratings: ASTM E 119.
 - 3. Combustion Characteristics: ASTM E 136.

1.6 DELIVERY, STORAGE, AND HANDLING

- A. Protect insulation materials from physical damage and from deterioration by moisture, soiling, and other sources. Store inside and in a dry location. Comply with manufacturer's written instructions for handling, storing, and protecting during installation.
- B. Protect plastic insulation as follows:
 - 1. Do not expose to sunlight, except to extent necessary for period of installation and concealment.
 - 2. Protect against ignition at all times. Do not deliver plastic insulating materials to Project site before installation time.
 - 3. Complete installation and concealment of plastic materials as rapidly as possible in each area of construction.

PART 2 - PRODUCTS

2.1 MANUFACTURERS

- A. Available Manufacturers: Subject to compliance with requirements, manufacturers offering products that may be incorporated into the Work include, but are not limited to, manufacturers specified.

2.2 CAVITY-WALL RIGID FOAM BOARD INSULATION

- A. Extruded-Polystyrene Board Insulation: ASTM C 578, Type IV, closed-cell product extruded with an integral skin.
 - 1. Available Manufacturers:
 - a. DiversiFoam Products
 - b. Dow Chemical Company
 - c. Owens Corning
- B. Adhesive: Type recommended by insulation board manufacturer for application indicated.
- C. Insulation Accessories:

1. Tape for sealing joints as recommended by the manufacturer.
- D. Low-expansion foam sealant: Foam sealant for joints and penetrations in board type insulation: One part, low expansion (25% by volume or less) polyurethane insulating foam to use as sealant between rigid insulation panel to panel joints, edges, and thru panel penetrations. 1.5 lb/cu.ft. (18 kg/m³) or greater cured density.
1. Provide foam sealant at board-to-board edges, to seal butt joints between boards, penetrations, and perimeter of insulation at changes in plane or materials.

2.3 GLASS-FIBER BLANKET INSULATION

- A. Available Manufacturers:
1. CertainTeed Corporation.
 2. Johns Manville.
 3. Owens Corning.
- B. Unfaced, Glass-Fiber Blanket Insulation: ASTM C 665, Type I; with maximum flame-spread and smoke-developed indexes of 25 and 50, respectively, per ASTM E 84; passing ASTM E 136 for combustion characteristics.
- C. Provide blankets in batt or roll form with thermal resistances indicated:
1. Wall cavities: R-13 minimum unless otherwise noted
 2. Thicknesses: In single layer and density to achieve specified R-value by itself and located toward the outside (exterior) side of the stud cavity.
 3. Provide additional support to keep insulation in place in accordance with manufacturer's instructions.

2.4 SEMI-RIGID GLASS FIBER INSULATION

- A. Unfaced, Flexible Glass-Fiber Board Insulation: ASTM C 612, Type IA; ASTM C 553, Types I, II, and III; or ASTM C 665, Type I; with maximum flame-spread and smoke-developed indexes of 25 and 50, respectively, per ASTM E 84, passing ASTM E 136 for combustion characteristics.
1. Nominal density of not less than 1.5 lb/cu. ft. nor more than 1.7 lb/cu. ft., thermal resistivity of 4 deg F x h x sq. ft./Btu x in. at 75 deg F.

2.5 SPRAY POLYURETHANE FOAM INSULATION

- A. Closed-Cell Polyurethane Foam Insulation: ASTM C 1029, Type II, with maximum flame-spread and smoke-developed indexes of 75 and 450, respectively, per ASTM E 84.
1. Manufacturers: Subject to compliance with requirements, provide products by one of the following:
 - a. BASF Corporation.
 - b. Dow Chemical Company (The).
 - c. Henry Company.
 2. Minimum density of 1.5 lb/cu. ft., thermal resistivity of 6.2 deg F x h x sq. ft./Btu x in. at 75 deg F.

2.6 INSULATION ACCESSORIES

- A. Vapor-Retarder Tape: Pressure-sensitive tape of type recommended by insulation manufacturers for sealing joints and penetrations in vapor-retarder facings.
- B. Adhesive for Bonding Insulation: Product with demonstrated capability to bond insulation securely to substrates indicated without damaging insulation and substrates. Refer to Division 7 Section “Fluid Applied Air Barriers” for methods used to bond insulation to air / vapor membranes.
- C. Closed Cell Polyurethane Foam for miscellaneous cavity wall insulation as indicated, and penetration and large gap filling applications: Two part, mixed at the applicator, spray applied ASTM E-94 permeance rating of less than 1.0, with total water absorption of less than .03 lbs/cu.ft. (24 hour test). Minimum in place density: no less than 2.4 pcf.
 - 1. “Froth-Pak 180” by Dow Chemical Corporation.
 - 2. “Handi-Foam 205” (2.5 lb/pcf density) by Fomo Products, Inc.
 - 3. “Prozone SCF 2.4” by ProFoam.
 - 4. “Touch n Seal” High Density 3.0 pcf, by Convenience Products.
 - 5. Application includes, but is not limited to concealed locations as follows:
 - a. Tops of walls at roof decking in dry environments to prevent vapor transmission between indoors and exterior wall cavities.
 - b. In-fill gaps around device boxes and conduit routed or scored into rigid roof insulation.
 - c. Fill wall gaps between dissimilar materials or changes in plane, where gaps lead to the cavity space of exterior envelop.
- D. Low-expansion foam sealant: Foam sealant for joints, gaps, and penetrations in board type cavity wall insulation: One part, low expansion (25% by volume or less) polyurethane insulating foam to use as sealant between rigid insulation panel to panel joints, edges, and thru panel penetrations. 1.5 lb/cu.ft. (18 kg/m³) or greater cured density.
 - 1. Application includes, but is not necessarily limited to:
 - a. Miscellaneous non-rated gaps and joints wider than ½ inch and to close gaps between interior and weatherproof enclosure or cavities. Excludes expansion joints with preformed or manufactured metal closure assemblies.
 - b. Gaps ½ inch or less to be sealed in accordance with Division 07 Section “Joint Sealants.”
 - c. Foamed joints to be faced sealed with elastomeric sealants, shall be raked back to correct depth for backer rod and sealant.
- E. Do not use non-rated foam sealants where fire resistive joint materials are to be applied in accordance with Division 7 Section “Firestopping.”

2.7 INSULATION FASTENERS

- A. Exterior insulation is adhesively attached unless otherwise noted or required by the manufacturer. Insulation applied over air barrier systems must obtain written product approval from the air barrier manufacturer certifying that proposed adhesives are compatible with, and will not damage, air barrier systems.

- B. Spindle-Type Anchors (at concrete substrates or where required by the insulation manufacturer for the conditions of application): Plates welded to projecting spindle; capable of holding insulation of thickness indicated securely in position indicated with self-locking washer in place; and complying with the following requirements:
 - 1. Available Products:
 - a. AGM Industries, Inc.; Series T TACTOO Insul-Hangers.
 - b. Eckel Industries of Canada; Stic-Klip Type N Fasteners.
 - c. Gemco; Spindle Type.
 - 2. Plate: Perforated galvanized carbon-steel sheet, 0.030 inch thick by 2 inches square.
 - 3. Spindle: Copper-coated, low carbon steel; fully annealed; 0.105 inch in diameter; length to suit depth of insulation indicated.
 - 4. Where spindle type anchors are used with air barrier systems, spindles shall be in place prior to air barrier application.

- C. Anchor Adhesive: Product with demonstrated capability to bond insulation anchors securely to substrates indicated without damaging insulation, fasteners, and substrates.
 - 1. Available Products, subject to approval of air barrier manufacturer:
 - a. AGM Industries, Inc.; TACTOO Adhesive.
 - b. Eckel Industries of Canada; Stic-Klip Type S Adhesive.
 - c. Gemco; Tuff Bond Hanger Adhesive.

PART 3 - EXECUTION

3.1 EXAMINATION

- A. Examine substrates and conditions, with Installer present, for compliance with requirements of Sections in which substrates and related work are specified and for other conditions affecting performance.
 - 1. Proceed with installation only after unsatisfactory conditions have been corrected.

3.2 PREPARATION

- A. Clean substrates of substances harmful to insulation or vapor retarders, including removing projections capable of puncturing vapor retarders or of interfering with insulation attachment.

3.3 INSTALLATION, GENERAL

- A. Comply with insulation manufacturer's written instructions applicable to products and application indicated.
- B. Install insulation that is undamaged, dry, and unsoiled and that has not been left exposed at any time to ice, rain, and snow.
- C. Extend insulation in thickness indicated to envelop entire area to be insulated. Cut and fit tightly around obstructions and fill voids with insulation. Remove projections that interfere with placement.

- D. For preformed insulating units, provide sizes to fit applications indicated and selected from manufacturer's standard thicknesses, widths, and lengths. Apply single layer of insulation units to produce thickness indicated unless multiple layers are otherwise shown or required to make up total thickness.

3.4 INSTALLATION OF CAVITY-WALL INSULATION

- A. Coordinate installation of Air & Moisture Barrier.
- B. On units of foam-plastic board insulation, install pads of adhesive spaced approximately 24 inches o.c. both ways on inside face, and as recommended by manufacturer. Fit courses of insulation between wall ties and other obstructions, with edges butted tightly and sealed at joints with polyurethane foam, in both directions. Press units firmly against inside substrates indicated.
 - 1. Supplement adhesive attachment of insulation by securing boards with two-piece wall ties designed for this purpose and specified in Division 4 Section "Unit Masonry Assemblies."
 - 2. Fill cracks and open gaps in insulation with low expansion foam sealant compatible with insulation and masonry.

3.5 INSTALLATION OF GENERAL BUILDING INSULATION

- A. Apply insulation units to substrates by method indicated, complying with manufacturer's written instructions. If no specific method is indicated, bond units to substrate with adhesive or use mechanical anchorage to provide permanent placement and support of units.
- B. Foam-Plastic Board Insulation: Seal joints between units by applying adhesive, mastic, or sealant to edges of each unit to form a tight seal as units are shoved into place. Fill voids in completed installation with adhesive, mastic, or sealant as recommended by insulation manufacturer.
- C. Install mineral-fiber insulation in cavities formed by framing members according to the following requirements:
 - 1. Use insulation widths and lengths that fill the cavities formed by framing members. If more than one length is required to fill cavity, provide lengths that will produce a snug fit between ends.
 - 2. Place insulation in cavities formed by framing members to produce a friction fit between edges of insulation and adjoining framing members.
 - 3. For metal-framed wall cavities where cavity heights exceed 96 inches, support faced blankets by taping stapling flanges to flanges of metal studs.
- D. Install board insulation on concrete substrates by adhesively attached, spindle-type insulation anchors as follows:
 - 1. Fasten insulation anchors to concrete substrates with insulation anchor adhesive according to anchor manufacturer's written instructions. Space anchors according to insulation manufacturer's written instructions for insulation type, thickness, and application indicated.
 - 2. After adhesive has dried, install board insulation by pressing insulation into position over spindles and securing it tightly in place with insulation-retaining washers, taking care not to compress insulation below indicated thickness.
 - 3. Where insulation will not be covered by other building materials, apply capped washers to tips of spindles.

- E. Spray-Applied Insulation: Apply spray-applied insulation according to manufacturer's written instructions. Do not apply insulation until installation of pipes, ducts, conduits, wiring, and electrical outlets in walls is completed and windows, electrical boxes, and other items not indicated to receive insulation are masked. After insulation is applied, make flush with face of studs by using method recommended by insulation manufacturer.
- F. Miscellaneous Voids: Install insulation in miscellaneous voids and cavity spaces where required to prevent gaps in insulation using the following materials:
 - 1. Spray Polyurethane Insulation: Apply according to manufacturer's written instructions.
- G. Do not stuff glass fiber insulation into cracks and voids in wall, ceiling, floor or window assemblies unless it serves only to provide uniform depth to the overall insulation plane. Fill voids that occur through the insulation plane with the following materials:
 - 1. Gaps between floors: Refer to Division 07 Section "Firestopping."
 - 2. Gaps open to the exterior or wall cavity behind exterior cladding or veneers: Low expansion spray foam.
 - 3. Gaps between the edges of wall (metal, wood or masonry) framing and dissimilar materials to be concealed and covered: Low density foam.

3.6 PROTECTION

- A. Protect installed insulation from damage due to harmful weather exposures, physical abuse, and other causes. Provide temporary coverings or enclosures where insulation is subject to abuse and cannot be concealed and protected by permanent construction immediately after installation.

END OF SECTION 072100

SECTION 072800 – MEMBRANE AIR BARRIERS AND FLEXIBLE FLASHING

PART 1 - GENERAL

1.1 RELATED DOCUMENTS

- A. Drawings and general provisions of the Contract, including General and Supplementary Conditions and Division 01 Specification Sections, apply to this Section.

1.2 SUMMARY

- A. This Section includes the following non-asphaltic barriers:
 - 1. Fluid-applied membrane air barrier, vapor permeable.
 - 2. Self-adhering flexible sheet membrane flashing.
 - 3. Termination Mastic.
 - 4. Auxiliary materials.
- B. Related Sections include the following:
 - 1. Division 04 Section "Unit Masonry Assemblies" for embedded flashings.
 - 2. Division 07 Section "Joint Sealants" for joint-sealant materials and installation.

1.3 DEFINITIONS

- A. ABAA: Air Barrier Association of America.
- B. Air Barrier Assembly: The collection of air barrier materials and auxiliary materials applied to an opaque wall, including joints and junctions to abutting construction, to control air movement through the wall.

1.4 PERFORMANCE REQUIREMENTS

- A. General: Air barrier shall be capable of performing as a continuous vapor-retarding or vapor permeable air barrier as application warrants, and as a liquid-water drainage plane flashed to discharge to the exterior incidental condensation or water penetration. Air barrier assemblies shall be capable of accommodating substrate movement and of sealing substrate expansion and control joints, construction material changes, and transitions at perimeter conditions without deterioration and air leakage exceeding specified limits.
- B. Air Barrier Assembly Air Leakage: Not to exceed 0.01 cfm x sq. ft. of surface area at 1.57 lbf/sq. ft.; ASTM E 283.

1.5 SUBMITTALS

- A. Product Data: Include manufacturer's written instructions for evaluating, preparing, and treating substrate; technical data; and tested physical and performance properties of air barrier.
- B. Shop Drawings: Show locations and extent of air barrier. Include details for substrate joints and cracks, counterflashing strip, penetrations, inside and outside corners, terminations, and ties with adjoining construction.
 - 1. Include details of interfaces with other materials that form part of air barrier.
- C. Product Certificates: For air barriers, certifying compatibility of air barrier and accessory materials with Project materials that connect to or that come in contact with the barrier; signed by product manufacturer.
- D. Qualification Data: For Applicator.
- E. Product Test Reports: Based on evaluation of comprehensive tests performed by a qualified testing agency, for air barriers.

1.6 QUALITY ASSURANCE

- A. Applicator Qualifications: A firm experienced in applying air barrier materials similar in material, design, and extent to those indicated for this Project, whose work has resulted in applications with a record of successful in-service performance.
- B. Mockups: Before beginning installation of air barrier, assign area of in-place construction to act as a mockup of the exterior wall assembly of approximately 50 sq. ft., incorporating backup wall construction, external cladding, insulation, and flashing to demonstrate surface preparation, crack and joint treatment, and sealing of gaps, terminations, and penetrations of air barrier membrane.
 - 1. Coordinate construction of mockup to permit inspection by Owner's testing agency of air barrier before external insulation and cladding is installed.
 - 2. If Architect determines mockups do not comply with requirements, reconstruct mockups and apply air barrier until mockups are approved.
 - 3. Approved mockups may become part of the completed Work if undisturbed at time of Final Acceptance.
- C. The air barrier shall be joined in an airtight and flexible manner to the air barrier material of adjacent systems, allowing for the relative movement of systems due to thermal and moisture variations and creep. Connection shall be made between:
 - 1) Foundation and walls.
 - 2) Walls and windows or doors.
 - 3) Different wall systems.
 - 4) Wall and roof.
 - 5) Wall and roof over unconditioned space.
 - 6) Walls, floor and roof across construction, control and expansion joints.
 - 7) Walls, floors and roof to utility, pipe and duct penetrations.

- D. Preinstallation Conference: Conduct conference at Project site.
 - 1. Include installers of other construction connecting to air barrier, including roofing, waterproofing, architectural precast concrete, masonry, sealants, windows, glazed curtain walls, and door frames.
 - 2. Review air barrier requirements including surface preparation, substrate condition and pretreatment, minimum substrate curing period, forecasted weather conditions, special details and sheet flashings, mockups, installation procedures, sequence of installation, testing and inspecting procedures, and protection and repairs.

1.7 DELIVERY, STORAGE, AND HANDLING

- A. Store liquid materials in their original undamaged packages in a clean, dry, protected location and within temperature range required by air barrier manufacturer.
- B. Remove and replace liquid materials that cannot be applied within their stated shelf life.
- C. Store rolls according to manufacturer's written instructions.
- D. Protect stored materials from direct sunlight.

1.8 PROJECT CONDITIONS

- A. Environmental Limitations: Apply air barrier within the range of ambient and substrate temperatures recommended by air barrier manufacturer. Protect substrates from environmental conditions that affect performance of air barrier. Do not apply air barrier to a damp or wet substrate or during snow, rain, fog, or mist.

PART 2 - PRODUCTS

2.1 VAPOR-PERMEABLE MEMBRANE AIR BARRIER

- A. General: Air barrier shall be capable of performing as a continuous vapor-permeable air barrier and as a liquid-water drainage plane flashed to discharge to the exterior incidental condensation or water penetration. Air-barrier assemblies shall be capable of accommodating substrate movement and of sealing substrate expansion and control joints, construction material changes, penetrations, and transitions at perimeter conditions without deterioration and air leakage exceeding specified limits.

2.2 FLUID-APPLIED MEMBRANE AIR BARRIER

- A. Fluid-Applied, Vapor-Permeable Membrane Air Barrier: Elastomeric, modified bituminous or Synthetic polymer membrane.
 - 1. Basis of Design: Provide Tremco, Inc., ExoAir 220. Subject to compliance with requirements, provide comparable products by one of the following:

- a. Henry Company; Air-Bloc 06 WB
- b. Grace W. R. & Co.; Perm-A-Barrier VP
- c. Meadows, W. R. Inc.
- d. Carlisle Coatings & Waterproofing, Inc.

2. Physical and Performance Properties:

- a. Membrane Air Permeance: Not to exceed 0.004 cfm/ sq. ft. of surface area at 1.57-lbf/sq. ft. pressure difference; ASTM E 2178.
- b. Vapor permeance: Not to exceed 13 perms; ASTM E 96.

B. Where air barrier membranes are to be exposed to UV degradation for a period of more than 30 days, use manufacturer's UV resistant formulations.

2.3 SELF-ADHERING SHEET MEMBRANE FLASHING

A. Flexible, 40-mil, self-adhering flexible flashing.

- 1. Available Products: Subject to compliance with requirements, products that may be incorporated into the Work include, but are not limited to, the following:
- 2. Products: Subject to compliance with requirements, provide one of the following:
 - a. SBS Modified flexible, self-adhering rubberized asphalt sheet membrane with a polymer film on the surface and a removable treated release film on the adhesive side.
 - 1) Grace Vycor Weather Barrier Strips..
 - 2) Carlisle CCW-705 Window and Door Flashing.
 - 3) Tamko: TW Moisture Wrap.

2.4 AUXILIARY MATERIALS

- A. General: Auxiliary materials recommended by air barrier manufacturer for intended use and compatible with air barrier membrane. Liquid-type auxiliary materials shall comply with VOC limits of authorities having jurisdiction.
- B. Primer: Liquid waterborne primer recommended for substrate by manufacturer of air barrier material.
- C. Counterflashing Strip: Modified bituminous, 40-mil- thick, self-adhering sheet consisting of 32 mils of rubberized asphalt laminated to an 8-mil- thick, crosslaminated polyethylene film with release liner backing.
- D. Modified Bituminous Strip: Vapor-retarding, 40-mil- thick, smooth-surfaced, self-adhering; consisting of 36 mils of rubberized asphalt laminated to a 4-mil- thick polyethylene film with release liner backing.
 - 1. Prime substrate when recommended by manufacturer.
- E. Joint Reinforcing Strip: Air barrier manufacturer's glass-fiber-mesh tape.

- F. Substrate Patching Membrane: Manufacturer's standard trowel-grade substrate filler.
- G. Adhesive and Tape: Air barrier manufacturer's standard adhesive and pressure-sensitive adhesive tape.
- H. Sprayed Polyurethane Foam Sealant: Refer to Division 07 Section "Thermal Insulation". Use primer and noncorrosive substrate cleaner recommended by foam sealant manufacturer.
- I. Modified Bituminous Transition Strip: Vapor-retarding, 40-mil- thick, smooth-surfaced, self-adhering; consisting of 36 mils of rubberized asphalt laminated to a 4-mil- thick polyethylene film with release liner backing.
- J. Elastomeric Flashing Sheet: ASTM D 2000, 2BC415 to 3BC620, minimum 50- to 65-mil-thick, cured sheet neoprene with manufacturer's recommended contact adhesives and lap sealant with stainless-steel termination bars and fasteners.
- K. Preformed Silicone-Sealant Extrusion: Manufacturer's standard system consisting of cured low-modulus silicone extrusion, sized to fit opening widths, with a single-component, neutral-curing, Class 100/50 (low-modulus) silicone sealant for bonding extrusions to substrates.
- L. Joint Sealant: ASTM C 920, single-component, neutral-curing silicone; Class 100/50 (low-modulus), Grade NS, Use NT related to exposure, and, as applicable to joint substrates indicated, Use O. Comply with Division 07 Section "Joint Sealants."
- M. **Termination Mastic:** Air barrier manufacturer's termination mastic.
 - 1. Basis of design: ExoAir Termination mastic.

PART 3 - EXECUTION

3.1 EXAMINATION

- A. Examine substrates, areas, and conditions, with Installer present, for compliance with requirements and other conditions affecting performance.
 - 1. Verify that substrates are sound and free of oil, grease, dirt, excess mortar, or other contaminants.
 - 2. Verify that masonry joints are flush and completely filled with mortar.
 - 3. Proceed with installation only after unsatisfactory conditions have been corrected.

3.2 SURFACE PREPARATION

- A. Clean, prepare, treat, and seal substrate according to manufacturer's written instructions. Provide clean, dust-free, and dry substrate for air barrier application.
- B. Mask off adjoining surfaces not covered by air barrier to prevent spillage and overspray affecting other construction.

- C. Remove grease, oil, bitumen, form-release agents, paints, curing compounds, and other penetrating contaminants or film-forming coatings from concrete.
- D. Remove fins, ridges, mortar, and other projections and fill honeycomb, aggregate pockets, holes, and other voids with substrate patching membrane.
- E. Remove excess mortar from masonry ties, shelf angles, and other obstructions.
- F. At changes in substrate plane, apply sealant or termination mastic beads at sharp corners and edges to form a smooth transition from one plane to another.
- G. Cover gaps in substrate plane and form a smooth transition from one substrate plane to another with stainless-steel sheet mechanically fastened to structural framing to provide continuous support for air barrier.

3.3 JOINT TREATMENT

- A. Concrete and Masonry: Prepare, treat, rout, and fill joints and cracks in substrate according to ASTM C 1193 and air barrier manufacturer's written instructions. Remove dust and dirt from joints and cracks complying with ASTM D 4258 before coating surfaces.
 - 1. Prime substrate and apply a single thickness of preparation coat strip extending a minimum of 3 inches along each side of joints and cracks. Apply a double thickness of air barrier membrane and embed a joint reinforcing strip in preparation coat.
- B. Gypsum Sheathing: Fill joints greater than 1/4 inch with sealant according to ASTM C 1193 and with air barrier manufacturer's written instructions. Apply first layer of fluid air barrier membrane at joints. Tape joints with joint reinforcing strip after first layer is dry. Apply a second layer of fluid air barrier membrane over joint reinforcing strip.

3.4 TRANSITION STRIP INSTALLATION

- A. Install strips, transition strips, and auxiliary materials according to air barrier manufacturer's written instructions to form a seal with adjacent construction and maintain a continuous air barrier.
 - 1. Coordinate the installation of air barrier with installation of roofing membrane and base flashing to ensure continuity of air barrier with roofing membrane.
 - 2. Install modified bituminous strip on roofing membrane or base flashing so that a minimum of 3 inches of coverage is achieved over both substrates.
 - 3. Ensure that all wood blocking intended to support window frame systems is fully in place prior to placing base flashings at openings.
- B. Apply primer to substrates at required rate and allow to dry. Limit priming to areas that will be covered by air barrier sheet in same day. Re-prime areas exposed for more than 24 hours.
 - 1. Prime glass-fiber-surfaced gypsum sheathing with number of prime coats needed to achieve required bond, with adequate drying time between coats.

- C. Connect and seal exterior wall air barrier membrane continuously to roofing membrane air barrier, concrete below-grade structures, floor-to floor construction, exterior glazing and window systems, glazed curtain-wall systems, storefront systems, exterior louvers, exterior door framing, and other construction used in exterior wall openings, using accessory materials.
- D. At end of each working day, seal top edge of strips and transition strips to substrate with termination mastic.
- E. Apply joint sealants forming part of air barrier assembly within manufacturer's recommended application temperature ranges. Consult manufacturer when sealant cannot be applied within these temperature ranges.
- F. Wall Openings: Prime concealed perimeter frame surfaces of windows, curtain walls, storefronts, and doors. Apply modified bituminous transition strip so that a minimum of 3 inches of coverage is achieved over both substrates. Maintain 3 inches of full contact over firm bearing to perimeter frames with not less than 1 inch of full contact.
 - 1. Modified Bituminous Transition Strip: Roll firmly to enhance adhesion.
 - 2. Elastomeric Flashing Sheet: Apply adhesive to wall, frame, and flashing sheet. Install flashing sheet and termination bars, fastened at 6 inches o.c. Apply lap sealant over exposed edges and on cavity side of flashing sheet.
- G. Fill gaps in perimeter frame surfaces of windows, curtain walls, storefronts, and doors, and miscellaneous penetrations of air barrier membrane with foam sealant.
- H. Seal strips and transition strips around masonry reinforcing or ties and penetrations with termination mastic.
- I. Seal top of through-wall flashings to air barrier with an additional 6-inch- wide, modified bituminous strip.
- J. Seal exposed edges of strips at seams, cuts, penetrations, and terminations not concealed by metal counterflashings or ending in reglets with termination mastic.
- K. Repair punctures, voids, and deficient lapped seams in strips and transition strips. Slit and flatten fishmouths and blisters. Patch with transition strips extending 6 inches beyond repaired areas in strip direction.

3.5 AIR BARRIER MEMBRANE INSTALLATION

- A. Apply air barrier membrane to form a seal with strips and transition strips and to achieve a continuous air barrier according to air barrier manufacturer's written instructions.
- B. Apply air barrier membrane within manufacturer's recommended application temperature ranges.
- C. Apply primer to substrates at required rate and allow to dry. Limit priming to areas that will be covered by air barrier sheet in same day. Re-prime areas exposed for more than 24 hours.

1. Prime glass-fiber-surfaced gypsum sheathing with number of prime coats needed to achieve required bond, with adequate drying time between coats.
- D. Apply a continuous unbroken air barrier to substrates according to the following minimum thickness. Apply membrane in full contact around protrusions such as masonry ties.
1. Vapor-Permeable Membrane Air Barrier: 90-120 mils wet, no less than 47 mils dry thickness.
- E. Apply strip and transition strip a minimum of 1 inch onto cured air membrane or strip and transition strip over cured air membrane overlapping 3 inches onto each surface according to air barrier manufacturer's written instructions.
- F. Do not cover air barrier until it has been tested and inspected by Owner's testing agency.
- G. Correct deficiencies in or remove air barrier that does not comply with requirements; repair substrates and reapply air barrier components.

3.6 FIELD QUALITY CONTROL

- A. Testing Agency: Owner will engage a qualified testing agency to perform tests and inspections and prepare test reports.
- B. Inspections: Air barrier materials and installation are subject to inspection for compliance with requirements. Inspections may include the following:
1. Continuity of air barrier system has been achieved throughout the building envelope with no gaps or holes.
 2. Continuous structural support of air barrier system has been provided.
 3. Masonry and concrete surfaces are smooth, clean and free of cavities, protrusions, and mortar droppings.
 4. Site conditions for application temperature and dryness of substrates have been maintained.
 5. Maximum exposure time of materials to UV deterioration has not been exceeded.
 6. Surfaces have been primed, if applicable.
 7. Laps in strips and transition strips have complied with minimum requirements and have been shingled in the correct direction (or mastic has been applied on exposed edges), with no fishmouths.
 8. Termination mastic has been applied on cut edges.
 9. Strips and transition strips have been firmly adhered to substrate.
 10. Compatible materials have been used.
 11. Transitions at changes in direction and structural support at gaps have been provided.
 12. Connections between assemblies (membrane and sealants) have complied with requirements for cleanliness, preparation and priming of surfaces, structural support, integrity, and continuity of seal.
 13. All penetrations have been sealed.
- C. Tests: Testing to be performed will be determined by Owner's testing agency from among the following tests:

1. Qualitative Testing: Air barrier assemblies will be tested for evidence of air leakage according to ASTM E 1186, chamber pressurization or depressurization with smoke tracers.
 2. Quantitative Air Leakage Testing: Testing not to exceed the test pressure differential, positive and negative, indicated in "Performance Requirements" Article for air barrier assembly air leakage according to ASTM E 283.
- D. Remove and replace deficient air barrier components and retest as specified above.

3.7 CLEANING AND PROTECTION

- A. Protect air barrier system from damage during application and remainder of construction period, according to manufacturer's written instructions.
1. Protect air barrier from exposure to UV light and harmful weather exposure as required by manufacturer. Remove and replace air barrier exposed for more than 30 days unless UV resistant formulations were used.
 2. Protect air barrier from contact with creosote, uncured coal-tar products, TPO, EPDM, flexible PVC membranes, and sealants not approved by air barrier manufacturer.
- B. Clean spills, stains, and soiling from construction that would be exposed in the completed work using cleaning agents and procedures recommended by manufacturer of affected construction.
- C. Remove masking materials after installation.

END OF SECTION 072726

SECTION 074213 - METAL COMPOSITE MATERIAL WALL PANELS

PART 1 - GENERAL

1.1 SUMMARY

- A. Section includes metal composite material wall panels.
 - 1. Soffits and Fascia.
 - 2. Exterior walls.
 - 3. ACM Panel System Dry Seal Type.

1.2 PREINSTALLATION MEETINGS

- A. Preinstallation Conference: Conduct conference at Project site.

1.3 ACTION SUBMITTALS

- A. Product Data: For each type of product.
- B. Shop Drawings: Include fabrication and installation layouts of metal composite material panels; details of edge conditions, joints, panel profiles, corners, anchorages, attachment assembly, trim, flashings, closures, and accessories; and special details.

All shop drawings shall be sealed by an engineer registered in North Carolina. Shop drawings shall include all design loads (both positive and negative), all calculations, complete layout, all details, connections, anchors, reinforcing, stiffeners, sealants and all other accessories and parts in their entirety as necessary for all complete, first-class job.

- C. Samples: For each type and color of metal composite material panel indicated.
- D. Mock-Up: Prior to proceeding with the installation build a mock-up panel for approval showing all connections, reinforcements, attachments, stud framing, sheathing, membranes, flashings and sealants. If approved, the mock-up panel may be incorporated in the final work.

1.4 INFORMATIONAL SUBMITTALS

- A. Product test reports.
- B. Warranties: Samples of special warranties.

1.5 CLOSEOUT SUBMITTALS

- A. Maintenance data.

1.6 QUALITY ASSURANCE

- A. Installer Qualifications: An entity that employs installers and supervisors who are trained and approved by manufacturer.

1.7 WARRANTY

- A. Special Warranty: Manufacturer's standard form in which manufacturer agrees to repair or replace components of metal composite material panel systems that fail in materials or workmanship within specified warranty period.

- 1. Warranty Period: Three years from date of Final Acceptance.

- B. Special Warranty on Panel Finishes: Manufacturer's standard form in which manufacturer agrees to repair finish or replace metal composite material panels that show evidence of deterioration of factory-applied finishes within specified warranty period.

- 1. Finish Warranty Period: 20 years from date of Final Acceptance.

PART 2 - PRODUCTS

2.1 PERFORMANCE REQUIREMENTS

- A. Structural Performance: Provide metal composite material panel systems capable of withstanding the effects of the following loads, based on testing according to ASTM E 330:

- 1. Wind Loads: Maximum design pressures that meet or exceed ASCE 7-10.

- a. Reference structural drawing S1.01 for component and cladding design pressure requirements.

- b. Provide calculations from the manufacturer supporting the system as designed meets the specified loading per ASCE 7-10 as indicated on drawing **S1.01**. If manufacturer cannot provide calculations, provide structural analysis calculations signed and sealed by a qualified structural engineer registered in the state of North Carolina. Analysis shall include sealed ASCE 7-10 calculations.

- 2. Deflection Limits: For wind loads, no greater than 1/240 of the span.

- B. Air Infiltration: Air leakage of not more than 0.06 cfm/sq. ft. when tested according to ASTM E 283 at the following test-pressure difference:

- 1. Test-Pressure Difference: 6.24 lbf/sq. ft.

- C. Water Penetration under Static Pressure: No water penetration when tested according to ASTM E 331 at the following test-pressure difference:

- 1. Test-Pressure Difference: 6.24 lbf/sq. ft.

- D. Thermal Movements: Allow for thermal movements from ambient and surface temperature changes by preventing buckling, opening of joints, overstressing of components, failure of joint

sealants, failure of connections, and other detrimental effects. Base calculations on surface temperatures of materials due to both solar heat gain and nighttime-sky heat loss.

1. Temperature Change (Range): 120 deg F , ambient; 180 deg F , material surfaces.
- E. Fire-Resistance Ratings: Comply with ASTM E 119; testing by a qualified testing agency. Identify products with appropriate markings of applicable testing agency.
1. Indicate design designations from UL's "Fire Resistance Directory" or from the listings of another qualified testing agency.
- F. Fire Propagation Characteristics: Metal composite material wall panel system passes NFPA 285 testing.

2.2 METAL COMPOSITE MATERIAL WALL PANELS

- A. Metal Composite Material Wall Panel Systems: Provide factory-formed and -assembled, metal composite material wall panels fabricated from two metal facings that are bonded to a solid, extruded thermoplastic core; formed into profile for installation method indicated. Include attachment assemblies components, panel stiffeners, and accessories required for weathertight system.
1. Basis-of-Design Product: Subject to compliance with requirements, provide metal panel system “Alpolic” by Mitsubishi Chemical Group. or comparable product by one of the following:
 - a. “Alucobond ACM” by 3A Composites USA, Inc.
 - b. Reynobond by Arconic Architectural Products.
- B. Aluminum-Faced Composite Wall Panels: Two sheets formed with 0.020-inch- thick, aluminum sheet facings sandwiching a core of extruded thermoplastic material formed in a continuous process with no glue or adhesives between dissimilar materials. Products laminated sheet by sheet or in a batch process using glues or adhesives between materials shall not be acceptable.
1. Panel Thickness: 0.157 inch (4.0 mm) (Typical)
 - a. Increase thickness as necessary to provide panel sizes as called for on drawings.
 2. Panel Weight: 4mm (0.157”): 1.12 lbs/sq. ft.
 3. Core: Standard.
 4. Exterior Finish: Two-coat fluoropolymer min. Provide coating with 70% Kynar 500/Hylar 5000 polyvinylidene fluoride (PVDF) resins with Fluoropolymer technology – coil coated.
 - a. Finish system shall meet or exceed specified warranty.
 - b. Color: **Custom color to match existing panels on buildings. Existing campus panels are: CMX Metallic Champagne Stock (color). Provided panels must be able to match existing panels to remain on building.** Color selected by Architect from full range including premium custom metallic colors. Coating shall consist of a 0.2 mil prime coat, a 0.75 finish coat containing 70% Kynar Resins with a 0.5 mil clear coat containing 70 % resins.

- C. System Type: **Dry Seal System.**
 - 1. System must provide a perimeter aluminum extrusion with integral weather-stripping.
 - 2. No field sealant required in joints unless specifically noted on drawings.
- D. Attachment Assembly Components: Formed from extruded aluminum.
- E. Attachment Assembly: Manufacturer's standard.

2.3 MISCELLANEOUS MATERIALS

- A. Miscellaneous Metal Subframing and Furring: ASTM C 645, cold-formed, metallic-coated steel sheet ASTM A 653/A 653M, G90 coating designation or ASTM A 792/A 792M, Class AZ50 aluminum-zinc-alloy coating designation unless otherwise indicated. Provide manufacturer's standard sections as required for support and alignment of metal composite material panel system.
- B. Panel Accessories: Provide components required for a complete, weathertight panel system including trim, copings, fasciae, mullions, sills, corner units, clips, flashings, sealants, gaskets, fillers, closure strips, and similar items. Match material and finish of metal composite material panels unless otherwise indicated.
- C. Flashing and Trim: Provide flashing and trim formed from same material as metal composite material panels as required to seal against weather and to provide finished appearance. Locations include, but are not limited to, bases, drips, sills, jambs, corners, endwalls, framed openings, rakes, fasciae, parapet caps, soffits, reveals, and fillers. Finish flashing and trim with same finish system as adjacent metal composite material panels.
- D. Panel Fasteners: Self-tapping screws designed to withstand design loads. Provide exposed fasteners with heads matching color of metal composite material panels by means of plastic caps or factory-applied coating. Provide EPDM or PVC sealing washers for exposed fasteners.
- E. Panel Sealants: ASTM C 920; as recommended in writing by metal composite material panel manufacturer. Provide sealant types recommended by manufacturer that are compatible with panel materials, are nonstaining, and do not damage panel finish.

2.4 FABRICATION

- A. General: Fabricate and finish metal composite material panels and accessories at the factory, by manufacturer's standard procedures and processes, as necessary to fulfill indicated performance requirements demonstrated by laboratory testing. Comply with indicated profiles and with dimensional and structural requirements.
 - 1. Provide single panel for canopy roofs. Roof panel shall be custom formed as shown on drawings. Provide additional panel framing and substrate as necessary to insure that the roof surfaces remain flat and without oil-canning.
 - 2. Provide 40 mil peel-n-stick membrane on substrate under roof panel. Provide proper drainage path to exterior of panel system from underside of roof panel.

- B. Fabricate metal composite material panel joints with factory-installed captive gaskets or separator strips that provide a weathertight seal and prevent metal-to-metal contact, and that minimize noise from movements.
- C. Sheet Metal Flashing and Trim: Fabricate flashing and trim to comply with manufacturer's recommendations and recommendations in SMACNA's "Architectural Sheet Metal Manual" that apply to design, dimensions, metal, and other characteristics of item indicated.

2.5 FINISHES

- A. Panels and Accessories:
 - 1. Two-Coat Fluoropolymer: AAMA 620. Fluoropolymer finish containing not less than 70 percent PVDF resin by weight in color coat. Prepare, pretreat, and apply coating to exposed metal surfaces to comply with coating and resin manufacturers' written instructions.

PART 3 - EXECUTION

3.1 PREPARATION

- A. Miscellaneous Supports: Install subframing, furring, and other miscellaneous panel support members and anchorages according to ASTM C 754 and metal composite material panel manufacturer's written recommendations.

3.2 METAL COMPOSITE MATERIAL PANEL INSTALLATION

- A. Attachment Assembly, General: Install attachment assembly required to support metal composite material wall panels and to provide a complete weathertight wall system, including subgirts, perimeter extrusions, tracks, drainage channels, panel clips, and anchor channels.
 - 1. Include attachment to supports, panel-to-panel joinery, panel-to-dissimilar-material joinery, and panel-system joint seals.
- B. Installation: Attach metal composite material wall panels to supports at locations, spacings, and with fasteners recommended by manufacturer to achieve performance requirements specified.
 - 1. Dry Seal Systems: Seal horizontal and vertical joints between adjacent metal composite material wall panels with manufacturer's standard gasket system.
- C. Accessory Installation: Install accessories with positive anchorage to building and weathertight mounting and provide for thermal expansion. Coordinate installation with flashings and other components.
- D. Flashing and Trim: Comply with performance requirements, manufacturer's written installation instructions, and SMACNA's "Architectural Sheet Metal Manual." Provide concealed fasteners where possible and set units true to line and level as indicated. Install work with laps, joints, and seams that are permanently watertight.

3.3 CLEANING

- A. Remove temporary protective coverings and strippable films, if any, as metal composite material panels are installed, unless otherwise indicated in manufacturer's written installation instructions. On completion of metal composite material panel installation, clean finished surfaces as recommended by metal composite material panel manufacturer. Maintain in a clean condition during construction.

END OF SECTION 074213

SECTION 075400 - THERMOPLASTIC SINGLE-PLY ROOFING

PART 1 GENERAL

1.01 WORK INCLUDED

- A. Install a mechanically attached, thermoplastic membrane, rigid insulation and flashings to provide a permanently watertight system.

1.02 RELATED DOCUMENTS

- A. Drawings and general provisions of the Contract, including General and Supplementary Conditions and Specification Sections, apply to this Section, including but not limited to:
 - 1. Sheet Metal Flashing and Trim - Section 076200.

1.03 REFERENCES

- A. Refer to the following references, current edition for specification compliance:
 - 1. NC State Building Code.
 - 2. ASTM International.
 - 3. National Roofing Contractors Association (NRCA).
 - 4. Underwriters Laboratory (UL).
 - 5. FM Global.
 - 6. Single Ply Roofing Institute.

1.04 SUBMITTALS

- A. Refer to Section 013300 - Submittal Procedures for Submittals.
- B. Latest edition of the Manufacturer's current material specifications and installation instructions.
- C. Manufacturer's Product Data Sheets for all materials specified certifying material complies with all specified requirements.
- D. Submit documentation of approved, tested roof system to meet the specified requirements for the following:
 - 1. Wind Loads: Reference sheet S1.01 for structural loading requirements. Roof shall meet, ASCE 7-10.
 - 2. UL Fire Resistance Rating.
 - 3. Shop drawing of roof plan showing fastening requirements for each roof sector and each roof zone.
 - a. Include structural analysis data signed and sealed by a qualified structural engineer registered in the state of North Carolina responsible for their preparation. Analysis shall include sealed ASCE 7-10 calculations.

1.05 DELIVERY, STORAGE AND HANDLING

- A. All products delivered to the job site shall be in the original unopened containers or wrappings bearing all seals and approvals.
- B. Handle all materials to prevent damage. Place all materials on pallets and fully protect from moisture.
- C. Membrane rolls shall be stored lying down on pallets and fully protected from the weather with clean canvas tarpaulins. Unvented polyethylene tarpaulins are not accepted due to the accumulation of moisture beneath the tarpaulin in certain weather conditions that may affect the ease of membrane weldability.
- D. All adhesives shall be stored at temperatures approved for the product.
- E. All flammable materials shall be stored in a cool, dry area away from sparks and open flames. Follow precautions outlined on containers or supplied by material manufacturer/supplier.
- F. All materials which are determined to be damaged by the Engineer or membrane manufacturer are to be removed from the job site and replaced at no cost to the Owner.

1.06 PROJECT CONDITIONS

- A. Roofing shall not be applied during precipitation. Contractor assumes all responsibility for starting installation in the event there is a probability of precipitation occurring during application.
- B. Only as much of the new roofing as can be made weathertight each day, including all flashing and detail work, shall be installed. All seams shall be cleaned and heat welded before leaving the job site that day.
- C. All work shall be scheduled and executed without exposing the interior building areas to the effects of inclement weather. The existing building and its contents shall be protected against all risks.
- D. All surfaces to receive new insulation, membrane or flashings shall be dry. Should surface moisture occur, the Applicator shall provide the necessary equipment to dry the surface prior to application.
- E. All new and temporary construction, including equipment and accessories, shall be secured in such a manner as to preclude wind blow-off and subsequent roof or equipment damage.
- F. Uninterrupted waterstops shall be installed at the end of each day's work and shall be completely removed before proceeding with the next day's work. Waterstops shall not emit dangerous or unsafe fumes and shall not remain in contact with the finished roof as the installation progresses. Contaminated membrane shall be replaced at no cost to the Owner.
- G. Arrange work sequence to avoid use of newly constructed roofing as a walking surface or for equipment movement and storage. Where such access is absolutely required, the Applicator shall provide all necessary protection and barriers to segregate the work area and to prevent damage to adjacent areas. A protection layer of plywood over insulation board shall be provided for all new and existing roof areas that receive rooftop traffic during construction.

- H. Prior to and during application, all dirt, debris and dust shall be removed from surfaces, either by vacuuming, sweeping, blowing with compressed air and/or similar methods.
- I. Contaminants, such as grease, fats, oils, and solvents, shall not be allowed to come into contact with the roofing membrane. All rooftop contamination that is anticipated or that is occurring shall be reported to the Engineer and membrane manufacturer to determine the corrective steps to be taken.
- J. If any unusual or concealed condition is discovered, the contractor shall stop work, notify Owner of such condition immediately, and in writing within 24 hours.
- K. The roofing membrane shall not be installed under the following conditions without consulting the membrane manufacturer's technical department for precautionary steps:
 - 1. The roof assembly permits interior air to pressurize the membrane underside.
 - 2. Any exterior wall has 10% or more of the surface area comprised of opening doors or windows.
 - 3. The wall/deck intersection permits air entry into the wall flashing area.
- L. Precautions shall be taken when using membrane adhesives at or near rooftop vents or air intakes. Adhesive odors could enter the building. Coordinate the operation of vents and air intakes in such a manner as to avoid the intake of adhesive odor while ventilating the building. Keep lids on unused cans at all times.

1.07 QUALITY ASSURANCE

- A. Manufacturer Requirements:
 - 1. Manufacturer must have written contractor/installer approval program.
 - 2. Products manufactured by other manufacturers and private labeled are not acceptable.
 - 3. See materials section for general product description and specified requirements.
- B. Contractor Requirements:
 - 1. This roofing system shall be applied only by a Contractor authorized by the membrane manufacturer prior to bid.
 - 2. Application of the roofing system shall be accomplished by a primary roofing contractor, his roofing foreman, and sufficient applicator technicians who all have been trained and approved by the manufacturer of the single ply roofing system. Contractor to submit evidence of qualification from the manufacturer.
- C. Upon completion of the installation an inspection shall be made by a representative of the membrane manufacturer to review the installed roof system and list all deficiencies.
- D. There shall be no deviation made from the Contract Documents or the approved shop drawings without prior written approval by the Engineer.
- E. All work shall be completed by personnel trained and authorized by the membrane manufacturer.
- F. Contractor to provide manufacturer written verification indicating all seams have been

probed and are watertight.

G. Install roofing system to meet UL 790 Class A Fire Rating.

H. Wind Design:

1. Install roofing system to meet or exceed the requirements of ASCE-7 (Version 10), and shall be an approved assembly tested to the wind uplift pressures listed below:
 - a. Wind Loads: Reference sheet S1.01 for structural loading requirements. Roof shall meet Section 6, ASCE 7-10.

1.08 WARRANTIES

- A. Manufacturer's Guarantee: Manufacturer's standard form, non-pro-rated, without monetary limitation or deductibles, in which manufacturer agrees to repair or replace components of roofing system that fail in materials or workmanship within specified warranty period. Failure includes roof leaks or breaches in the primary roof membrane causing moisture to enter the substrate below (even if visible leaks are not observed inside the facility). Warranty to remain in effect for wind speeds up to 73 mph. Warranties requiring the Owner's signature will not be acceptable.
1. Warranty to include but not be limited to membrane, insulation, adhesives, fasteners, sealants, flashings, polymer clad sheet metal, etc.
 2. Warranty Period: Twenty years from date of Final Acceptance.
 3. Manufacturer's Representative shall attend two post construction field inspections: the first no earlier than twenty-three (23) months and no later than twenty-four (24) months after the date of Final Acceptance and the second no earlier than fifty-nine (59) months and no later than sixty (60) months. Submit a written report within seven (7) days of the site visits to the Engineer listing observations, conditions and any recommended repairs or remedial action.

PART 2 PRODUCTS

2.01 MANUFACTURER

A. Membrane materials shall be manufactured by the following:

1. Basis of Design: Carlisle Syntec, "White".
2. Sika Sarnafil.
3. Fibertite.

2.02 MEMBRANE MATERIALS

1. Membrane Adhesive: Shall be membrane manufacturer's solvent or water based reactivating-type adhesive. Water based adhesive shall not be utilized in temperatures below 40 degrees F.
- B. Mechanically Attached Membrane and Components:

1. Membrane.
 - a. Basis of Design: Carlisle Sure-Flex PVC 60 mil Membrane.
 - b. Sika Sarnafil, 60 mil, S327.
 - c. Fibertite 45 mil SM.
2. Coverstrip: Shall be 8” wide pre-cut polyester reinforced flashing strip.
3. Membrane Fasteners and Plates/Attachment Bar: Shall be approved and provided by membrane manufacturer for the deck type and membrane configuration.
 - a. Fastener shall be phillips head, carbon steel fastener with corrosion resistant coating designed for use with specified plate meeting the following minimum requirements:
 - i. Shank diameter: .21”.
 - ii. Thread diameter: .26”.
 - iii. Head diameter: .435”.
 - iv. Thread density: 13 turns per inch.
 - b. Plate shall be 18 gauge, 1-1/2 inch by 2-3/4 inch high strength, linear steel plate with an AZ 55 galvalume coating.
 - c. Attachment Bar: Shall be “U”-shaped, roll formed 14 gauge galvanized steel bar with holes punched 1” on center and be manufactured and supplied by the membrane Manufacturer.

2.03 ROOF INSULATION

- A. Polyisocyanurate Board Insulation: ASTM C 1289, type II, felt or glass-fiber mat facer on both major surfaces. Average thickness of rigid roof insulation shall be at least 3 inches (refer to drawings).
- B. Tapered Insulation: Provide factory-tapered insulation boards fabricated to slope of 1/4 inch per 12 inches unless otherwise indicated.
- C. Provide preformed saddles, crickets, tapered edge strips, and other insulation shapes where indicated for sloping to drain. Fabricate to slopes indicated.

2.04 INSULATION ACCESSORIES

- A. Fasteners: Factory-coated steel fasteners and metal or plastic plates meeting corrosion-resistance provisions in FMG 4470, designed for fastening roof insulation to substrate, and acceptable to roofing system manufacturer.

2.05 RELATED MATERIALS

- A. Flashing/Stripping Membrane: Shall be a non fleeceback, thermoplastic membrane reinforced with fiberglass. Utilize asphalt resistant flashing membrane where in contact with residual asphaltic materials or as required by the manufacturer.
 1. Basis of Design: Carlisle Sure-Flex 60 mil Membrane.
 2. Sika Sarnafil 60 mil G410.
 3. Fibertite 45 mil SM.
- B. Flashing Adhesive: Shall be membrane manufacturer’s solvent based reactivating-type adhesive.

- C. T-joint Patch: Shall be membrane manufacturer's circular patch welded over T-joints formed by overlapping thick membranes.
- D. Corner Flashing: Shall be membrane manufacturer's pre-formed inside and outside flashing corners that are heat-welded to membrane or polymer clad metal base flashings.
- E. Pipe Flashing: Shall be membrane manufacturer's pre-formed pipe boot flashing that is heat-welded to membrane and secured with a stainless steel draw band and sealant.
- F. Termination Bar: Shall be manufacturer's 1/8" by 1" mill finish extruded aluminum bar with pre-punched slotted holes.
- G. Counterflashing Bar: Shall be a prefabricated extruded aluminum metal counterflashing and termination bar. 0.10"-0.12" thick bar with 2-1/4" profile, pre-drilled holes 8" on center and sealant kick out at top edge.
- H. Sealant: Shall be manufacturer's multi-purpose sealant.
- I. Fasteners:
 - 1. Flashing Membrane Termination Screws: #12 stainless steel hex or pan head screws with length to penetrate substrate a minimum of 1-1/2".
 - 2. Concrete and Masonry Flashing Membrane Termination Anchors:
 - a. 1/4" diameter metal based expansion anchor with stainless steel pin of length to penetrate substrate a minimum of 1-1/2".
 - b. Masonry screws, approved by membrane manufacturer, 1/4 inch minimum diameter, corrosion resistant, with Phillips flat head. Length to provide minimum 1-1/2" embedment into substrate.
 - 3. Steel Deck Fasteners and Plates: Shall be #12 hot dipped galvanized steel pan head screw approved by membrane manufacturer of length to penetrate top flange of steel deck a minimum of 1" with galvalume plates approved for membrane attachment.
 - 4. Cementitious Wood Fiber Deck Fasteners and Plates: Shall be specially designed fiberglass filled nylon fastener with 1" diameter head approved by membrane manufacturer for cementitious wood fiber applications, corrosion resistant and of length to penetrate deck a minimum of 1-1/2" and at least 1/2" from penetrating through wood fiber with 2" round plate approved for membrane attachment.
- J. Primary Membrane Cleaner: Shall be a high quality solvent cleaner provided by membrane manufacturer and approved by engineer for use as a general membrane cleaner.
- K. Pre-weld Cleaner: Shall be a high quality solvent based seam cleaner with moderate evaporation rate provided by membrane manufacturer.
- L. Walkway Pad: Shall be walkway pad by manufacturer of membrane.
- M. Retrofit Roof Drain: Shall be a prefabricated aluminum drain insert composed of 11 gauge spun aluminum drain body, PVC coated 17.5" diameter flange, cast aluminum clamping ring, cast aluminum strainer, watertight U-Flow seal and stem length and diameter as required by field conditions. Drain shall be approved by roof system manufacturer.

Contractor shall field verify drain diameter and required stem length prior to ordering drains.

- N. Pre-Fabricated Expansion Joint: Shall be manufacturer's approved pre-fabricated expansion joint made with polyester reinforced membrane, neoprene foam and galvanized metal.
- O. Polymer Clad Metal: Refer to Section 076200 - Sheet Metal Flashing and Trim.

PART 3 EXECUTION

3.01 SUBSTRATE PREPARATION

- A. Verify that the substrate is dry, clean, smooth, and free of loose material, oil, grease, or other foreign matter. Sharp ridges and other projections and accumulations of bitumen shall be removed to ensure a smooth surface before roofing.
- B. Asphalt roofing substrates shall be removed, covered, or flashed using compatible, approved materials. PVC shall not come in contact with substrates containing asphalt materials.
- C. Any deteriorated substrate shall be repaired.
- D. Beginning installation means acceptance of prepared substrate.
- E. Provide necessary protection from adhesive vapors to prevent interaction with foamed plastic insulation.

3.02 INSULATION INSTALLATION

- A. Coordinate installing membrane roofing system components so insulation is not exposed to precipitation or left exposed at the end of the workday.
- B. Comply with membrane roofing system manufacturer's written instructions for installing roof insulation.
- C. Install tapered insulation under area of roofing to conform to slopes indicated.
- D. Install one or more layers of insulation under area of roofing to achieve required thickness. Where overall insulation thickness is 2 inches or greater, install 2 or more layers with joints of each succeeding layer staggered from joints of previous layer a minimum of 6 inches in each direction.
- E. Mechanically Fastened and Adhered Insulation: Install each layer of insulation and secure first layer of insulation to deck using mechanical fasteners specifically designed and sized for fastening specified board-type roof insulation to deck type.
 - 1. Fasten first layer of insulation to resist uplift pressure at corners, perimeter, and field of roof.
 - 2. Install subsequent layers of insulation in a solid mopping of hot roofing asphalt, applied within plus or minus 25 deg F of equiviscous temperature.
 - 3. Install subsequent layers of insulation in a cold fluid-applied adhesive.

3.03 MEMBRANE INSTALLATION

- A. General:

1. Membrane is to be attached with membrane fasteners and plates according to membrane manufacturer's requirements.
2. Membrane overlaps shall be shingled with the flow of water.
3. Full-width rolls of membrane shall be fastened perpendicular to the direction of the steel deck flutes.
4. Tack welding of membrane rolls for purposes of temporary restraint during installation is not permitted.

B. Perimeter and Corner Areas:

1. Over the properly installed and prepared substrate surface, half-width rolls (60" width) are to be installed either parallel or perpendicular to the entire perimeter edge. Membrane fasteners and plates are installed along the edge of the membrane on the fastening line six (6") inches on center. Plate is held back 1 inch from the outer edge of the membrane. The adjacent half-roll is positioned to overlap the fastened edge of the first half-roll by 5-1/2 inches in accordance with the overlap lines marked on the sheet's edge. The 5-1/2 inch overlap will allow the top membrane to extend 2-1/2 inches past the membrane fastener and plate for heat-welding. Fasteners shall clamp the membrane tightly to the substrate. In corner areas where perimeter half-rolls intersect, add rows spaced 54-1/2" on center of membrane fasteners and plates over the top of the half-rolls and weld a coverstrip above them for watertightness.
2. Refer to the Contract Drawings for perimeter and corner layout.
3. Hot-air weld overlaps according to membrane manufacturer's requirements. Seam test cuts shall be taken at least 3 times per day.

C. Field Area:

1. Over the properly installed and prepared substrate surface, full-width rolls (120") are to be installed perpendicular to the steel deck flutes. Membrane fasteners and plates are installed along the edge of the membrane on the fastening line six (6") inches on center. Plates are held-back 1 inch from the outer edge of the membrane. The adjacent full-roll is positioned to overlap the fastened edge of the first full-roll by 5-1/2 inches in accordance with the overlap lines marked on the sheet's edge. The 5-1/2 inch overlap will allow the top membrane to extend 2-1/2 inches past the membrane fastener and plate for heat-welding. Fasteners shall clamp the membrane tightly to the substrate.
2. Hot-air weld overlaps according to membrane manufacturer's recommendations. Seam test cuts shall be taken at least 3 times per day.

3.04 MEMBRANE TERMINATION

A. Terminate membrane at all walls as shown in the contract drawings.

1. Roof Deck: Membrane shall be mechanically terminated using approved fasteners and plates six (6) inches on center.
2. Wood Wall Substrate: Membrane shall be turned up wall one inch and mechanically terminated using approved screws eight (8) inches on center with a termination bar.
3. Concrete/Masonry Wall Substrate: Membrane shall be turned up wall one inch and mechanically terminated using approved anchors eight (8) inches on center

with a termination bar.

- B. Terminate membrane at all penetrations as shown in the contract drawings.
 - 1. Membrane shall be fastened six inches on center or a minimum of four (4) fasteners per penetration into the structural deck using fasteners and plates as approved by the membrane manufacturer for the deck substrate.
- C. Membrane shall extend over roof edge a minimum of 2” below the perimeter wood blocking.

3.05 FLASHING INSTALLATION

- A. General:
 - 1. All flashings shall be installed concurrently with the roof membrane as the job progresses.
 - 2. No temporary flashings shall be allowed without the prior written approval of the Engineer and Manufacturer. Approval shall only be for specific locations on specific dates. If any water is allowed to enter under the newly completed roofing, the affected area shall be removed and replaced at the Contractor's expense.
 - 3. Seams shall not be “taped” as temporary measure but shall be fully completed before the end of each day.
 - 4. Flashing shall be adhered to compatible, dry, smooth, and solvent-resistant surfaces.
 - 5. Where substrates are incompatible with adhesives and PVC materials, the Contractor shall remove the incompatible materials and replace it with a compatible substrate, or install compatible PVC flashing materials.
 - 6. Use caution to ensure adhesive fumes are not drawn into the building.
- B. Adhesive for Flashing Membrane:
 - 1. Over the properly installed and prepared flashing substrate, flashing adhesive shall be applied according to instructions found on the Product Data Sheet. The membrane adhesive shall be applied in smooth, even coats with no gaps, globs or similar inconsistencies.
 - 2. Only an area which can be completely covered in the same day's operations shall be flashed. The bonded sheet shall be pressed firmly in place with a hand roller.
 - 3. No adhesive shall be applied in seam areas that are to be welded.
- C. All flashings shall mechanically terminated a minimum of 8 inches above the finished roofing surface using approved fasteners and counterflashing bar unless otherwise indicated in the Contract Drawings. Flashing heights less than 8” shall be accepted in writing by the Manufacturer’s Technical Department.
- D. All flashing membranes shall be consistently adhered to substrates. All interior and exterior corners and miters shall be cut and hot-air welded into place. No bitumen shall be in contact with the (roof) membrane.
- E. All flashings shall be hot-air welded at their joints and at their connections with the (roof) membrane.

- F. All flashings that exceed 30 inches (0.75 m) in height shall receive additional securement. Consult Manufacturer's Technical Department for securement methods.
- G. Corners shall be flashed using the membrane manufacturer's pre-formed corners.
- H. Polymer Clad sheet metal incorporated into the roofing system shall be sealed off with a heat welded stripping ply. The stripping ply shall extend four inches beyond sheet metal onto roof membrane and fit closely to edge of sheet metal.
- I. Roof Drain:
1. Mechanically attach membrane 6" on center into structural deck around drain sump. Fully adhere flashing membrane and hot-air weld to membrane a minimum of 4 inches.
 2. Flashing membrane shall be set in a full bed of sealant under the clamping ring.
 3. Provide new cast iron strainer dome and clamping ring and provide new stainless steel clamping ring bolts.
 4. Clamping rings shall be secured in place with all bolts at the end of each work day. Contractor shall water test roof drains after every instance the clamping ring is removed and reinstalled. The Contractor shall notify the Engineer and Owner of the water test schedule.
- J. Retrofit Roof Drain:
1. Mechanically attach membrane 6" on center into structural deck around drain sump. Fully adhere flashing membrane and hot-air weld to membrane a minimum of 2 inches.
 2. Flashing membrane shall be set in a full bed of sealant under the clamping ring.
 3. Install retrofit roof drain according to manufacturer's installation instructions and provide stripping membrane hot-air welded to flange of retrofit roof drain extending onto flashing membrane.
 4. Clamping rings shall be secured in place with all bolts at the end of each work day. Contractor shall water test roof drains after every instance the clamping ring is removed and reinstalled. The Contractor shall notify the Owner of the water test schedule.
- K. Soil Pipe/Pipe Penetration:
1. Provide field wrapped pipe penetration flashing or manufacturer's pre-fabricated pipe boot as shown in detail drawing.
 2. Apply aluminum tape to penetration if asphalt contamination is present.
 3. Extend existing pipe to obtain a minimum 8" finished flashing height.
 4. Cut existing pipe to obtain a maximum 12" finished flashing height.
 5. Horizontal flashing membrane shall be hot-air welded a minimum of four inches onto the membrane.
 6. Vertical flashing membrane shall be fully adhered to pipe penetration and extend a minimum of 1.5" horizontal at the base of penetration. Hot-air weld vertical flashing membrane to horizontal flashing membrane.
 7. Install stainless steel draw band and sealant or hot-air weld flashing cap to terminate top edge of pipe flashing.

3.06 HOT-AIR WELDING OF SEAM OVERLAPS

- A. General:
1. All seams shall be hot-air welded. Seam overlaps should be 3 inches (75 mm) wide when automatic machine-welding and 4 inches (100 mm) wide when hand-welding, except for certain details.
 2. Welding equipment shall be provided by or approved by the membrane manufacturer. All mechanics intending to use the equipment shall have successfully completed a training course provided by a membrane manufacturer's technical representative prior to welding.
 3. All membrane to be welded shall be clean and dry.
- B. Hand-Welding:
1. Hand-welded seams shall be completed in two stages. Hot-air welding equipment shall be allowed to warm up for at least one minute prior to welding.
 2. The back edge of the seam shall be welded with a narrow but continuous weld to prevent loss of hot air during the final welding.
 3. The nozzle shall be inserted into the seam at a 45 degree angle to the edge of the membrane. Once the proper welding temperature has been reached and the membrane begins to "flow," the hand roller is positioned perpendicular to the nozzle and pressed lightly. For straight seams, the 1½ inch (40 mm) wide nozzle is recommended for use. For corners and compound connections, the ¾ inch (20 mm) wide nozzle shall be used.
- C. Machine Welding:
1. Machine welded seams are achieved by the use of automatic welding equipment. When using this equipment, instructions from the manufacturer shall be followed and local codes for electric supply, grounding and over current protection observed. Dedicated circuit house power or a dedicated portable generator is recommended. No other equipment shall be operated off the generator.
 2. Metal tracks may be used over the deck membrane and under the machine welder to minimize or eliminate wrinkles.
- D. Quality Control of Welded Seams:
1. The Applicator shall check all welded seams for continuity using a rounded screwdriver. Visible evidence that welding is proceeding correctly is smoke during the welding operation, shiny membrane surfaces, and an uninterrupted flow of dark grey material from the underside of the top membrane. On-site evaluation of welded seams shall be made daily by the Applicator to locations as directed by the Engineer or membrane manufacturer's representative. One-inch (25 mm) wide cross-section samples of welded seams shall be taken at least three times a day. Correct welds display failure from shearing of the membrane prior to separation of the weld. Each test cut shall be patched by the Applicator at no extra cost to the Owner.

3.07 WALKWAY PAD INSTALLATION

- A. Roofing membrane to receive walkway pad shall be clean and dry.

- B. Place chalk lines on sheet to indicate location of Walkway.
- C. Apply a continuous coat of membrane adhesive to the sheet and the back of walkway pad in accordance with membrane manufacturer's technical requirements and press walkway pad into place with a water-filled, foam-covered lawn roller.
- D. Clean the membrane in areas to be welded. Hot-air weld the entire perimeter of the walkway to the roofing membrane.
- E. Check all welds with a rounded screwdriver. Re-weld any inconsistencies.
- F. Important: Check all existing membrane seams that are to be covered by walkway with rounded screwdriver and re-weld any inconsistencies before walkway installation.

3.08 TEMPORARY CUT-OFF

- A. All flashings shall be installed concurrently, with the membrane in order to maintain a watertight condition as the work progresses.
- B. When a break in the day's work occurs in the central area of the project install a temporary watertight seal. An 8" strip of flashing membrane shall be welded 4" to the new field membrane. The remaining 4" of flashing membrane shall be sealed to the deck and/or the substrate so that water will not be allowed to travel under the new or existing membrane. The edge of the membrane shall be sealed in a continuous heavy application of pourable sealer of 6-inch width. When work resumes, the contaminated membrane shall be removed and disposed of. None of these materials shall be reused in the new work.
- C. If inclement weather occurs while a temporary water stop is in place, the Contractor shall provide the labor necessary to monitor the situation to maintain a watertight condition.
- D. If any water is allowed to enter under the newly-completed system, the affected area shall be removed and replaced at the Contractor's expense.

3.09 CLEANING AND PROTECTION

- A. The Contractor shall be responsible for protecting the roof from construction related damages during the Work.
- B. The Contractor shall ensure trash and debris is removed from the roof daily.
- C. Metal scraps, nails, screws and other sharp damaging debris shall be kept off of the roof membrane surface during construction.
- D. The Contractor shall clean off/remove excess adhesive, sealant, stains and residue on the membrane and flashing surfaces.
- E. The Contractor shall repair or remove and replace damaged membrane, flashings and other membrane components. Repairs shall be approved by the Engineer and be in accordance with the membrane manufacturers repair instruction to comply with the specified warranty.
- F. The Contractor shall remove temporary coverings and masking protection from adjacent work areas upon completion.

END OF SECTION 075400

SECTION 076200 - SHEET METAL FLASHING AND TRIM

PART 1 - GENERAL

1.1 SUMMARY

A. This Section includes the following:

1. Gutters.
2. Downspouts.
3. Splash pans.
4. Metal step flashings.
5. Formed wall flashing and trim.

B. Related Sections:

1. Division 7 Sections "Thermoplastic Single Ply Roofing" and "Roof Accessories" for flashings associated with these assemblies.

1.2 SUBMITTALS

A. Product Data: For each product indicated.

B. Shop Drawings: Show layouts, profiles, shapes, seams, dimensions, and details for fastening, joining, supporting, and anchoring sheet metal flashing and trim.

C. Samples: For each type of sheet metal flashing and trim.

1.3 QUALITY ASSURANCE

A. Sheet Metal Flashing and Trim Standard: Comply with SMACNA's "Architectural Sheet Metal Manual". Conform to dimensions and profiles shown unless more stringent requirements are indicated.

B. Shop Drawings: Show layout, profiles, methods of joining, and anchorage details. Include major components such as gutters, downspouts, and conductor (collector) boxes.

C. Samples: 8 square inches of each color and finish of sheet materials to be exposed as finished surfaces.

D. Preinstallation Conference: Conduct conference at Project site.

PART 2 - PRODUCTS

2.1 MANUFACTURERS

- A. In other Part 2 articles where titles below introduce lists, the following requirements apply to product selection:
 - 1. Available Manufacturers: Manufacturer shall be by metal roof manufacturer.

2.2 SHEET METALS

- A. Pre-painted, Metallic-Coated Steel Sheet (non-roof edge, concealed from public view): Steel sheet metallic coated by the hot-dip process and pre-painted by the coil-coating process to comply with ASTM A 755/A 755M.
 - 1. Zinc-Coated (Galvanized) Steel Sheet: ASTM A 653/A 653M, G90 coating designation; structural quality.
 - a. For flashings: No less than 22 gauge exposed, 24 gauge fully concealed.
 - b. For Roof drainage components: As specified.
 - 2. Exposed Finishes: Apply the following coil coating:
 - a. Factory Prime Coating: Factory-applied, baked-on epoxy primer coat.
 - b. High-Performance Organic Finish: Two-coat thermocured system containing not less than 70 percent polyvinylidene fluoride resin by weight; complying with physical properties and coating performance requirements of AAMA 2604, except as modified for below:
 - 1) Similar to Valspar “Fluoropon” or PPG “Duranar” finish.
 - 2) Color: As selected by Architect from manufacturer’s full range.
 - 3. Prefinished sheet metal construction includes:
 - a. Gutters.
 - b. Downspouts.
 - c. Metal counter flashings.

2.3 MISCELLANEOUS MATERIALS

- A. General: Provide materials and types of fasteners, solder, welding rods, protective coatings, separators, sealants, and other miscellaneous items as required for complete sheet metal flashing and trim installation.
- B. Felt Underlayment: ASTM D 226, Type II (No. 30), asphalt-saturated organic felt, non-perforated.
 - 1. Slip Sheet: Rosin-sized paper, minimum 3 lb/100 sq. ft.

- C. Fasteners: Same metal as flashing/sheet metal or other non-corrosive metal as recommended by the sheet manufacturer. Match finish of exposed heads with material being fastened.
- D. Sealing Tape: Pressure-sensitive, 100 percent solids, polyisobutylene compound sealing tape with release-paper backing. Provide permanently elastic, nonsag, nontoxic, non-staining tape.
- E. Elastomeric Sealant: ASTM C 920, elastomeric polyurethane polymer sealant; of type, grade, class, and use classifications required to seal joints in sheet metal flashing and trim and remain watertight.
- F. Mastic Sealant: ASTM C 1311, single-component, solvent-release butyl rubber sealant, polyisobutylene plasticized, heavy bodied for hooked-type expansion joints with limited movement.
- G. Bituminous Coating: Cold-applied asphalt mastic, SSPC-Paint 12, compounded for 15-mil dry film thickness per coat.

2.4 FABRICATION, GENERAL

- A. General: Custom fabricate sheet metal flashing and trim to comply with recommendations in SMACNA's "Architectural Sheet Metal Manual" that apply to design, dimensions, metal, and other characteristics of item indicated. Shop fabricate items where practicable. Obtain field measurements for accurate fit before shop fabrication.
- B. Fabricate sheet metal flashing and trim without excessive oil canning, buckling, and tool marks and true to line and levels indicated, with exposed edges folded back to form hems.
 - 1. Seams: Fabricate nonmoving seams in accessories with flat-lock seams. Tin edges to be seamed, form seams, and solder.
- C. Sealed Joints: Form nonexpansion but movable joints in metal to accommodate elastomeric sealant to comply with SMACNA recommendations.
- D. Expansion Provisions: Where lapped or bayonet-type expansion provisions in the Work cannot be used, form expansion joints of intermeshing hooked flanges, not less than 1 inch deep, filled with butyl sealant concealed within joints.
- E. Conceal fasteners and expansion provisions where possible on exposed-to-view sheet metal flashing and trim, unless otherwise indicated.
- F. Fabricate cleats and attachment devices from same material as accessory being anchored or from compatible, noncorrosive metal, and in thickness not less than that of metal being secured.

2.5 ROOF DRAINAGE SHEET METAL FABRICATIONS

- A. Hanging Gutters: Fabricate to cross section indicated, complete with end pieces, outlet tubes, and other accessories as required. Fabricate in minimum 96-inch- long sections. Furnish flat-stock gutter spacers and gutter brackets fabricated from same metal as gutters, of size recommended by SMACNA but not less than twice the gutter thickness. Fabricate expansion

joints, expansion-joint covers, gutter bead reinforcing bars, and gutter accessories from same metal as gutters.

1. Gutter supports shall be fascia mounted gutter brackets
2. Accessories: Wire ball downspout strainer.
3. Fabricate from the following material and gage:

Girth	Coated Steel	Copper
Up to 15"	26 gage	16 oz.
16" to 20"	24 gage	16 oz.
21" to 25"	22 gage	16 oz.
26" to 30"	20 gage	20 oz.
31" to 35"	18 gage	24 oz.
Over 35"	16 gage	24 oz.

4. Downspouts: Fabricate rectangular downspouts complete with mitered elbows. Furnish with metal hangers, from same material as downspouts, and anchors.
5. Fabricate downspouts from the following material:
 - a. Pre-painted, Metallic-Coated Steel: 22 gauge or .032 inch aluminum.

2.6 LOW SLOPE SHEET METAL FABRICATIONS

- A. Base Flashing: Fabricate from the following material:
 1. Pre-painted, Metallic-Coated Steel: 24 gauge.
- B. Counterflashing and Flashing Receivers: Fabricate from the following material:
 1. Pre-painted, Metallic-Coated Steel: 24 gauge.
- C. Roof-Penetration Flashing: Fabricate from the following material:
 1. Zinc-Tin Alloy-Coated Stainless Steel: 0.015 inch thick.
- D. Roof-Drain Flashing: Fabricate from the following material:
 1. Zinc-Tin Alloy-Coated Stainless Steel: 0.015 inch thick.
- E. Splash Pans: Fabricate from the following materials:
 1. Stainless Steel; 0.019 inch thick.
- F. Apron, Step, Cricket, and Backer Flashing: Fabricate from the following material:
 1. Pre-painted, Metallic-Coated Steel: 24 gauge.
- G. Eave, Rake Flashing: Fabricate from the following material:
 1. Pre-painted, Metallic-Coated Steel: 22 gauge .

2.7 WALL SHEET METAL FABRICATIONS

- A. Openings Flashing in Frame Construction: Fabricate head, sill, jamb, and similar flashings to extend 4 inches beyond wall openings. Form head and sill flashing with 2-inch-high end dams. Fabricate from the following material:
 - 1. Pre-painted, Metallic-Coated Steel: 22 gauge.

PART 3 - EXECUTION

3.1 INSTALLATION, GENERAL

- A. General: Anchor sheet metal flashing and trim and other components of the Work securely in place, with provisions for thermal and structural movement. Use fasteners, solder, welding rods, protective coatings, separators, sealants, and other miscellaneous items as required to complete sheet metal flashing and trim system.
 - 1. Torch cutting of sheet metal flashing and trim is not permitted.
- B. Metal Protection: Where dissimilar metals will contact each other or corrosive substrates, protect against galvanic action by painting contact surfaces with bituminous coating or by other permanent separation as recommended by fabricator or manufacturers of dissimilar metals.
- C. Install exposed sheet metal flashing and trim, without excessive oil canning, buckling, and tool marks.
- D. Install sheet metal flashing and trim true to line and levels indicated. Provide uniform, neat seams with minimum exposure of solder, welds, and elastomeric sealant.
- E. Install sheet metal flashing and trim to fit substrates and to result in watertight performance. Verify shapes and dimensions of surfaces to be covered before fabricating sheet metal.
 - 1. Space cleats not more than 12 inches apart. Anchor each cleat with two fasteners. Bend tabs over fasteners.
- F. Expansion Provisions: Provide for thermal expansion of exposed flashing and trim. Space movement joints at a maximum of 10 feet with no joints allowed within 24 inches of corner or intersection. Where lapped or bayonet-type expansion provisions cannot be used or would not be sufficiently watertight, form expansion joints of intermeshing hooked flanges, not less than 1 inch deep, filled with elastomeric sealant concealed within joints.
- G. Fasteners: Use fasteners of sizes that will penetrate substrate not less than 1-1/4 inches for nails and not less than 3/4 inch for wood screws.
 - 1. Galvanized or Pre-painted, Metallic-Coated Steel: Use stainless-steel fasteners.
 - 2. Stainless Steel: Use stainless-steel fasteners.
- H. Seal joints with elastomeric sealant as required for watertight construction.

- I. Soldered Joints: Clean surfaces to be soldered, removing oils and foreign matter. Pre-tem edges of sheets to be soldered to a width of 1-1/2 inches except where pre-tinned surface would show in finished Work.
 - 1. Do not solder pre-painted, metallic-coated steel sheet.
- J. Fabricate conductor heads and splash pans with all soldered lap seam construction. Fold lap seam all exposed edges. Do not use pop rivets or other exposed fasteners.

3.2 ROOF DRAINAGE SYSTEM INSTALLATION

- A. General: Install sheet metal roof drainage items to produce complete roof drainage system according to SMACNA recommendations and as indicated. Coordinate installation of roof perimeter flashing with installation of roof drainage system.
- B. Hanging Gutters: Join sections with riveted and soldered joints or with lapped joints sealed with elastomeric sealant. Provide for thermal expansion. Attach gutters at eave or fascia to firmly anchored gutter brackets spaced not more than 36 inches apart. Provide end closures and seal watertight with sealant. Slope to downspouts.
 - 1. Install gutter with expansion joints at locations indicated but not exceeding 50 feet apart. Install expansion joint caps.
- C. Downspouts: Join sections with 1-1/2-inch telescoping joints. Provide fasteners designed to hold downspouts securely 1 inch away from walls; locate fasteners at top and bottom and at approximately 60 inches o.c. in between.
- D. Conductor Heads: Anchor securely to wall with elevation of conductor head rim 1 inch below gutter discharge.

3.3 ROOF FLASHING INSTALLATION

- A. General: Install sheet metal roof flashing and trim to comply with performance requirements and SMACNA's "Architectural Sheet Metal Manual." Provide concealed fasteners where possible, set units true to line, and level as indicated. Install work with laps, joints, and seams that will be permanently watertight.
- B. Counterflashing: Coordinate installation of counterflashing with installation of base flashing. Insert counterflashing in receivers and fit tightly to base flashing. Secure in a waterproof manner. Extend counterflashing 4 inches over base flashing. Lap counterflashing joints a minimum of 4 inches and bed with elastomeric sealant.
- C. Roof-Penetration Flashing: Coordinate installation of roof-penetration flashing with installation of roofing and other items penetrating roof. Install flashing as follows:
 - 1. Turn lead flashing down inside vent piping, being careful not to block vent piping with flashing.
 - 2. Seal with elastomeric sealant and clamp flashing to pipes penetrating roof except for lead flashing on vent piping.

- D. Refer to Division 7 Section “Roof Specialties” for roof edge and ridge flashing assemblies.

3.4 WALL FLASHING INSTALLATION

- A. General: Install sheet metal wall flashing to intercept and exclude penetrating moisture according to SMACNA recommendations and as indicated. Coordinate installation of wall flashing with installation of wall-opening components such as windows, doors, and louvers.
- B. Openings Flashing in Frame Construction: Install continuous head, sill, jamb, and similar flashings to extend 4 inches beyond wall openings.

END OF SECTION 076200

SECTION 079200 - JOINT SEALANTS

PART 1 - GENERAL

1.1 SUMMARY

- A. This Section includes joint sealants for the following applications, including those specified by reference to this Section:
 - 1. Exterior joints in vertical surfaces and horizontal nontraffic surfaces.
 - 2. Interior joints in vertical surfaces and horizontal nontraffic surfaces.
- B. See Division 8 Section "Glazing" for glazing sealants.

1.2 PERFORMANCE REQUIREMENTS

- A. Provide joint sealants that establish and maintain watertight and airtight continuous joint seals without staining or deteriorating joint substrates.

1.3 SUBMITTALS

- A. Product Data: For each joint-sealant product indicated.
- B. Sealant schedule listing each sealant used for each type of material. Provide manufacturers recommendations regarding prepriming for each material. Provide manufacturers certification that each sealant is approved for use on each proposed application. .

1.4 QUALITY ASSURANCE

- A. Preconstruction Field-Adhesion Testing: Before installing elastomeric sealants, field test their adhesion to Project joint substrates according to the method in ASTM C 1193 that is appropriate for the types of Project joints.

1.5 WARRANTY

- A. Special Installer's Warranty: Installer's standard form in which Installer agrees to repair or replace elastomeric joint sealants that do not comply with performance and other requirements specified in this Section within specified warranty period.
 - 1. Warranty Period: Two years from date of Final Acceptance.
- B. Special Manufacturer's Warranty: Manufacturer's standard form in which elastomeric sealant manufacturer agrees to furnish elastomeric joint sealants to repair or replace those that do not comply with performance and other requirements specified in this Section within specified warranty period.

1. Warranty Period: 10 years from date of Final Acceptance.

PART 2 - PRODUCTS

2.1 MANUFACTURERS

- A. Products: Subject to compliance with requirements, provide one of the products listed in other Part 2 articles.

2.2 MATERIALS, GENERAL

- A. Compatibility: Provide joint sealants, backings, and other related materials that are compatible with one another and with joint substrates under conditions of service and application, as demonstrated by sealant manufacturer, based on testing and field experience.
- B. Colors of Exposed Joint Sealants: As selected by Architect from manufacturer's full range.

2.3 JOINT-SEALANT BACKING

- A. General: Provide sealant backings of material and type that are nonstaining; are compatible with joint substrates, sealants, primers, and other joint fillers; and are approved for applications indicated by sealant manufacturer based on field experience and laboratory testing.
- B. Elastomeric Tubing Sealant Backings: Neoprene, butyl, EPDM, or silicone tubing complying with ASTM D 1056, nonabsorbent to water and gas, and capable of remaining resilient at temperatures down to minus 26 deg F. Provide products with low compression set and of size and shape to provide a secondary seal, to control sealant depth, and to otherwise contribute to optimum sealant performance.
- C. Bond-Breaker Tape: Polyethylene tape or other plastic tape recommended by sealant manufacturer for preventing sealant from adhering to rigid, inflexible joint-filler materials or joint surfaces at back of joint where such adhesion would result in sealant failure. Provide self-adhesive tape where applicable.

2.4 MISCELLANEOUS MATERIALS

- A. Primer: Material recommended by joint-sealant manufacturer where required for adhesion of sealant to joint substrates indicated, as determined from preconstruction joint-sealant-substrate tests and field tests.
- B. Cleaners for Nonporous Surfaces: Chemical cleaners acceptable to manufacturers of sealants and sealant backing materials, free of oily residues or other substances capable of staining or harming joint substrates and adjacent nonporous surfaces in any way, and formulated to promote optimum adhesion of sealants to joint substrates.
- C. Masking Tape: Nonstaining, nonabsorbent material compatible with joint sealants and surfaces adjacent to joints.

PART 3 - EXECUTION

3.1 PREPARATION

- A. Surface Cleaning of Joints: Clean out joints immediately before installing joint sealants.
 - 1. Remove all foreign material from joint substrates that could interfere with adhesion of joint sealant.
 - a. Clean porous joint substrate surfaces by brushing, grinding, blast cleaning, mechanical abrading, or a combination of these methods to produce a clean, sound substrate capable of developing optimum bond with joint sealants. Remove loose particles remaining after cleaning operations above by vacuuming or blowing out joints with oil-free compressed air.
 - 2. Remove laitance and form-release agents from concrete.
 - a. Clean nonporous surfaces with chemical cleaners or other means that do not stain, harm substrates, or leave residues capable of interfering with adhesion of joint sealants.
- B. Joint Priming: Prime joint substrates, where recommended in writing by joint-sealant manufacturer, based on preconstruction joint-sealant-substrate tests or prior experience. Apply primer to comply with joint-sealant manufacturer's written instructions. Confine primers to areas of joint-sealant bond; do not allow spillage or migration onto adjoining surfaces.
- C. Masking Tape: Use masking tape where required to prevent contact of sealant with adjoining surfaces that otherwise would be permanently stained or damaged by such contact or by cleaning methods required to remove sealant smears. Remove tape immediately after tooling without disturbing joint seal.

3.2 INSTALLATION

- A. Sealant Installation Standard: Comply with recommendations in ASTM C 1193 for use of joint sealants as applicable to materials, applications, and conditions indicated.
- B. Install sealant backings of type indicated to support sealants during application and at position required to produce cross-sectional shapes and depths of installed sealants relative to joint widths that allow optimum sealant movement capability.
 - 1. Do not leave gaps between ends of sealant backings.
 - 2. Do not stretch, twist, puncture, or tear sealant backings.
 - 3. Remove absorbent sealant backings that have become wet before sealant application and replace them with dry materials.
- C. Install bond-breaker tape behind sealants where sealant backings are not used between sealants and backs of joints.
- D. Install sealants using proven techniques that comply with the following and at the same time backings are installed:

1. Place sealants so they directly contact and fully wet joint substrates.
 2. Completely fill recesses in each joint configuration.
 3. Produce uniform, cross-sectional shapes and depths relative to joint widths that allow optimum sealant movement capability.
- E. Tooling of Nonsag Sealants: Immediately after sealant application and before skinning or curing begins, tool sealants according to requirements specified below to form smooth, uniform beads of configuration indicated; to eliminate air pockets; and to ensure contact and adhesion of sealant with sides of joint.
1. Remove excess sealant from surfaces adjacent to joints.
 2. Use tooling agents that are approved in writing by sealant manufacturer and that do not discolor sealants or adjacent surfaces.
 3. Provide concave joint configuration per Figure 5A in ASTM C 1193, unless otherwise indicated.
- F. Clean off excess sealant or sealant smears adjacent to joints as the Work progresses by methods and with cleaning materials approved in writing by manufacturers of joint sealants and of products in which joints occur.

3.3 JOINT-SEALANT SCHEDULE

- A. Joint-Sealant Application: Exterior perimeter joints at frames of doors, windows and louvers:
1. Product: Single-component nonsag urethane sealant:
 - a. Sonneborne NP-1
 - b. Tremco Vulkem 116
 - c. Sika Corp, Sika Flex, IA
 2. Joint-Sealant Color: Selected from manufacturer's standard colors.
- B. Joint-Sealant Application: Vertical control and expansion joints on exposed interior surfaces of exterior walls.
1. Product: Single-component nonsag urethane sealant:
 - a. Sonneborn NP-1
 - b. Tremco Vulkem 116
 - c. Sika Corp, Sika Flex, IA
 2. Joint-Sealant Color: Selected from manufacturer's standard colors.
- C. Joint-Sealant Application: Interior joints between plumbing fixtures and adjoining walls, floors, and counters.
1. Product: Single-component mildew-resistant neutral-curing silicone sealant.
 - a. Sonneborn Omniplus
 - b. GE Silicone Sanitary SCS 1700
 - c. Tremco Trement 200
 2. Joint-Sealant Color: Selected from manufacturer's standard colors.
- D. Joint-Sealant Application: Vertical joints on exposed surfaces of interior masonry and concrete, walls and partitions.

1. Product: Single component nonsag urethane sealant:
 - a. Sonneborn NP-1
 - b. Tremco Vulkem 116
 - c. Sika Corp, Sikaflex, IA
2. Joint-Sealant Color: Selected from manufacturer's standard colors.

E. Joint-Sealant Application: Perimeter joints between interior wall surfaces and frames of interior doors windows.

1. Product:
 - a. Sonneborn Sonolac
 - b. Tremco Tremflex 834
 - c. Pecora Corp AC-20.
2. Joint-Sealant Color: Selected from manufacturer's standard colors.

END OF SECTION 079200

SECTION 081113 - HOLLOW METAL DOORS AND FRAMES

PART 1 - GENERAL

1.1 SUMMARY

A. Section Includes:

1. Standard hollow metal doors and frames.
2. Extent of steel doors and frames is indicated and scheduled on the drawings.

B. Related Sections:

1. Division 04 Section "Unit Masonry Assemblies" for embedding anchors for hollow metal work into masonry construction.
2. Division 08 Section "Door Hardware" for door hardware for hollow metal doors.
3. Division 09 Section "Painting" for field painting hollow metal doors and frames.
4. Division 26 Sections for electrical connections including conduit and wiring for door controls and operators.

1.2 SUBMITTALS

A. Product Data: For each type of product indicated.

B. Shop Drawings: Include frame type and door type elevations, door edge details, frame profiles, metal thicknesses, preparations for hardware, conditions at each opening, and other details.

C. Indicate coordination of glazing frames and stops with Division 08 Section "Glass and Glazing."

D. Samples for Initial Selection: For units with factory-applied color finishes.

E. Samples for Verification: For each type of exposed finish required.

F. Schedule: Prepared by or under the supervision of supplier, using same reference numbers for details and openings as those on Drawings.

1.3 QUALITY ASSURANCE

A. Fire-Rated Door Assemblies: Assemblies complying with NFPA 80 that are listed and labeled by a qualified testing agency, for fire-protection ratings indicated, based on testing at positive pressure according to NFPA 252.

B. Fire-Rated, Borrowed-Light Frame Assemblies: Assemblies complying with NFPA 80 that are listed and labeled, by a testing and inspecting agency acceptable to authorities having jurisdiction, for fire-protection ratings indicated, based on testing according to NFPA 257 or UL 9. Label each individual glazed lite.

1. Refer to Division 08 Section “Flush Wood Doors” for products used with frame assemblies specified.
 2. At stairwell enclosures, provide doors that have a Temperature Rise rating required by the governing codes for the project’s geographic location.
- C. Smoke-Control Door Assemblies: Comply with NFPA 105 or UL 1784.

1.4 DELIVERY, STORAGE AND HANDLING

- A. Inspect hollow metal work upon delivery for damage. Minor defects may be repaired provided refinished items are equal in all respects to new work and acceptable to the Architect; otherwise, remove and replace damaged items.

PART 2 - PRODUCTS

2.1 MANUFACTURERS

- A. Manufacturers: Subject to compliance with requirements, provide products by one of the following:
1. Amweld Builders.
 2. Ceco Door Products; an Assa Abloy Group Company.
 3. Curries Company, an Assa Abloy Group Company.
 4. Mesker Door Inc.
 5. Pioneer Industries, Inc.
 6. Steelcraft; an Ingersoll-Rand company.
 7. Windsor Republic Doors.

2.2 MATERIALS

- A. Cold-Rolled Steel Sheet: ASTM A 1008/A 1008M, CS, Type B; suitable for exposed applications.
- B. Hot-Rolled Steel Sheet: ASTM A 1011/A 1011M, CS, Type B.
- C. Metallic-Coated Steel Sheet: ASTM A 653/A 653M, Commercial Steel (CS), Type B; with minimum A60 metallic coating, mill phosphatized.
- D. Frame Anchors: ASTM A 591/A 591M, Commercial Steel (CS), 40Z coating designation; mill phosphatized.
1. For anchors built into exterior walls, steel sheet complying with ASTM A 1008/A 1008M or ASTM A 1011/A 1011M, hot-dip galvanized according to ASTM A 153/A 153M, Class B.
- E. Inserts, Bolts, and Fasteners: Manufacturer’s standard, except Hot-dip galvanized for exterior walls and interior Natatorium and Pool Chemical Room walls according to ASTM A 153/A 153M.

- F. Grout: ASTM C 476, except with a maximum slump of 4 inches, as measured according to ASTM C 143/C 143M.
- G. Mineral-Fiber Insulation: ASTM C 665, Type I.
- H. Glazing: Division 08 Section "Glass and Glazing."
- I. Bituminous Coating: Cold-applied asphalt mastic, SSPC-Paint 12, compounded for 15-mil dry film thickness per coat.
- J. Primer: Rust-inhibitive epoxy primer compatible with Division 09 "Painting."

2.3 STANDARD HOLLOW METAL DOORS

- A. General: Comply with ANSI/SDI A250.8. Fabricate free from defects, warp or buckle. Fully assemble in manufacturer's plant where practical. Clearly identify work that cannot be fully assembled and provide instructions for completion in the field.
 - 1. Design: Flush panel.
 - 2. Core Construction: Manufacturer's standard kraft-paper honeycomb, polystyrene, polyurethane, polyisocyanurate, mineral-board, or vertical steel-stiffener core.
 - a. Fire Door Core: As required to provide fire-protection ratings indicated.
 - b. Thermal-Rated (Insulated) Doors: R-value of not less than 6.0 deg F x h x sq. ft./Btu when tested according to ASTM C 1363.
 - 3. Vertical Edges for Single-Acting Doors: Square edge.
 - 4. Top and Bottom Edges: Closed with flush 0.042-inch- thick, end closures or channels of same material as face sheets.
 - 5. Tolerances: SDI 117, "Manufacturing Tolerances for Standard Steel Doors and Frames".
- B. Exterior Doors: Face sheets fabricated from metallic-coated steel sheet. Comply with ANSI/SDI A250.8 for level and model and ANSI/SDI A250.4 for physical performance level:
 - 1. Level 4, physical performance Level A, Model 2 with thermal insulation, minimum 14-gage faces (seamless with no face or vertical edge seams).
 - 2. Thermally-Rated Assemblies: ASTM C 236, with minimum U-factor of 0.24 BTU/(hr./ft.sq./deg F.) or better.
- C. Interior Doors: Face sheets fabricated from cold-rolled steel sheet or metallic-coated steel sheet. Provide doors complying with requirements indicated below by referencing ANSI/SDI A250.8 for level and model and ANSI/SDI A250.4 for physical performance level:
 - 1. Level 3 or 4, physical performance level A, Model 2 minimum 16-gage faces (seamless with no face or vertical edge seams).
 - 2. Interior doors exposed to Natatorium environment, wet environments, and exposed to caustic chemical rooms to be fabricated with metallic-coated steel sheet.

- D. Hardware Reinforcement: ANSI/SDI A250.6.

2.4 STANDARD HOLLOW METAL FRAMES

- A. General: Comply with ANSI/SDI A250.8. Fabricate frames to be rigid, neat in appearance, and free from defects, warp or buckle, including installation. Preassemble frames in manufacturer's plant wherever practical.
- B. Exterior Frames [and interior frames exposed to Natatorium, wet environments, and caustic pool chemical areas]: Fabricated from metallic-coated steel sheet.
 - 1. Fabricate frames with mitered or coped corners.
 - 2. Fabricate frames as full profile welded unless otherwise indicated. Knock down frames are not acceptable.
 - 3. Frames for Level 4 Steel Doors: 0.067-inch- thick steel sheet (14 gage).
- C. Interior Frames: Fabricated from cold-rolled steel sheet.
 - 1. Fabricate frames with mitered or coped corners.
 - 2. Fabricate frames as full profile welded unless otherwise indicated. Knock down frames are acceptable for interior stud walls.
 - 3. Frames for Level 3 Steel Doors: 0.053-inch- thick steel sheet (16 gage).
 - 4. Frames for Level 4 Steel Doors: 0.067-inch- thick steel sheet (14 gage).
 - 5. Frames for Borrowed Lights: 0.067-inch- thick steel sheet.
- D. Hardware Reinforcement: ANSI/SDI A250.6.
- E. Door silencers: Except on weatherstripped frames, drill stops to receive silencers on strike side of jambs. [HC]

2.5 FRAME ANCHORS

- A. Jamb Anchors:
 - 1. Masonry Type: Adjustable strap-and-stirrup or T-shaped anchors to suit frame size, not less than 0.042 inch thick, with corrugated or perforated straps not less than 2 inches wide by 10 inches long; or wire anchors not less than 0.177 inch thick.
 - 2. Stud-Wall Type: Designed to engage stud, welded to back of frames; not less than 0.042 inch thick.
 - 3. Postinstalled Expansion Type for In-Place Concrete or Masonry: Minimum 3/8-inch-diameter bolts with expansion shields or inserts. Provide pipe spacer from frame to wall, with throat reinforcement plate, welded to frame at each anchor location.
 - 4. Use stainless steel anchors for frames requiring metallic-coated sheet steel.
- B. Floor Anchors: Formed from same material as frames, not less than 0.042 inch thick, and as follows:
 - 1. Monolithic Concrete Slabs: Clip-type anchors, with two holes to receive fasteners.

2.6 STOPS AND MOLDINGS

- A. Moldings for Glazed Lites in Doors: Minimum 0.032-inch thick, same material as door face sheet.
- B. Fixed Frame Moldings: Formed integral with hollow metal frames, a minimum of 5/8 inch high unless otherwise indicated.
- C. Loose Stops for Glazed Lites in Frames: Minimum 0.032-inch thick, same material as frames.

2.7 ACCESSORIES

- A. Mullions and Transom Bars: Join to adjacent members by welding or rigid mechanical anchors.
- B. Grout Guards: Formed from same material as frames, not less than 0.016-inch thick.

2.8 FABRICATION

- A. Tolerances: Fabricate hollow metal work to tolerances indicated in SDI 117.
- B. Hollow Metal Doors:
 - 1. Exterior Doors: Provide weep-hole openings in bottom of exterior doors. Seal joints in top edges of doors against water penetration.
 - 2. Glazed Lites: Factory cut openings in doors.
 - 3. Astragals: Provide overlapping astragal on one leaf of pairs of doors where required by NFPA 80 for fire-performance rating or where indicated.
- C. Hollow Metal Frames: Where frames are fabricated in sections, provide alignment plates or angles at each joint, fabricated of same thickness metal as frames.
 - 1. Welded Frames: Weld flush face joints continuously; grind, fill, dress, and make smooth, flush, and invisible.
 - 2. Sidelight Frames: Provide closed tubular members with no visible face seams or joints, fabricated from same material as doorframe. Fasten members at crossings and to jambs by butt welding.
 - 3. Provide countersunk, flat- or oval-head exposed screws and bolts for exposed fasteners unless otherwise indicated.
 - 4. Grout Guards: Weld guards to frame at back of hardware mortises in frames to be grouted.
 - 5. Floor Anchors: Weld anchors to bottom of jambs and mullions with at least four spot welds per anchor.
 - 6. Jamb Anchors: Provide number and spacing of anchors as follows:
 - a. Masonry Type: Locate anchors not more than 18 inches from top and bottom of frame. Space anchors not more than 32 inches o.c. and as follows:
 - 1) Two anchors per jamb up to 60 inches high.
 - 2) Three anchors per jamb from 60 to 90 inches high.
 - 3) Four anchors per jamb from 90 to 120 inches high.

- 4) Four anchors per jamb plus 1 additional anchor per jamb for each 24 inches or fraction thereof above 120 inches high.
 - b. Stud-Wall Type: Locate anchors not more than 18 inches from top and bottom of frame. Space anchors not more than 32 inches o.c. and as follows:
 - 1) Three anchors per jamb up to 60 inches high.
 - 2) Four anchors per jamb from 60 to 90 inches high.
 - 3) Five anchors per jamb from 90 to 96 inches high.
 - 4) Five anchors per jamb plus 1 additional anchor per jamb for each 24 inches or fraction thereof above 96 inches high.
 - 5) Two anchors per head for frames more than 42 inches wide and mounted in metal-stud partitions.
 - c. Compression Type: Not less than two anchors in each jamb.
 - d. Postinstalled Expansion Type: Locate anchors not more than 6 inches from top and bottom of frame. Space anchors not more than 26 inches o.c.
- 7. Door Silencers: Except on weather-stripped doors, drill stops to receive door silencers.
 - a. Single-Door Frames: Three door silencers.
 - b. Double-Door Frames: Two door silencers per door along head rail.
- D. Hardware Preparation: Factory prepare hollow metal work to receive templated mortised hardware according to the Door Hardware Schedule and templates furnished as specified in Division 08 Section "Door Hardware."
 - 1. Locate hardware as indicated, or if not indicated, according to ANSI/SDI A250.8.
 - 2. Reinforce doors and frames to receive nontemplated, mortised and surface-mounted door hardware.
 - 3. Comply with applicable requirements in ANSI/SDI A250.6 and ANSI/DHI A115 Series specifications for preparation of hollow metal work for hardware.
 - 4. Coordinate locations of conduit and wiring boxes for electrical connections with Division 26 electrical Sections.
- E. Stops and Moldings: Provide stops and moldings around glazed lites where indicated. Form corners of stops and moldings with butted or mitered hairline joints.
 - 1. Single Glazed Lites: Provide fixed stops and moldings welded on secure side of hollow metal work.
 - 2. Multiple Glazed Lites: Provide fixed and removable stops and moldings so that each glazed lite is capable of being removed independently.
 - 3. Provide fixed frame moldings on outside of exterior and on secure side of interior doors and frames.
 - 4. Provide loose stops and moldings on inside of hollow metal work.
 - 5. Coordinate rabbet width between fixed and removable stops with type of glazing and type of installation indicated.

2.9 STEEL FINISHES

- A. Prime Finish: Apply primer immediately after cleaning and pretreating.
 - 1. Shop Primer: Meet the performance requirements of Division 09 Section "Painting".
 - 2. Primer to be compatible with field applied finish coats specified without the need of a barrier coat.

PART 3 - EXECUTION

3.1 INSTALLATION

- A. Hollow Metal Frames: Comply with ANSI/SDI A250.11.
 - 1. Set frames accurately in position, plumbed, aligned, and braced securely until permanent anchors are set. After wall construction is complete, remove temporary braces, leaving surfaces smooth and undamaged.
 - a. At fire-protection-rated openings, install frames according to NFPA 80.
 - b. Where frames are fabricated in sections because of shipping or handling limitations, field splice at approved locations by welding face joint continuously; grind, fill, dress, and make splice smooth, flush, and invisible on exposed faces.
 - c. Install frames with removable glazing stops located on secure side of opening.
 - d. Install door silencers in frames before grouting.
 - e. Remove temporary braces necessary for installation only after frames have been properly set and secured.
 - f. Check plumbness, squareness, and twist of frames as walls are constructed. Shim as necessary to comply with installation tolerances.
 - g. Field apply bituminous coating to backs of frames that are filled with grout containing antifreezing agents.
 - 2. Floor Anchors: Provide floor anchors for each jamb and mullion that extends to floor, and secure with postinstalled expansion anchors.
 - a. Floor anchors may be set with powder-actuated fasteners instead of postinstalled expansion anchors if so indicated and approved on Shop Drawings.
 - 3. Metal-Stud Partitions: Solidly pack mineral-fiber insulation behind frames.
 - 4. Masonry Walls: Coordinate installation of frames to allow for solidly filling space between frames and masonry with grout.
 - 5. In-Place Concrete or Masonry Construction: Secure frames in place with postinstalled expansion anchors. Countersink anchors, and fill and make smooth, flush, and invisible on exposed faces.
 - 6. In-Place Gypsum Board Partitions: Secure frames in place with postinstalled expansion anchors through floor anchors at each jamb. Countersink anchors, and fill and make smooth, flush, and invisible on exposed faces.
 - 7. Installation Tolerances: Adjust hollow metal door frames for squareness, alignment, twist, and plumb to the following tolerances:

- a. Squareness: Plus or minus 1/16 inch, measured at door rabbet on a line 90 degrees from jamb perpendicular to frame head.
 - b. Alignment: Plus or minus 1/16 inch, measured at jambs on a horizontal line parallel to plane of wall.
 - c. Twist: Plus or minus 1/16 inch, measured at opposite face corners of jambs on parallel lines, and perpendicular to plane of wall.
 - d. Plumbness: Plus or minus 1/16 inch, measured at jambs at floor.
- B. Hollow Metal Doors: Fit hollow metal doors accurately in frames, within clearances specified below. Shim as necessary.
1. Non-Fire-Rated Standard Steel Doors:
 - a. Jambs and Head: 1/8 inch plus or minus 1/16 inch.
 - b. Between Edges of Pairs of Doors: 1/8 inch plus or minus 1/16 inch.
 - c. Between Bottom of Door and Top of Threshold: Maximum 3/8 inch.
 - d. Between Bottom of Door and Top of Finish Floor (No Threshold): Maximum 3/4 inch.
 2. Fire-Rated Doors: Install doors with clearances according to NFPA 80.
- C. Glazing: Comply with installation requirements in Division 08 Section "Glazing" and with hollow metal manufacturer's written instructions.
1. Secure stops with countersunk flat- or oval-head machine screws spaced uniformly not more than 9 inches o.c. and not more than 2 inches o.c. from each corner.

3.2 ADJUSTING AND CLEANING

- A. Final Adjustments: Check and readjust operating hardware items immediately before final inspection. Leave work in complete and proper operating condition. Remove and replace defective work, including hollow metal work that is warped, bowed, or otherwise unacceptable.
- B. Prime-Coat Touchup: Immediately after erection, sand smooth rusted or damaged areas of prime coat and apply touchup of compatible air-drying, rust-inhibitive primer.
- C. Metallic-Coated Surfaces: Clean abraded areas and repair with galvanizing repair paint according to manufacturer's written instructions.

END OF SECTION 081113

SECTION 081416 - FLUSH WOOD DOORS

PART 1 - GENERAL

1.1 RELATED DOCUMENTS

- A. Drawings and general provisions of the Contract, including the General and Supplementary Conditions and Division 01 Specification Sections, apply to this Section.

1.2 SUMMARY

- A. This Section includes solid core wood doors with wood veneer faces.
- B. Factory finishing of flush wood doors.
- C. Factory machining for hardware.

1.3 RELATED SECTIONS

- A. Division 8 Section "Door Hardware" for hardware requirements.
- B. Division 8 Section "Glazing" for vision panels in doors.

1.4 SUBMITTALS

- A. General: Submit each item in this Article according to the Conditions of the Contract and Division 01 Specification Sections.
- B. Product data for each type of door, including details of core and edge construction, trim for openings and factory-finishing specifications.
- C. Shop drawings indicating location and size of each door, elevation of each kind of door, details of construction, location and extent of hardware blocking, fire ratings, requirements for veneer matching and factory finishing and other pertinent data.
 - 1. For factory-machined doors, indicate dimensions and locations of cutouts for locksets and other cutouts adjacent to light openings.
- D. Samples for initial selection in the form of color charts consisting of actual materials in small sections for the following:
 - 1. Faces of factory-finished doors with transparent finish. Show the full range of colors available for stained finishes.
 - 2. Certification of Veneer to be submitted in writing by Wood Veneer manufacturer that the face veneers are the grade specified. Certification to be submitted accompanied by Door manufacturer statement that doors are faced with specified veneers.

E. Samples for verification - Provide form and size indicated below:

1. Provide four sets of two samples of unfinished veneer mounted on plywood approximately 12 inches (300 mm) square illustrating expected range of veneer color and grain illustrating allowable inclusions, mineral streaks, vinemarks, cross bars, birdseye, sugartracks, wormtracks, gumpockets, barkpockets, and other imperfections. Architect shall judge the acceptable variations to be slight or occasional.
2. Provide four sets of two samples the Corner sections of doors approximately 12 inches (300 mm) square with door faces depicting door construction and edgings and representing the typical range of door finish color for each species of veneer and solid lumber required. Finish sample with same materials proposed for factory-finished doors.
3. One approved set of each type of samples shall be retained and serve as range samples for wood veneer grade and finish. Doors delivered to project but not falling within range shall not be acceptable.
4. Frames for light openings, 6 inches (150 mm) long, for each material, type, and finish required.

1.5 QUALITY ASSURANCE

A. Quality Standard: Comply with the following standard:

1. WDMA; "Window and Door Manufacturing Association" WDMA I.S. 1A-04 for grade of door, core, finish, construction, and other requirements.
2. AWI, "Architectural Woodworking Institute" and 7th ed. Architectural Woodwork Quality Standards, Section 1300 for specific doors standards as indicated. AWI Standards to be used with doors in conjunction with wood paneling specified in Division 6 "Interior Architectural Woodwork." Face veneers of doors within blueprinted assemblies shall match the veneer and finish requirements for paneling.

B. Fire-Rated Wood Doors: Provide wood doors that comply with NFPA 252; are identical in materials and construction to units tested in door and frame assemblies per ASTM E 152; and are labeled and listed by UL, Warnock Hersey, or another testing and inspection agency acceptable to authorities having jurisdiction.

1. Oversized, Fire-Rated Wood Doors: For door assemblies exceeding sizes of tested assemblies, provide manufacturer's certificate stating that doors conform to all standard construction requirements of tested and labeled fire-door assemblies except for size.
2. Temperature Rise Rating: At stairwell enclosures, provide doors that have a temperature rise rating of 450 deg F (232 deg C) maximum in 30 minutes of fire exposure.

C. Single-Source Responsibility: Obtain flush wood doors from one source and by a single manufacturer.

1.6 DELIVERY, STORAGE, AND HANDLING

A. Protect doors during transit, storage, and handling to prevent damage, soiling, and deterioration. Comply with requirements of referenced standard and manufacturer's instructions.

- B. Identify each door with individual opening numbers as designated on shop drawings, using temporary, removable, or concealed markings.

1.7 PROJECT CONDITIONS

- A. Conditioning: Do not deliver or install doors until conditions for temperature and relative humidity have been stabilized and will be maintained in storage and installation areas during the remainder of the construction period to comply with the following requirements applicable to Project's geographical location:
 - 1. WDMA I.S. 1A-04: J-1 Job Site Information, and AWI Section 100-S-11 "Moisture and Relative Humidity."

1.8 WARRANTY

- A. General Warranty: Door manufacturer's warranty specified in this Article shall not deprive the Owner of other rights the Owner may have under other provisions of the Contract Documents and shall be in addition to, and run concurrent with, other warranties made by the Contractor under requirements of the Contract Documents.
- B. Door Manufacturer's Warranty: Submit written agreement on door manufacturer's standard form signed by manufacturer, Installer, and Contractor, agreeing to repair or replace defective doors that have warped (bow, cup, or twist) more than 1/4 inch in a 42-by-84-inch section or that show telegraphing of core construction in face veneers exceeding 0.01 inch in a 3-inch span, or do not conform to tolerance limitations of referenced quality standards.
 - 1. Warranty shall also include installation and finishing that may be required due to repair or replacement of defective doors where defect was not apparent prior to hanging.
 - 2. Warranty shall be in effect during the Life of Installation after date of Final Acceptance.

PART 2 - PRODUCTS

2.1 MANUFACTURERS

- A. Manufacturer: Subject to compliance with requirements, provide doors by one of the following manufacturers. Products of listed manufacturers, which do not meet all specified requirements will not be acceptable.
 - 1. Algoma Hardwoods Inc.
 - 2. Eggers Industries; Architectural Door Div.
 - 3. Graham Wood Doors.
 - 4. IPIK Door Company.
 - 5. VT Industries Inc.

2.2 INTERIOR HALF AND FULL LITE DOORS

- A. Manufacturer: Subject to compliance with requirements, provide doors by manufacturer's who will provide a 'Full Lite/Full Warranty for doors with 6-inch wide timber strand core stiles.

2.3 INTERIOR FLUSH WOOD DOORS

- A. Non-Rated Solid Core Doors for Transparent Finish: Comply with the following requirements for WDMA "Heavy Duty" Door WDMA Symbol PC-5.

1. Faces: Plain sliced, 'Select' White Maple.
2. Grade: Premium, Grade 'A' Face Veneer – book matching.
3. Construction: Manufacturer's standard 5 plies.
4. Core: Particleboard core.
5. Bonding: Stiles and rails bonded to core, then entire unit abrasive planed before veneering.
6. Edges: Same species (ME) or compatible hardwood (CE).

- B. Fire-Rated Solid Core Doors: Comply with the following requirements:

1. Faces and Grade: Provide faces and grade to match non-fire-rated doors in same area of building, unless otherwise indicated.
2. Construction: Manufacturer's standard core construction as required to provide fire-resistance rating indicated.
3. Blocking: Provide optional composite blocking designed to maintain fire resistance of door but with improved screw-holding capability of same thickness as core. Locate blocking at all hardware points.
4. Coordinate blocking requirements with Hardware Schedule at end of Section 087100.
5. Edge Construction: Provide manufacturer's standard laminated-edge construction for improved screw-holding capability and split resistance as compared to edges composed of a single layer of treated lumber.
6. Pairs: Equip fire-rated pairs receiving exit devices with edges which are labeled and listed for kinds of applications indicated without overlapping astragals.

2.4 VENEER MATCHING

- A. Within Door Faces: Provide doors with the following veneer matching:

1. Book matching.

- B. Pairs and Sets: Provide pair matching and set matching for pairs of doors and for doors hung in adjacent sets.

- C. Doors with Transoms (as occurs): Provide the following matching:

1. Continuous matching.

2.5 LIGHT FRAMES

- A. Metal Frames for Light Openings in Fire Doors: Manufacturer's standard frame formed of 0.0478-inch- (1.2-mm) thick cold-rolled steel sheet, factory primed, and approved for use in doors of fire rating indicated.
- B. Wood Molding for Light Openings in Non-Rated Doors: Provide door manufacturer's standard matching wood door molding.

2.6 FABRICATION

- A. Fabricate flush wood doors to comply with following requirements:
- B. Factory fit doors to suit frame-opening sizes indicated, with the following uniform clearances and bevels:
 - 1. Comply with clearance requirements of referenced quality standard for fitting. Comply with requirements of NFPA 80 for fire-resistance-rated doors.
 - 2. Provide undercut doors where indicated and where not indicated, for ventilation at all toilet, shower, and data closet rooms.
- C. Factory machine doors for hardware that is not surface applied. Locate hardware to comply with DHI-WDHS-3. Comply with final hardware schedules, doorframe shop drawings, DHI A115-W series standards, and hardware templates.
 - 1. Coordinate measurements of hardware mortises in metal frames to verify dimensions and alignment before proceeding with factory machining.
- D. Transom and Side Panels: Fabricate matching panels with same construction, exposed surfaces, and finish as specified for associated doors. Fabricate fixed panels with solid lumber transom bottom rail and door top rail, both rabbeted. Provide factory-installed spring bolts for concealed attachment into jambs of metal doorframes.
- E. Openings: Cut and trim openings through doors to comply with applicable requirements of referenced standards for kind(s) of door(s) required.
 - 1. Light Openings: Trim openings with specified light frames.

2.7 FACTORY FINISHING

- A. General: Comply with referenced quality standard's requirements for factory finishing.
- B. Finish wood doors at factory.
- C. Transparent Finish: Comply with requirements indicated for grade, finish system, staining effect, and sheen.
 - 1. Grade: Premium, Grade 'A' face veneer.
 - 2. Finish: System TR-6 catalyzed polyurethane.
 - 3. Staining: Match Architects sample.

4. Effect: Open-grain finish.
5. Sheen: Satin, no more than 40.
6. Color: As indicated by manufacturer's finish number in Finish and Color Schedules.

PART 3 - EXECUTION

3.1 EXAMINATION

- A. Examine installed doorframes prior to hanging door:
 1. Verify that frames comply with indicated requirements for type, size, location, and swing characteristics and have been installed with plumb jambs and level heads.
 2. Reject doors with defects.
 3. Do not proceed with installation until unsatisfactory conditions have been corrected.

3.2 INSTALLATION

- A. Hardware: For installation see Division 08 Section "Door Hardware."
- B. Manufacturer's Instructions: Install wood doors to comply with manufacturer's instructions and referenced quality standard and as indicated.
 1. Install fire-rated doors in corresponding fire-rated frames according to requirements of NFPA 80.
- C. Factory-Fitted Doors: Align in frames for uniform clearance at each edge.
- D. Factory-Finished Doors: Restore finish before installation, if fitting or machining is required at the job site.

3.3 ADJUSTING AND PROTECTION

- A. Operation: Re-hang or replace doors that do not swing or operate freely.
- B. Finished Doors: Refinish or replace doors damaged during installation.
- C. Protect doors as recommended by door manufacturer to ensure that wood doors will be without damage or deterioration at the time of Final Acceptance.

END OF SECTION 081416

SECTION 084113 - ALUMINUM ENTRANCES AND STOREFRONT

PART 1 - GENERAL

1.1 RELATED DOCUMENTS

- A. Drawings and general provisions of Contract, including General and Supplementary Conditions and Division 01 Specification Sections, apply to this Section.

1.2 SUMMARY

- A. This Section includes the following types of aluminum entrance and storefront work:
 - 1. Storefront-type framing system.
 - 2. Exterior windows.
- B. Related Sections: The following sections contain requirements that relate to this Section:
 - 1. Division 8 Section, "Glazing" for glazing requirements for aluminum entrances and storefront, including entrances specified to be factory glazed.

1.3 SYSTEM PERFORMANCE REQUIREMENTS

- A. Structural Loading: Aluminum entrances and storefront shall be designed to resist loading as calculated by ASCE 7-10 based upon loading as specified on **drawing S1.01**.
- B. General: Provide aluminum entrance and storefront assemblies that comply with performance characteristics specified, as demonstrated by testing the manufacturer's corresponding stock assemblies according to test methods indicated:
- C. Air Infiltration Entrance Doors and Frames: Provide aluminum entrance doors with an air infiltration rate of not more than 0.5 CFM per lin. ft. of perimeter crack when tested in accordance with ASTM E 283 at an inward test pressure differential of 6.24 psf.
- D. Air Infiltration: Provide aluminum-framed systems with maximum air leakage through fixed glazing and framing areas of 0.06 cfm/sq. ft. of fixed wall area when tested according to ASTM E 283 at a minimum static-air-pressure difference of 6.24 lbf/sq. ft.
- E. Water Penetration under Static Pressure: Provide aluminum-framed systems that do not evidence water penetration through fixed glazing and framing areas when tested according to ASTM E 331 at a minimum static-air-pressure difference of 20 percent of positive wind-load design pressure, but not less than 30 lbf/sq. ft.

1.4 SUBMITTALS

- A. General: Submit the following in accordance with Conditions of the Contract and Division 01 Specification Sections:
 - 1. Provide calculations from the manufacturer supporting the system as designed meets the specified loading per ASCE 7-10 as indicated on drawing **S1.01**. If manufacturer cannot provide calculations, provide structural analysis calculations signed and sealed by a qualified structural engineer registered in the state of North Carolina. Analysis shall include sealed ASCE 7-10 calculations.
 - 2. Product data for each aluminum entrance and storefront system required, including:
 - 3. Manufacturer's standard details and fabrication methods.
 - 4. Data on finishing, hardware and accessories.
 - 5. Recommendations for maintenance and cleaning of exterior surfaces.

- B. Shop drawings for each aluminum entrance and storefront system required, including:
 - 1. Layout and installation details, including relationship to adjacent work.
 - 2. Elevations at 1/4-inch scale.
 - 3. Detail sections of typical composite members.
 - 4. Anchors and reinforcement.
 - 5. Hardware mounting heights.
 - 6. Provisions for expansion and contraction.
 - 7. Glazing details.

- C. Samples for Initial Color Selection: Submit pairs of samples of each specified color and finish on 12-inch-long sections of extrusions or formed shapes. Where normal color variations are anticipated, include 2 or more units in each set of samples indicating extreme limits of color variations.

- D. Samples for Verification Purposes: The Architect reserves the right to require additional samples, that show fabrication techniques and workmanship, and design of hardware and accessories.

- E. Test Reports: Provide certified test reports from a qualified independent testing laboratory showing that aluminum entrance and storefront systems have been tested in accordance with specified test procedures and comply with performance characteristics indicated.

1.5 QUALITY ASSURANCE

- A. Installer Qualifications: Engage an experienced Installer who has completed installations of aluminum storefront and entrances similar in design and extent to those required for the project and whose work has resulted in construction with a record of successful in-service performance.

- B. Manufacturer's Qualifications: Provide aluminum entrances and storefront systems produced by a firm experienced in manufacturing systems that are similar to those indicated for this project and that have a record of successful in-service performance.

- C. Fabricator Qualifications: Provide aluminum entrances and storefront systems fabricated by a firm experienced in producing systems that are similar to those indicated for this project, and that have a record of successful in-service performance. The fabricator shall have sufficient production capacity to produce components required without causing delay in progress of the Work.

- D. Single Source Responsibility: Obtain aluminum entrance and storefront systems from one source and from a single manufacturer.

1.6 DELIVERY, STORAGE, AND HANDLING

- A. Deliver aluminum entrance and storefront components in the manufacturer's original protective packaging.
- B. Store aluminum components in a clean dry location away from uncured masonry or concrete. Cover components with waterproof paper, tarpaulin or polyethylene sheeting in a manner to permit circulation of air. Stack framing components in a manner that will prevent bending and avoid significant or permanent damage.

1.7 PROJECT CONDITIONS

- A. Field Measurements: Check openings by accurate field measurement before fabrication. Show recorded measurements on shop drawings. Coordinate fabrication schedule with construction progress to avoid delay of work. Where necessary, proceed with fabrication without field measurements, and coordinate fabrication tolerances to ensure proper fit.
- B. Warranty: Submit a written warranty, executed by the manufacturer, agreeing to repair or replace units that fail in materials or workmanship within the specified warranty period. Failures include, but are not necessarily limited to:
 - 1. Structural failures including excessive deflection, excessive leakage or air infiltration.
 - 2. Faulty operation.
 - 3. Deterioration of metals, metal finishes and other materials beyond normal weathering.
- C. Warranty Period: Storefront - 2 years after the date of final acceptance and the Entrance Door corner construction shall carry a Manufacturers Limited Lifetime Warranty. The warranty shall not deprive the College of other rights or remedies the College may have under other provisions of the Contract Documents and is in addition to and runs concurrent with other warranties made by the Contractor under requirements of the Contract Documents.

PART 2 - PRODUCTS

2.1 MANUFACTURERS

- A. Basis of Design: Systems and profiles are based on Kawneer TriFab 451/451T Series. Interior vestibule frames to use same profile as exterior in 1" glazing units and as indicated. **Refer to Division 08 Section "Glazing."**
- B. Subject to compliance with requirements, provide comparable entrance and storefront systems manufactured by one of the following:

1. Kawneer
 2. EFCO
 3. YKK America
- C. Aluminum Members: Alloy and temper recommended by the manufacturer for strength, corrosion resistance, and application of required finish; comply with ASTM B 221 for aluminum extrusions, ASTM B 209 for aluminum sheet or plate, and ASTM B 221 for aluminum bars, rods and wire.
- D. Carbon steel reinforcement of aluminum framing members shall comply with ASTM A 36 for structural shapes, plates and bars, ASTM A 611 for cold rolled sheet and strip, or ASTM A 570 for hot rolled sheet and strip.
- E. Glass and Glazing Materials: Comply with requirements of "Glass and Glazing" section of these specifications.
- F. Fasteners: Provide fasteners of aluminum, nonmagnetic stainless steel, zinc-plated steel, or other material warranted by the manufacturer to be noncorrosive and compatible with aluminum components, hardware, anchors and other components.
- G. Reinforcement: Where fasteners screw-anchor into aluminum members less than 0.125 inches thick, reinforce the interior with aluminum or nonmagnetic stainless steel to receive screw threads, or provide standard noncorrosive pressed-in splined grommet nuts.
- H. Exposed Fasteners: Do not use exposed fasteners except for application of hardware. For application of hardware, use Phillips flat-head machine screws that match the finish of member or hardware being fastened.
- I. Concealed Flashing: 3/8" thermally broken extruded aluminum of alloy and type selected by manufacturer for compatibility with other components.
- J. Brackets and Reinforcements: Provide high-strength aluminum brackets and reinforcements; where use of aluminum is not feasible provide nonmagnetic stainless steel or hot-dip galvanized steel complying with ASTM A 123.
- K. Concrete and Masonry Inserts: Provide cast iron, malleable iron, or hot-dip galvanized steel inserts complying with ASTM A 123.
- L. Compression Weatherstripping: Manufacturer's standard replaceable compressible weatherstripping gaskets of molded EPDM complying with or molded PVC complying with ASTM D 2287.
- M. Sliding Weatherstripping: Manufacturer's standard replaceable weatherstripping of wool, polypropylene, or nylon woven pile, with nylon fabric or aluminum strip backing, complying with AAMA 701.2.

2.2 HARDWARE

A. Door Hardware

1. Door hardware shall be supplied by the hardware supplier and installed by the aluminum entrance and storefront supplier. Reference section 087100 for finish hardware provided by others. Coordinate hardware template requirements with the hardware supplier.

2.3 COMPONENTS

- A. Storefront Framing System: Provide storefront and entrance framing systems fabricated from extruded aluminum members of size and profile indicated. Include reinforcing members required for complete installation. Provide for flush glazing storefront from the interior on all sides without projecting stops. Shop-fabricate and pre-assemble frame components where possible. Provide storefront frame sections without exposed seams.
- B. Any design changes do to requirements of reinforcing shall be brought to the Architects attention and reviewed with the Architect for approval prior to fabrication.
- C. Mullion Configurations: Provide pockets at the inside glazing face to receive resilient elastomeric glazing. Make provisions to drain moisture accumulation to the exterior.
- D. Muntins: Aluminum extruded rectangular units in grid frame indicated, mounted inside the air space of the insulating glass units. Refer to drawings for frame elevations and muntin patterns.
- E. Entrance Door Frames: Provide tubular and channel frame entrance doorframe assemblies, as indicated, with welded or mechanical joints in accordance with manufacturer's standards. Reinforce as necessary to support required loads.
- F. Stile-and-Rail Type Entrance Doors: Provide tubular frame members, fabricated with mechanical joints using heavy inserted reinforcing plates and fully welded corners.
- G. Glazing: Fabricate doors to facilitate replacement of glass or panels, without disassembly of stiles and rails. Provide snap-on extruded aluminum glazing stops, with exterior stops anchored for non-removal.
- H. Design Criteria: The drawings indicate the size, profile, and dimensional requirements of aluminum entrance and storefront work required and are based on:
 1. Aluminum entrance and storefront systems by other manufacturers may be considered, provided deviations in dimensions and profiles are minor and do not change the design concept as judged by the Architect. The burden of proof of equality is on the proposer. Use of other manufacturers' products must be approved by the architect 10 days prior to the bid date.
- I. Entrance and Vestibule Doors: See Sliding Automatic Entrances 084232.
- J. Lights: Provide glazed openings as indicated, with aluminum moldings and stops. Provide non-removable stops on the exterior.

2.4 FABRICATION

- A. General: Fabricate aluminum entrance and storefront components to designs, sizes and thicknesses indicated and to comply with indicated standards. Sizes and profile requirements are indicated on the drawings. Variable dimensions are indicated, with maximum and minimum dimensions required, to achieve design requirements and coordination with other work.
- B. Prefabrication: Complete fabrication, assembly, finishing, hardware application, and other work to the greatest extent possible before shipment to the Project site. Disassemble components only as necessary for shipment and installation.
- C. Perform fabrication operations, including cutting, fitting, forming, drilling and grinding of metal work to prevent damage to exposed finish surfaces. Complete these operations for hardware prior to application of finishes.
- D. Do not drill and tap for surface-mounted hardware items until time of installation at project site.
- E. Pre-glaze door and frame units to greatest extent possible.
- F. Welding: Comply with AWS recommendations. Grind exposed welds smooth to remove weld spatter and welding oxides. Restore mechanical finish.
- G. Welding behind finished surfaces shall be performed in such a manner as to minimize distortion and discoloration on the finished surface.
- H. Reinforcing: Install reinforcing as required for hardware and as necessary for performance requirements, sag resistance and rigidity.
- I. Dissimilar Metals: Separate dissimilar metals with bituminous paint, or a suitable sealant, or a non-absorptive plastic or elastomeric tape, or a gasket between the surfaces. Do not use coatings containing lead.
- J. Continuity: Maintain accurate relation of planes and angles with hairline fit of contacting members.
- K. Uniformity of Metal Finish: Abutting extruded aluminum members shall not have an integral color or texture variation greater than half the range indicated in the sample pair submittal.
- L. Fasteners: Conceal fasteners wherever possible.
- M. Weatherstripping: For exterior doors, provide compression weatherstripping against fixed stops. At other edges, provide sliding weatherstripping retained in adjustable strip mortised into door edge.
- N. Provide EPDM-blade gasket weatherstripping in bottom door rail, adjustable for contact with threshold.
- O. At interior doors and other locations without weatherstripping, provide neoprene silencers on stops to prevent metal-to-metal contact.

2.5 FINISHES

- A. Anodized aluminum architectural class one, 0.7 mils minimum.
 - 1. Interior frame color: Permanadic: dark bronze.
 - 2. Exterior frame color: Permanadic: dark bronze.

PART 3 - EXECUTION

3.1 EXAMINATION

- A. Examine substrates and supports, with the Installer present, for compliance with requirements indicated, installation tolerances, and other conditions that affect installation of aluminum entrances and storefronts. Correct unsatisfactory conditions before proceeding with the installation.
- B. Do not proceed with installation until unsatisfactory conditions are corrected.

3.2 INSTALLATION

- A. Comply with manufacturer's instructions and recommendations for installation.
- B. Set units plumb, level, and true to line, without warp or rack of framing members, doors, or panels. Install components in proper alignment and relation to established lines and grades indicated. Provide proper support and anchor securely in place.
- C. Construction Tolerances: Install aluminum entrance and storefront to comply with the following tolerances:
 - 1. Variation from Plane: Do not exceed 1/8 inch in 12 feet of length or 1/4 inch in any total length.
 - 2. Offset from Alignment: The maximum offset from true alignment between two identical members abutting end to end in line shall not exceed 1/16 inch.
 - 3. Diagonal Measurements: The maximum difference in diagonal measurements shall not exceed 1/8 inch.
 - 4. Offset at Corners: The maximum out-of-plane offset of framing at corners shall not exceed 1/32 inch.
 - 5. Separate aluminum and other corrodible metal surfaces from sources of corrosion or electrolytic action at points of contact with other materials.
- D. Zinc or cadmium plate steel anchors and other unexposed fasteners after fabrication.
- E. Paint dissimilar metals where drainage from them passes over aluminum.
- F. Paint aluminum surfaces in contact with mortar, concrete or other masonry with alkali resistant coating.

- G. Paint wood and similar absorptive material in contact with aluminum and exposed to the elements or otherwise subject to wetting, with two coats of aluminum house paint. Seal joints between the materials with sealant.
- H. Drill and tap frames and doors and apply surface mounted hardware items. Comply with hardware manufacturer's instructions and template requirements. Use concealed fasteners wherever possible.
- I. Set sill members and other members in bed of sealant as indicated, or with joint fillers or gaskets as indicated to provide weathertight construction. Comply with requirements of Division 7 for sealants, fillers, and gaskets.
- J. Refer to "Glass and Glazing" Section of Division 8 for installation of glass and other panels indicated to be glazed into doors and framing, and not pre-glazed by manufacturer.

3.3 ADJUSTING

- A. Adjust operating hardware to function properly, for smooth operation without binding, and for weathertight closure.

3.4 CLEANING

- A. Clean the completed system, inside and out, promptly after installation, exercising care to avoid damage to coatings.
- B. Clean glass surfaces after installation, complying with requirements contained in **the "Glass and Glazing" Section** for cleaning and maintenance. Remove excess glazing and sealant compounds, dirt and other substances from aluminum surfaces.

3.5 PROTECTION

- A. Institute protective measures required throughout the remainder of the construction period to ensure that aluminum entrances and storefronts will be without damage or deterioration, other than normal weathering, at time of acceptance.

END OF SECTION 084113

SECTION 084232 - SLIDING AUTOMATIC ENTRANCES

PART 1 - GENERAL

1.1 SUMMARY

- A. Section includes exterior and interior, sliding, power-operated automatic entrances.
 - 1. Anodized Aluminum permanodic color finish “Dark Bronze” to match aluminum storefront color.

1.2 PREINSTALLATION MEETINGS

- A. Preinstallation Conference: Conduct conference at Project site.

1.3 SYSTEM PERFORMANCE REQUIREMENTS

- A. Structural Loading: Sliding Automatic Entrances shall be designed to resist loading as calculated by ASCE 7-10 based upon loading as specified on **drawing S1.01**.
- B. General: Provide sliding automatic entrances that comply with performance characteristics specified, as demonstrated by testing the manufacturer's corresponding stock assemblies according to test methods indicated:
- C. Air Infiltration Entrance Doors and Frames: Provide aluminum entrance doors with an air infiltration rate of not more than 0.5 CFM per lin. ft. of perimeter crack when tested in accordance with ASTM E 283 at an inward test pressure differential of 6.24 psf.
- D. Air Infiltration: Provide aluminum-framed systems with maximum air leakage through fixed glazing and framing areas of 0.06 cfm/sq. ft. of fixed wall area when tested according to ASTM E 283 at a minimum static-air-pressure difference of 6.24 lbf/sq. ft.
- E. Water Penetration under Static Pressure: Provide aluminum-framed systems that do not evidence water penetration through fixed glazing and framing areas when tested according to ASTM E 331 at a minimum static-air-pressure difference of 20 percent of positive wind-load design pressure, but not less than 30 lbf/sq. ft.

1.4 ACTION SUBMITTALS

- A. General: Submit the following in accordance with Conditions of the Contract and Division 01 Specification Sections:
 - 1. Provide calculations from the manufacturer supporting the system as designed meets the specified loading per ASCE 7-10 as indicated on drawing **S1.01**. If manufacturer cannot provide calculations, provide structural analysis calculations signed and sealed by a qualified structural engineer registered in the state of North Carolina. Analysis shall include sealed ASCE 7-10 calculations.

2. Product Data: For each type of product.

B. Shop Drawings: For automatic entrances.

1. Include plans, elevations, sections, hardware mounting heights, and attachment details.
2. Include diagrams for power, signal, and control wiring.
3. Indicate locations of activation and safety devices.
4. Include hardware schedule and indicate hardware types, functions, quantities, and locations.

C. Sample: For each exposed product and for each color and texture specified.

D. Delegated-Design Submittal: For automatic entrances.

1.5 INFORMATIONAL SUBMITTALS

A. Product certificates.

B. Product test reports.

C. Field quality-control reports.

D. Sample warranties.

1.6 CLOSEOUT SUBMITTALS

A. Operation and maintenance data.

1.7 QUALITY ASSURANCE

A. Installer Qualifications: Manufacturer's authorized representative who is trained and approved for installation and maintenance of units required for this Project.

B. Certified Inspector Qualifications: Certified by AAADM.

1.8 WARRANTY

A. Special Warranty: Manufacturer agrees to repair or replace components of automatic entrances that fail in materials or workmanship within specified warranty period.

1. Warranty Period: Two years from date of Final Acceptance.

B. Special Finish Warranty: Manufacturer agrees to repair or replace components on which finishes fail in materials or workmanship within specified warranty period.

1. Deterioration includes, but is not limited to, the following:

- a. Color fading more than 5 Hunter units when tested according to ASTM D 2244.
 - b. Chalking in excess of a No. 8 rating when tested according to ASTM D 4214.
 - c. Cracking, checking, peeling, or failure of paint to adhere to bare metal.
2. Warranty Period: Five years from date of Final Acceptance.

PART 2 - PRODUCTS

2.1 AUTOMATIC ENTRANCE ASSEMBLIES

- A. Electrical Components, Devices, and Accessories: Listed and labeled as defined in NFPA 70, by a qualified testing agency, and marked for intended location and application.
- B. Power-Operated Door Standard: BHMA A156.10.

2.2 PERFORMANCE REQUIREMENTS

- A. Delegated Design: Engage a qualified professional engineer, registered in the state of North Carolina to design automatic entrances.
- B. Wind Loads: As indicated on structural drawings, **S1.01**.
- C. Thermal Movements: Allow for thermal movements from ambient and surface temperature changes.
 1. Temperature Change: 120 deg F, ambient; 180 deg F, material surfaces.
- D. Air Infiltration: Maximum air leakage through fixed glazing and framing areas of 1.25 cfm/sq. ft. of fixed entrance-system area when tested according to ASTM E 283 at a minimum static-air-pressure difference of 1.57 lbf/sq. ft..

2.3 SLIDING AUTOMATIC ENTRANCES – EXTERIOR DOORS

- A. General: Provide manufacturer's standard automatic entrances including doors, sidelites, framing, headers, carrier assemblies, roller tracks, door operators, controls, and accessories required for a complete installation.
- B. Sliding Automatic Entrance:
 1. Basis-of-Design Product: Subject to compliance with requirements, provide Stanley Dura-Storm 3000 by Stanley Access Technologies, or comparable product by one of the following:
 - a. Biparting-Sliding Units:
 - 1) Besam Entrance Solutions; Subsidiary of ASSA ABLOY Entrance Systems.
 - 2) DORMA Automatics; Division of DORMA Group North America.
 - 3) Horton Automatics; a division of Overhead Door Corporation.

2. Configuration: Single and Biparting-sliding doors with transom and sidelights. See construction documents for individual units.
 - a. Traffic Pattern: Two way.
 - b. Emergency Breakaway Capability: Full Breakout. All door panels swing out.
 - c. Mounting: Between jambs.
3. Operator Features:
 - a. Power opening and closing.
 - b. Drive System: Chain or belt.
 - c. Adjustable opening and closing speeds.
 - d. Adjustable hold-open time between zero and 30 seconds.
 - e. Obstruction recycle.
 - f. On-off/hold-open switch to control electric power to operator, key operated.
 - g. Optional uninterrupted power supply.
4. Sliding-Door Carrier Assemblies and Overhead Roller Tracks: Carrier assembly that allows vertical adjustment; consisting of nylon- or delrin-covered, ball-bearing-center steel wheels operating on a continuous roller track, or ball-bearing-center steel wheels operating on a nylon- or delrin-covered, continuous roller track. Support doors from carrier assembly by cantilever and pivot assembly.
 - a. Rollers: Minimum of two ball-bearing roller wheels and two antirise rollers for each active leaf.
5. Sliding-Door Threshold: Threshold members and bottom-guide-track system with stainless-steel, ball-bearing-center roller wheels.
 - a. Configuration: Saddle-type threshold across door opening and recessed guide-track system at sidelites.
6. Controls: Activation and safety devices according to BHMA standards.
 - a. Activation Device: Motion sensor mounted on each side of door header to detect pedestrians in activating zone to activate door operator.
 - b. Safety Device: Presence sensor mounted on each side of door header and two photoelectric beams mounted in sidelite jambs on one side of the door to detect pedestrians in presence zone and to prevent door from closing.
 - c. Sidelite Safety Device: Presence sensor, mounted above each sidelite on side of door opening through which doors travel, to detect obstructions and to prevent door from opening.
7. Finish: Finish framing, door(s), and header with Architectural Class I (0.7 mils minimum), dark bronze permanodic color finishes.

2.4 SLIDING AUTOMATIC ENTRANCES – INTERIOR DOORS

- A. General: Provide manufacturer's standard automatic entrances including doors, sidelites, framing, headers, carrier assemblies, roller tracks, door operators, controls, and accessories required for a complete installation.
- B. Sliding Automatic Entrance:
1. Basis-of-Design Product: Subject to compliance with requirements, provide Stanley Dura-Glide 3000 by Stanley Access Technologies, or comparable product by one of the following:
 - a. Biparting-Sliding Units:
 - 1) Besam Entrance Solutions; Subsidiary of ASSA ABLOY Entrance Systems.
 - 2) DORMA Automatics; Division of DORMA Group North America.
 - 3) Horton Automatics; a division of Overhead Door Corporation.
 2. Configuration: Single and Biparting-sliding doors with transom and sidelights. See construction documents for individual units.
 - a. Traffic Pattern: Two way.
 - b. Emergency Breakaway Capability: Full Breakout. All door panels swing out.
 - c. Mounting: Between jambs.
 3. Operator Features:
 - a. Power opening and closing.
 - b. Drive System: Chain or belt.
 - c. Adjustable opening and closing speeds.
 - d. Adjustable hold-open time between zero and 30 seconds.
 - e. Obstruction recycle.
 - f. On-off/hold-open switch to control electric power to operator, key operated.
 - g. Optional uninterrupted power supply.
 4. Sliding-Door Carrier Assemblies and Overhead Roller Tracks: Carrier assembly that allows vertical adjustment; consisting of nylon- or delrin-covered, ball-bearing-center steel wheels operating on a continuous roller track, or ball-bearing-center steel wheels operating on a nylon- or delrin-covered, continuous roller track. Support doors from carrier assembly by cantilever and pivot assembly.
 - a. Rollers: Minimum of two ball-bearing roller wheels and two antirise rollers for each active leaf.
 5. Sliding-Door Threshold: Threshold members and bottom-guide-track system with stainless-steel, ball-bearing-center roller wheels.
 - a. Configuration: Saddle-type threshold across door opening and recessed guide-track system at sidelites.

6. Controls: Activation and safety devices according to BHMA standards.
 - a. Activation Device: Motion sensor mounted on each side of door header to detect pedestrians in activating zone to activate door operator.
 - b. Safety Device: Presence sensor mounted on each side of door header and two photoelectric beams mounted in sidelite jambs on one side of the door to detect pedestrians in presence zone and to prevent door from closing.
 - c. Sidelite Safety Device: Presence sensor, mounted above each sidelite on side of door opening through which doors travel, to detect obstructions and to prevent door from opening.
7. Finish: Finish framing, door(s), and header with Architectural Class I (0.7 mils minimum), dark bronze permanodic color finishes.

2.5 ENTRANCE COMPONENTS

- A. Framing Members: Extruded aluminum, minimum 0.125 inch thick and reinforced as required to support imposed loads.
 1. Nominal Size: As indicated on Drawings.
 2. Extruded Glazing Stops and Applied Trim: Minimum 0.062-inch wall thickness.
- B. Stile and Rail Doors: 1-3/4-inch- thick, glazed doors with minimum 0.125-inch-thick, extruded-aluminum tubular stile and rail members. Mechanically fasten corners with reinforcing brackets that are welded, or incorporate concealed tie-rods that span full length of top and bottom rails.
 1. Glazing Stops and Gaskets: Snap-on, extruded-aluminum stops and preformed gaskets.
 2. Stile Design: Medium stile, 3-1/2-inch nominal width.
 3. Rail Design: As indicated on Drawings.
 4. Muntin Bars: Horizontal tubular rail member for each door; match stile design and finish.
- C. Sidelite(s): 1-3/4-inch-deep sidelite(s) with minimum 0.125-inch- thick, extruded-aluminum tubular stile and rail members matching door design.
 1. Glazing Stops and Gaskets: Same materials and design as for stile and rail door.
 2. Glazing Stops and Gaskets: Snap-on, extruded-aluminum stops and preformed gaskets.
 3. Muntin Bars: Horizontal tubular rail members for each sidelite; match stile design.
- D. Headers: Fabricated from minimum 0.125-inch-thick extruded aluminum and extending full width of automatic entrance units to conceal door operators and controls. Provide hinged or removable access panels for service and adjustment of door operators and controls. Secure panels to prevent unauthorized access.
 1. Mounting: Concealed, with one side of header flush with framing.
- E. Signage: As required by cited BHMA standard.
 1. Application Process: Decals.

2.6 MATERIALS

- A. Aluminum: Alloy and temper recommended by manufacturer for type of use and finish indicated.
 - 1. Extrusions: ASTM B 221.
 - 2. Sheet: ASTM B 209.
- B. Steel Reinforcement: Reinforcement with corrosion-resistant primer complying with SSPC-PS Guide No. 12.00 applied immediately after surface preparation and pretreatment. Use surface preparation methods according to recommendations in SSPC-SP COM and prepare surfaces according to applicable SSPC standard.
- C. Stainless-Steel Bars: ASTM A 276 or ASTM A 666, Type 304.
- D. Stainless-Steel Tubing: ASTM A 554, Grade MT 304.
- E. Glazing: As specified in Section 088000 "Glazing."
- F. Sealants and Joint Fillers: As specified in Section 079200 "Joint Sealants."
- G. Nonmetallic, Shrinkage-Resistant Grout: Premixed, nonmetallic, noncorrosive, nonstaining grout; complying with ASTM C 1107/C 1107M; of consistency suitable for application.
- H. Bituminous Coating: Cold-applied asphalt emulsion complying with ASTM D 1187.
- I. Fasteners and Accessories: Corrosion-resistant, nonstaining, nonbleeding fasteners and accessories compatible with adjacent materials.

2.7 DOOR OPERATORS AND CONTROLS

- A. General: Provide operators and controls, which include activation and safety devices, according to BHMA standards, for condition of exposure, and for long-term, maintenance-free operation under normal traffic load for type of occupancy indicated.
- B. Door Operators: Provide door operators of size recommended by manufacturer for door size, weight, and movement.
 - 1. Door Operator Performance: Door operators shall open and close doors and maintain them in fully closed position when subjected to Project's design wind loads.
 - 2. Electromechanical Operators: Concealed, self-contained, overhead unit powered by fractional-horsepower, permanent-magnet dc motor; with closing speed controlled mechanically by gear train and dynamically by braking action of electric motor; with solid-state microprocessor controller; UL 325; and with manual operation with power off.
- C. Motion Sensors: Self-contained, K-band-frequency, microwave-scanner units; fully enclosed by its plastic housing; adjustable to provide detection-field sizes and functions required by BHMA A156.10.
 - 1. Provide capability for switching between bidirectional and unidirectional detection.
 - 2. For one-way traffic, sensor on egress side shall not be active when doors are fully closed.

- D. Presence Sensors: Self-contained, active-infrared scanner units; adjustable to provide detection-field sizes and functions required by BHMA A156.10. Sensors shall remain active at all times.
- E. Photoelectric Beams: Pulsed infrared, sender-receiver assembly for recessed mounting. Beams shall not be active when doors are fully closed.
- F. Electrical Interlocks: Unless units are equipped with self-protecting devices or circuits, provide electrical interlocks to prevent activation of operator when door is locked, latched, or bolted.

2.8 HARDWARE

- A. General: Provide units in sizes and types recommended by automatic entrance and hardware manufacturers for entrances and uses indicated. Finish exposed parts to match door finish unless otherwise indicated.
- B. Breakaway Device for Power-Operated Doors: Device that allows door to swing out in direction of egress to full 90 degrees from any operating position. Interrupt powered operation of door operator while in breakaway mode.
- C. Deadlocks: Deadbolt operated by exterior cylinder and interior thumb turn, with minimum 1-inch-long throw bolt; BHMA A156.5, Grade 1.
 - 1. Cylinders: As specified in Section 087100 "Door Hardware."
 - a. Keying: Integrate into building master key system.
 - 2. Deadbolts: Laminated-steel hook, mortise type, BHMA A156.5, Grade 1.
 - 3. Two-Point Locking for Stile and Rail Sliding Doors: Mechanism in stile of active door leaf that automatically extends second lockbolt into overhead carrier assembly.
- D. Weather Stripping: Replaceable components.
 - 1. Sliding Type: AAMA 701, made of wool, polypropylene, or nylon woven pile with nylon-fabric or aluminum-strip backing.

2.9 FABRICATION

- A. General: Factory fabricate automatic entrance components to designs, sizes, and thicknesses indicated and to comply with indicated standards.
- B. Framing: Provide automatic entrances as prefabricated assemblies. Complete fabrication, assembly, finishing, hardware application, and other work before shipment to Project site.
 - 1. Provide components with concealed fasteners and anchor and connection devices.
 - 2. Fabricate components with accurately fitted joints with ends coped or mitered to produce hairline joints free of burrs and distortion.
 - 3. Fabricate exterior components to drain condensation and water passing joints within system to the exterior.
 - 4. Provide anchorage and alignment brackets for concealed support of assembly from building structure.

- 5. Allow for thermal expansion of exterior units.
- C. Doors: Factory fabricated and assembled in profiles indicated. Reinforce as required to support imposed loads and for installing hardware.
- D. Door Operators: Factory fabricated and installed in headers, including adjusting and testing.
- E. Glazing: Fabricate framing with minimum glazing edge clearances for thickness and type of glazing indicated, according to GANA's "Glazing Manual."
- F. Hardware: Factory install hardware to greatest extent possible; remove only as required for final finishing operation and for delivery to and installation at Project site. Cut, drill, and tap for factory-installed hardware before applying finishes.
 - 1. Provide sliding-type weather stripping, mortised into door, at perimeter of doors.
- G. Controls:
 - 1. General: Factory install activation and safety devices in doors and headers as required by BHMA A156.10 for type of door and direction of travel.

2.10 ALUMINUM FINISHES

- A. Anodized Aluminum permanodic color finish "Dark Bronze" to match aluminum storefront color.

PART 3 - EXECUTION

3.1 INSTALLATION

- A. General: Install automatic entrances according to manufacturer's written instructions and cited BHMA standard for direction of pedestrian travel, including signage, controls, wiring, and connection to the building's power supply.
 - 1. Do not install damaged components. Fit frame joints to produce hairline joints free of burrs and distortion. Rigidly secure nonmovement joints. Seal joints watertight.
 - 2. Where aluminum will contact dissimilar metals, protect against galvanic action by painting contact surfaces with primer or by applying sealant or tape recommended by manufacturer for this purpose.
 - 3. Where aluminum will contact concrete or masonry, protect against corrosion by painting contact surfaces with bituminous coating.
- B. Entrances: Install automatic entrances plumb and true in alignment with established lines and grades without warp or rack of framing members and doors. Anchor securely in place.
 - 1. Install surface-mounted hardware using concealed fasteners to greatest extent possible.
 - 2. Set headers, carrier assemblies, tracks, operating brackets, and guides level and true to location with anchorage for permanent support.
 - 3. Install components to drain water passing joints, condensation occurring within framing members, and moisture migrating within system to exterior.

4. Level recesses for recessed thresholds using nonshrink grout.
- C. Door Operators: Connect door operators to electrical power distribution system.
- D. Access-Control Devices: Connect access-control devices to access-control system as specified in Section 281300 "Access Control."
- E. Controls: Install and adjust activation and safety devices according to manufacturer's written instructions and cited BHMA standard for direction of pedestrian travel. Connect control wiring according to Section 260519 "Low-Voltage Electrical Power Conductors and Cables."
- F. Glazing: Install glazing as specified in Section 088000 "Glazing".
- G. Sealants: Comply with requirements specified in Section 079200 "Joint Sealants" to provide weathertight installation.
 1. Set thresholds, bottom-guide-track system, framing members and flashings in full sealant bed.
 2. Seal perimeter of framing members with sealant.
- H. Signage: Apply signage on both sides of each door as required by cited BHMA standard for direction of pedestrian travel.
- I. Wiring within Automatic Entrance Enclosures: Bundle, lace, and train conductors to terminal points with no excess and without exceeding manufacturer's written limitations on bending radii. Provide and use lacing bars and distribution spools.

3.2 FIELD QUALITY CONTROL

- A. Certified Inspector: Engage a Certified Inspector to test and inspect components, assemblies, and installations, including connections.
- B. Perform the following tests and inspections with the assistance of a factory-authorized service representative:
 1. Test and inspect each automatic entrance, using AAADM inspection forms, to determine compliance of installed systems with applicable BHMA standards.
- C. Automatic entrances will be considered defective if they do not pass tests and inspections.
- D. Prepare test and inspection reports.

3.3 ADJUSTING

- A. Adjust hardware, moving parts, door operators, and controls to function smoothly, and lubricate as recommended by manufacturer; comply with requirements of applicable BHMA standards.
- B. Readjust door operators and controls after repeated operation of completed installation equivalent to three days' use by normal traffic (100 to 300 cycles).

3.4 DEMONSTRATION

- A. Engage a factory-authorized service representative to train Owner's maintenance personnel to adjust, operate, and maintain automatic entrances.

END OF SECTION 084232

SECTION 087100 - DOOR HARDWARE

PART 1 - GENERAL

1.1 RELATED DOCUMENTS

- A. Work under this section includes furnishing and the installation of finish hardware specified herein and noted on drawings for a complete and operational system, including any electrified door hardware components and low-speed auto operators.
- B. Drawings and general provisions of Contract, including General and Supplementary Conditions and Division 01 Specification sections, apply to work of this section.

1.2 DESCRIPTION OF WORK

- A. Definition: "Finish Hardware" includes items known commercially as finish / security hardware and systems which are required for swing, sliding and folding doors, except special types of unique and non-matching hardware specified in the same section as the door and door frame.
- B. Extent of finish / security hardware required is indicated on drawings and in Part 3: Hardware Sets. Provide items, articles, materials, operations and methods listed, mentioned or scheduled herein or on the drawings, in quantities as required to complete the project. Provide hardware that functions properly and compliant with required Codes: Fire/Life Safety/ADA. Prior to furnishing the hardware, advise the architect of items that will not operate properly, are improper for conditions, or will not remain permanently anchored.
- C. Types of finish hardware required include, but are not limited to, the following:
 - 1. Butt Hinges
 - 2. Continuous Hinges
 - 3. Lock cylinders and keys
 - 4. Lock and latch sets
 - 5. Exit devices
 - 6. Door Pulls
 - 7. Closers
 - 8. Door trim units
 - 9. Weatherstripping for exterior doors
 - 10. Protection plates
 - 11. Thresholds, Gaskets, and Door Bottoms
 - 12. Electrified Hardware
- D. References
 - 1. NFPA-80- as adopted - Standard for Fire Doors and Windows
 - 2. NFPA-101-as adopted - Life Safety Code
 - 3. NFPA - 70 - National Electric Code
 - 4. ADA - The Americans with Disabilities Act - Title III - Public Accommodations
 - 5. ANSI-A 117.1-American National Standards Institute - Accessible and Usable Buildings and Facilities
 - 6. ANSI-A156.5-American National Standards Institute - Auxiliary Locks and Associated Products
 - 7. NC Building Code as Adopted.
 - 8. Positive Pressure Testing UL10C & UBC7.2

9. UL - Underwriters Laboratories
10. WHI - Warnock Hersey International, Division of Intertek Testing Services
11. State, Local and Federal Codes, National Electrical Building Codes, including the Authority Having Jurisdiction.

1.3 QUALITY ASSURANCE

- A. Manufacturer: Obtain each type of hardware (ie., lock sets / security equipment) from a single manufacturer, although several may be indicated as offering products complying with requirements.
- B. Supplier: A recognized architectural finish hardware supplier, with warehousing facilities, who has been furnishing hardware and installation in the project's vicinity for a period of not less than 5 years. The supplier shall be, or shall employ, an Architectural Hardware Consultant (AHC) who is available, at reasonable times during the course of the work, for consultation about project's hardware requirements, to the Owner, Architect and the Contractor. The architectural hardware consultant (AHC) shall prepare all hardware and wiring diagrams. This Supplier is responsible for proper coordination of all finished hardware with related sections to insure compatibility of products. The Hardware Supplier shall attend all coordination meetings regarding hardware applications with related trades.
- C. Fire-Rated Openings: Provide hardware for fire-rated openings in compliance with NFPA Standard No. 80 and local building code requirements. Provide only hardware, which has been tested and listed by UL / WHI or FM for types and sizes of doors required and complies with requirements of door and door frame labels. Provide door seals to meet Positive Pressure Testing UL10C and UBC7 - 2 as required.
- D. Where emergency exit devices are required on fire-rated doors (with supplementary marking on doors' UL or FM labels indicating "Fire Door to be Equipped with Fire Exit Hardware") provide UL / WHI or FM label on exit devices indicating "Fire Exit Hardware".
- E. Thru bolt door closers at all doors and exit devices – except at FRP doors. The Hardware Supplier shall verify and coordinate proper blocking if provided from the door manufacturer for hardware attachment on doors.
- F. Unless otherwise specified, provide lever handle locksets ADA compliant.
- G. Pre-Installation Meeting: The GC /CM shall initiate and conduct a jobsite meeting with the hardware supplier and the Installer, and all related trades for mechanical and electrical hardware. This meeting shall convene at least one month prior to commencement of the related work, specifically, the electrical rough-in for coordination of electrified hardware applications. All approved shop drawings, wiring diagrams, and schedules shall be made available to all related trades as required for work to be performed. The Owner's representative shall attend all pre-install meetings. One month prior to the installation of the hardware, the hardware supplier shall, with the assistance of the manufacturer's representative, provide review/training to the Installers of the following products: closers, exit devices, locks, and electrified hardware.

1.4 SUBMITTALS

- A. Product Data: Submit manufacturer's technical product data for each item of hardware in accordance with Division-1 section "Submittals". Include whatever information may be necessary to show compliance with requirements, and include instructions for installation and for maintenance of operating parts and finish.

- B. Hardware Schedule: Submit copies of the schedule in accordance with Division 1 - "Submittals", General Requirements. Schedule shall be in vertical format, listing each door opening, including: handing, all hardware scheduled for the opening or otherwise required to allow for proper function of door openings as intended, and the finish of the hardware. At doors with door closers or door controls, include degree of door opening. If requested, all submittals (schedules, cut sheets, diagrams) shall be reviewed by the Owner's representative prior to ordering the material. Furnish wiring diagrams for all electrified hardware.
1. Final Hardware Schedule Content: Based on finish hardware indicated, organize hardware schedule into a vertical format with "hardware sets" indicating complete designations of every item required for each door or opening. Include the following information:
 - a. Type, style, function, size and finish of each hardware item.
 - b. Name and manufacturer of each item.
 - c. Fastenings and other pertinent information.
 - d. Maintain the same Set/Heading numbering from Part 3 of this section, or reference to the Spec Set number in the Heading.
 - e. Reference door numbers from the door/frame schedule in the plan set.
 - f. Explanation of all abbreviations, symbols, codes, etc., contained in schedule.
 - g. Mounting locations for hardware.
 - h. Door and frame sizes and materials.
 - i. Keying information as available.
 - j. One Heading/Set per page
 - k. Operational Description for all specified electrical hardware shall be included with each Heading/Set.
- C. Submittal Sequence: Submit hardware schedule and wiring diagrams according to the GC's established project schedule, particularly where acceptance of hardware schedule must precede fabrication of other work (e.g., hollow metal frames), and electrical rough-in, which is critical in the project construction schedule. Include with schedule the product data, catalog cuts, samples, templates, shop drawings of other work affected by finish hardware, and other information essential to the coordinated review of hardware schedule.
- D. Keying Schedule: Coordinate, and prepare as required, the keying schedule after meeting with the Owner to determine the Owner's instructions for keying.
- E. Samples if Requested: Prior to submittal of the final hardware schedule and prior to final ordering of finish hardware, submit any requested samples of type of exposed hardware unit, finished as required, and tagged with full description for coordination with schedule.
- F. Templates: Furnish hardware templates to each fabricator of doors, frames and other work to be factory-prepared for the installation of hardware. Upon request, check shop drawings of such other work, to confirm that adequate provisions are made for proper location, coordination and installation of hardware.
- G. Manufacturer's Catalog Cuts: Submit manufacturer's cut/catalog sheets on all hardware items and any required special mounting instructions with the hardware schedule.
- H. Wiring Diagrams: Provide complete wiring diagrams for each opening requiring electrified hardware. Provide an elevation drawing, with each electrified hardware set. Provide a point-to-point diagram prior to the delivery of hardware to job site and another copy to the Owner at time of job completion. All electrical components shall be listed by opening in the hardware submittals. Include an operational description with each diagram.

- I. Operational Descriptions: Provide a complete operational description of the specified electrified hardware components for each opening, and include the description under the hardware set/heading in the hardware submittal. Operational descriptions shall detail how each electrified component functions within the opening, incorporating all conditions of ingress and egress. Review these descriptions with all related trades at the Pre-Install meetings.
- J. Elevation Drawings: Provide elevation drawings of electronic hardware and systems identifying locations of the system components with respect to their placement in the door opening. Include the number of wires, with the gauge included, needed at the specific locations. Provide a copy with each hardware schedule submitted for approval. Supply another copy to the Owner upon project completion. Include an operational description with each drawing.

1.5 PRODUCT HANDLING

- A. Tag each item or package separately, with identification related to final hardware schedule, and include basic installation instructions with each item or package.
- B. Inventory hardware jointly with the General Contractor, representatives of hardware supplier / hardware installer until each is satisfied that count is correct.
- C. Deliver individually packaged hardware items at the proper times to the proper locations (**shop or project site**) for installation.
- D. The General Contractor shall provide secure lock-up for hardware and security equipment delivered to the project, but not yet installed. Control handling and installation of hardware items, which are not immediately replaceable, so that completion of the work will not be delayed by hardware losses, both before and after installation.

1.6 SEQUENCING AND SCHEDULING

- A. Deliver all finish hardware to the job site in a timely manner so not to delay progress of other trades.

1.7 WARRANTY

- A. Door closers shall include a thirty (30) year manufacturers' warranty against defects in materials and workmanship.
- B. Exit Devices shall include a three (3) year warranty.
- C. Hinges: Life of Building.
- D. Electrified Hardware shall include a one (1) year warranty.
- E. Other Hardware shall include a three (3) year warranty.

PART 2 - PRODUCTS

2.1 SCHEDULED HARDWARE

- A. Requirements for design, grade, function, finish, size and other distinctive qualities of each type of finish hardware are indicated in the Finish Hardware Data Sheet and Hardware Schedule at the end of this section. Products are identified by using hardware designation numbers of the following:

B. Manufacturers:

	Hardware Item:	Specified Manufacturer	Designation
1.	Butt Hinges:	McKinney	MC
2.	Continuous Hinges	Ives	MC
3.	Locksets:	Corbin Russwin	CR
4.	Cylinders/Cores	Corbin Russwin	CR
5.	Silencers:	Rockwood	RO
6.	Stops:	Rockwood	RO
7.	Overhead Stops	Rixson	RX
8.	Closers:	LCN	LCN
9.	Thresholds:	Pemko	PE
10.	Gasket/Door Bottoms:	Pemko	PE
11.	Kickplates:	Rockwood	RO
12.	Pull/Push Plates:	Rockwood	RO
13.	Exit Devices:	Von Duprin	VD
14.	Flush Bolts:	Rockwood	RO
15.	Automatic Flush Bolts:	Rockwood	RO
16.	Electrohydraulic Door Operators	Norton Rixson	NO
17.	Miscellaneous Hardware:		

- C. Provide products as hereafter specified. Substitutions other than those manufacturers listed, must be approved, in writing, via addenda, prior to bid. Procedure for substitutions shall be as outlined in Division 1. No substitutions will be considered after award of contract.

2.2 MATERIALS AND FABRICATION

A. General:

1. Hand of Door: Drawings show direction of slide, swing or hand of each door leaf. Furnish each item of hardware for proper installation and operation of door movement as shown.
2. Coordinate door pulls with cylinder lock location to confirm pulls do not interfere with access to lock. Provide offset pulls if required.
3. Manufacturer's Name Plate: Do not use manufacturer's products which have manufacturer's name or trade name displayed in a visible location (omit removable nameplates), except in conjunction with required UL labels and as otherwise acceptable to Architect.
4. Manufacturer's identification will be permitted on rim of lock cylinders only.
5. Finishes:
 - a. 626/652 for all finished metal hardware items except as 630 is otherwise indicated. Door closers to be powder coated to match 652/626. Exit devices shall be US26D with stainless steel touchbars.
6. Fasteners: Provide hardware manufactured to conform to published templates, generally prepared for machine screw installation. Do not provide hardware, which has been prepared for self-tapping sheet metal screws, except, as specifically indicated.
7. Furnish screws for installation, with each hardware item. Provide Phillips flat-head screws except as otherwise indicated. Finish exposed (exposed under any condition) screws to match hardware finish or, if exposed in surfaces of other work, to match finish of such other work as closely as possible, including "prepared for paint" in surfaces to receive painted finish.
8. Provide concealed fasteners for hardware units which are exposed when door is closed,

except to extent no standard units of type specified are available with concealed fasteners. Use thru-bolts for closer and exit devices. Coordinate wood door blocking at all wood doors and all fire-rated wood doors. Provide sleeves for each thru-bolt or use sex screw fasteners.

9. Tools and Maintenance Instructions for Maintenance: Furnish a complete set of specialized tools and maintenance instructions as needed for Owner's continued adjustment, maintenance, and removal and replacement of finish hardware.

2.3 HINGES AND BUTTS

- A. Templates: Except for hinges and pivots to be installed entirely (both leaves) into wood doors and frames, provide only template-produced units.
- B. Screws: Furnish Phillips flat-head or machine screws for installation of units, except furnish Phillips flat-head or wood screws for installation of units into wood. Finish screw heads to match surface of hinges or pivots.
- C. Hinge Pins: Except as otherwise indicated, provide hinge pins as follows:
 1. Steel Hinges: Steel pins.
 2. Non-ferrous Hinges: Stainless steel pins.
 3. Exterior Doors: Non-removable pins.
 4. Out-swing doors with locking device: Non-removable pins.
 5. Interior Doors: Non-rising pins.
 6. Tips: Flat button and matching plug, finished to match leaves.
 7. Number of hinges: Provide number of hinges indicated but not less than 3 hinges for door leaf for doors 90" or less in height and one additional hinge for each 30" of additional height.
8. **Owner Preferred:**
 - a. **McKinney: TB2714/TB2314/T4B3786/T4B3386**
9. Acceptable Manufacturers:
 - b. Ives: 5BB1/5BB1HW
 - c. Stanley: FBB179/199/168/191
- D. Continuous Hinges: Provide concealed, non-handed, full height hinges with interlocking cover and symmetrically template hole pattern made from extruded aluminum. Finish shall be BHMA 628. Field modifications for cutting shall be permitted up to 6" from the bottom.
 1. **Owner Preferred**
 - a. **Ives: 224HD.**
 2. Acceptable Manufacturers:
 - b. Select: SL21HD
 - c. McKinney: CFM

2.4 CYLINDERS AND KEYING

- A. General: The Hardware Supplier shall furnish the keyed permanent cores and keys for the project. All locks/cylinders shall be furnished with keyed temporary construction cores. The construction

cores shall utilize a color-coded construction cores system which is not part of the Owner's existing permanent key system. The Hardware Supplier shall be responsible for furnishing/invoicing the GC for the construction cores. The General Contractor, under the supervision of the Owner, shall install permanent cores and return the construction cores to the Hardware Supplier for credit to the GC. The Owner shall assume no responsibility for construction cores, and the construction cores shall not be part of the Owner's material list from the GC. All permanent keyed cores shall be furnished as Corbin Russwin LFIC. Provide permanent keys and cores stamped with the applicable key mark for identifications. These visual key control marks or codes shall not include the actual key cuts: VKC. (Visual Key Control)

- B. Coastal Carolina Community College's existing key system is a Corbin Russwin restricted (patented) grandmaster system which shall be utilized for all project keying requirements. Equip locks and cylinders with Corbin Russwin factory-keyed cores as specified. All cylinder housings shall accept Corbin Russwin keyed LFIC permanent cores. The Hardware Supplier shall confirm all keying and core requirements with the Owner's representative prior to ordering the cores. **The College's master system is based on Corbin 6 pin. The current keyway in use is the CO91.**
- C. Provide permanent keys and cores stamped with the applicable key mark for identifications. These visual key control marks or codes shall not include the actual key cuts: VKC. All cylinders/locksets shall be furnished with temporary construction keyed cores for the construction period of the project. Furnish five (5) Construction Keys and one (1) control key for the General Contractor's use during project construction. Furnish five (5) each Grandmaster keys. Furnish five (5) each Master keys (per master group). Furnish a total of three (3) change keys per cylinder or keyed alike group. Actual cut keys to be determined by the school district. All keys shall be stamped with key symbols and "Do Not Duplicate".
- D. DO NOT provide any permanent control keys.
- E. Provide one (1) each bitting list to the Owner by registered mail.
- F. **Owner Preferred:**
 - 1. **Corbin Russwin**

2.5 MORTISE LOCKS

- A. Locksets shall be as specified: Mortise lockset shall be Series 1000, Grade 1 Operational and Security, UL Listed for 3-hour fire door. Strikes: Provide manufacturer's standard wrought box strike for each latch or lock bolt, with ANSI curved lip extended to protect frame, finished to match hardware set. Where specified, provide a replaceable breakaway spindle mechanism residing inside the lock chassis. The lock case shall be full wrapped heavy gauge steel with all metal zinc dichromate plated working parts. Lock case shall be universal function type and allow for field reversible handing without opening the lock case. Lever rotation shall be in both directions for ease of use, and allow for independent lever rotation. All locks except Corbin Russwin shall be furnished as "less cylinder". Add Corbin Russwin cylinders with keyed permanent cores.
- B. Lock Throw: Provide solid stainless steel 1-1/2" deadbolt with 1" minimum throw. Comply with UL requirements for throw of bolts and latch bolts on rated fire openings.
- C. Provide 3/4" minimum throw on latch bolts.
- D. Lever Design: 'Lustra' lever as manufactured by Corbin-Russwin or equal.

D. Owner Preferred:

1. **Corbin-Russwin ML2000 x LWA**

E. Acceptable Manufacturers:

1. Schlage L9000 x 03A
2. Yale 8800 x CRR

2.6 CYLINDRICAL LOCKS

- A. Locksets shall be as specified: ANSI A156.2 Series 4000, Grade 1, UL Listed for 3-hour fire door.

B. Owner Preferred:

1. **Corbin-Russwin CL3300 Series.**

C. Acceptable Manufacturers: Must match existing key system.

1. Schlage ND Series.
2. Yale AU 5400 Series with LFIC

2.7 PULLS/ PUSH PLATES

- A. Exposed Fasteners: Provide manufacturer's standard exposed fasteners for installation; through-bolted for matched pairs, but not for single units. Furnish type and size as specified in Hardware Sets.

B. Acceptable Manufacturers:

1. Ives
2. Burns
3. Trimco
4. Rockwood

2.8 CLOSERS AND DOOR CONTROL DEVICES

- A. Size of Units: Except as otherwise specifically indicated, comply with the manufacturer's recommendations for size of door control unit, depending upon size of door, exposure to weather and anticipated frequency of use.

- B. Closers: All door closers shall be of one manufacturer to provide for proper installation and servicing after installation. All closers shall use high strength cast iron cylinders, forged main arms, and one-piece forged steel pistons. All closers shall be inspected after installation by a factory representative to ensure proper adjustment and operation. A report shall be filed with the architect after said visit has been made. Closer shall carry a manufacturer's minimum 20-year warranty for hydraulic units and 2-year warranty for electrical and/or handicap power assist door closers against manufacturing defects and workmanship. PRV [pressure relief valves] are not acceptable.

- C. Parallel Arm Closers: Shall incorporate one piece solid forged steel arms steel stud shoulder bolts, shall be incorporated in regular arms, hold open arms, arms with stop built in, arms with hold

open and stop built in. All other closers to have forged steel main arms for strength, and durability. Unless otherwise specified, mount all closers parallel arm.

- D. Built-In Stops: Where closers with built-in positive stops are used, the stops shall be of one piece cast malleable iron material with built in springs. Where required, the hold-open assembly handle for these stops shall rotate on ball bearings.
- E. All door closers shall pass UL10C positive pressure fire test.
- F. Provide closers with adjustable spring power. Size closers to ensure exterior and fire rated doors will consistently close and latch. Size all other door closer to allow for reduced opening force not to exceed 5 lbs.
- G. Hydraulic Fluid: All closers, with the exception of interior electronic closers, shall utilize temperature stable fluid capable of withstanding temperature ranges of 120 degrees F. to -30F. without requiring seasonal adjustment of closer speed to properly close the door. Fluid shall be nonflammable.
- H. All closers shall have a powder coat finish on closer body, arm, cover and adapter plate. Furnish special rust inhibiting pretreat coating, as specified, for closer body, arm, cover and plates before the powder coat finish.
- I. All door closers shall have full covers and separate adjusting valves for sweep, latch and back-check. Provide all drop plates, shoe supports, templates, etc. to properly mount closers according to manufacturers' recommendations.
- J. **Owner Preferred:**
 - 1. **LCN 4040XP/4040XP**
- K. Acceptable Manufacturers:
 - 1. Corbin-Russwin DC8200
 - 2. Sargent 281
- L. Through bolts shall be used for attachment of closers at all doors.

2.9 EXIT DEVICES

- A. General: All devices shall be of one manufacturer to provide for proper installation and servicing. Devices shall be furnished non-handed and capable of direct field conversion for all available trim functions. All devices shall carry a minimum three-year warranty against manufacturing defects and workmanship. All devices shall be push-through touch pad design as specified. No exposed touch bar fasteners, no exposed cavities when operated.
- B. Furnish all touch-pad type devices with stainless steel touch bars.
- C. Furnish all touch-pad type exit devices with deadlocking latch bolts. Latchbolts shall be moly-coated or stainless steel.
- D. Furnish all touch-pad exit devices with flush end caps. End caps shall be flush with device housing with no raised edges.

- E. All removable mullions shall be furnished with key function for removal. Furnish stabilizers similar to Von Duprin 154 with all removable mullions.
- F. Outside Trim: Shall be heavy duty type and fastened by means of concealed welded lugs and thru-bolts from the inside. Trim shall be forged brass with a minimum average thickness on the escutcheon of .130. Plate with trim shall be brass with minimum average thickness of .090 and have forged pulls. Where outside trim is specified, furnish trim that thru-bolts directly to the exit device center case.
- G. Furnish cylinders with all lockable exit devices.
- H. Furnish required filler plates and shim kits for flush mounting of exit devices on all doors requiring same. Exit devices to be mounted on full-glass doors, shall not have exposed fasteners on the mechanism case.
- I. Exit Device Dogging: Except on fire-rated doors, wherever closers are provided on doors equipped with exit devices, equip the units with keyed dogging device to hold the push bar down and the latch bolt in the open position, or as Less Dogging (LD) as specified.
- J. Owner Preferred:**
 - 1. Von Duprin 99 Series**
- K. Acceptable Manufacturers:
 - 1. Precision 2100 series
 - 2. Sargent 80 series

2.10 ELECTROHYDRAULIC DOOR OPERATORS

- A. Electrohydraulic Door Operators (High Traffic): Provide ANSI/BHMA A156.19 Certified Products Directory (CPD) listed low energy operators that meet ANSI/BHMA A156.4 requirements and are UL listed for use on fire rated doors and UL10C certified that comply with requirements for the Americans with Disabilities Act (ADA). Operators shall be verified by GreenCircle to offer energy savings of 19% when compared to similar products to accommodate openings up 250 pounds and 48" wide.
 - 1. Provide operators with features as follows:
 - a. Non-handed with push and pull side mounting.
 - b. Operates as mechanical surface closer during close cycles, when door is opened manually or if power is off.
 - c. Activation by push button, hands-free or radio frequency devices.
 - d. On board electronics to collect usage and cycle count data to facilitate preventative maintenance/diagnostics.
 - e. Two-year limited warranty.
 - f. Wi-Fi interface.
 - g. Mounting backplate to simplify and speed up installation.

2. Operators shall have the following functionality:
 - a. Adjustable Hold Open: Amount of time a door will stay in the full open position after an activation.
 - b. Blow Open for Smoke Ventilation: Door opens when signal is received from alarm system allowing air or smoke to flow through opening. Door will stay open until signal from alarm system is stopped.
 - c. Infinite Hold Open: Door will hold open at set position until power is turned off.
 - d. Obstruction Detection: Door closes if it hits an obstruction while opening; door will reverse to open position if it hits an obstruction while closing. Door will stop once it hits an obstruction and will rest against the obstruction until removed.
 - e. Open Delay: Delays operator opening for locking hardware.
 - f. Overload Safety Shut-Off: After two minutes of receiving a door activation signal, inverter times out and door closes to prevent motor/inverter damage.
 - g. Presence Detector Input: Input for external sensor to detect presence at door open or close position only.
 - h. Push & Go: As the door is manually opened, the operator "senses" movement and opens door to the full-open position.
 - i. Selector Mode Switch: Off disables the signal inputs unless Blow Open is activated, on activates the signal inputs, hold open activates the unit (unless Blow Closed is activated) to the hold open position.
 - j. Vestibule Delay: When the wall switch is pressed, first door in vestibule will open. Second door will open once vestibule door delay has expired. Delay is adjustable.
3. Manufacturers:
 - a. Gyrotech Nabco - GT500 Series.
 - b. LCN (LC) - 4630/4640 Series.
 - c. Norton Rixson (NO) - 6000 Series.

2.11 DOOR TRIM UNITS

- A. Fasteners: Provide manufacturer's standard exposed fasteners for door trim units (kick plates, edge trim, viewers, knockers, mail drops and similar units); either machine screws or self-tapping screws.
- B. Fabricate edge trim of stainless steel, not more than 1/2" nor less than 1/16" smaller in length than door dimension.
- C. Fabricate protection plates (armor, kick or mop) not more than 2" less than door width on stop side and not more than 1" less than door width on pull side, x the height indicated.
- D. Metal Plates: Stainless steel, .050" (U.S. 18 ga), bevel 3 edges: top and both sides.
- E. Acceptable Manufacturers:
 1. Ives
 2. Trimco
 3. Burns

4. Rockwood.

2.12 FLUSH BOLTS AND SURFACE BOLTS

- A. Provide products conforming to ANSI/BHMA A156.3 and A156.16, Grade 1.
 1. Flush bolts to be furnished with top rod of sufficient length to allow bolt retraction device location approximately six feet from the floor.
 2. Furnish dust proof strikes for bottom bolts.
 3. Surface bolts to be minimum 8” in length and U.L. listed for labeled fire doors and U.L. listed for windstorm components where applicable.
 4. Provide related accessories (mounting brackets, strikes, coordinators, etc.) as required for appropriate installation and operation.
 5. Manufacturers:
 - a. Door Controls International (DC).
 - b. Ives (IV).
 - c. Rockwood (RO).
 - d. Trimco (TC).

2.13 GASKETS, DOOR BOTTOMS

- A. General: Except as otherwise indicated, provide continuous weatherstripping at each edge of every exterior door leaf, except where stated the door manufacturer will provide the weatherstripping.. Provide type, sizes and profiles shown or scheduled. Provide non-corrosive fasteners as recommended by manufacturer for application indicated. All gaskets for fire label doors shall comply the door manufacturers label approvals. Fire-label wood doors shall be furnished as “Category A” type with the intumescent seal, integral to the door construction.

2.14 THRESHOLDS

- A. General: Except as otherwise indicated provide standard aluminum threshold unit of type, size and profile as shown or scheduled.
- B. Provide thresholds that are 1” wider than depth of frame.
- C. Provide gasketed threshold for all exterior doors.
- D. The hardware supplier shall verify all sill conditions and finish floor conditions and coordinate proper threshold as required to insure a smooth transition between threshold and the interior floor.
- E. Acceptable Manufacturers:
 1. National Guard
 2. Zero
 3. Reese
 4. Pemko

2.15 DOOR SILENCERS

- A. All hollow metal frames shall have gray resilient type silencers. Quantity (3) on single doors and quantity (2) on pair of doors.

2.16 OVERHEAD STOPS

- A. Furnish type specified in hardware sets. Through-bolts shall be used for attachment of overhead holders.
- B. Acceptable Manufacturers:
 - 1. Glynn Johnson: 90 series
 - 2. Sargent: 590 series.
 - 3. Rixson: 9 series

2.17 WALL STOPS

- A. Furnish a stop or holder for all doors. Furnish floor stops only where specifically indicated. Where wall stops are not applicable, furnish overhead stops. Holder shall not be furnished at fire-rated doors.
- B. Acceptable Manufacturers:
 - 1. Ives: WS406/407CCV
 - 2. Trimco: 1270WXCP
 - 3. DCI: 3211
 - 4. Rockwood: 406/409.

2.18 ARCHITECTURAL SEALS

- A. General: Thresholds, weatherstripping, and gasket seals to be of type and design as specified below or in the Hardware Sets. Provide continuous weatherstrip gasketing on exterior doors and provide smoke, light, or sound gasketing on interior doors where indicated. At exterior applications provide non-corrosive fasteners and elsewhere where indicated.
- B. Smoke Labeled Gasketing: Assemblies complying with NFPA 105 that are listed and labeled by a testing and inspecting agency acceptable to authorities having jurisdiction, for smoke control ratings indicated, based on testing according to UL 1784.
 - 1. Provide smoke labeled perimeter gasketing at all smoke labeled openings.
- C. Fire Labeled Gasketing: Assemblies complying with NFPA 80 that are listed and labeled by a testing and inspecting agency acceptable to authorities having jurisdiction, for fire ratings indicated, based on testing according to UL-10C.

1. Provide intumescent seals as indicated to meet UL10C Standard for Positive Pressure Fire Tests of Door Assemblies, and NFPA 252, Standard Methods of Fire Tests of Door Assemblies.
- D. Sound-Rated Gasketing: Assemblies that are listed and labeled by a testing and inspecting agency, for sound ratings indicated.
- E. Replaceable Seal Strips: Provide only those units where resilient or flexible seal strips are easily replaceable and readily available from stocks maintained by manufacturer.
- F. Manufacturers:
 1. National Guard Products (NG).
 2. Pemko (PE).
 3. Reese Enterprises, Inc. (RE).

PART 3 - EXECUTION

3.1 INSTALLATION

- A. Mount hardware units at heights indicated in "Recommended Locations for Builders Hardware for Standard Steel Doors and Frames" by the Door and Hardware Institute, except as specifically indicated or required to comply with governing regulations, and except as may be otherwise directed by Architect.
- B. Install each hardware item in compliance with the manufacturer's instructions and recommendations. Wherever cutting and fitting is required to install hardware onto or into surfaces, which are later to be painted or finished in another way, coordinate removal, storage and reinstallation or application of surface protections with finishing work specified in the Division 09 sections. Do not install surface-mounted items until finishes have been completed on the substrate.
- C. Set units level, plumb and true to line and location. Adjust and reinforce the attachment substrate as necessary for proper installation and operation.
- D. Drill and countersink units, which are not factory-prepared for anchorage fasteners. Space fasteners and anchors in accordance with industry standards.
- E. Set thresholds for exterior doors in full bed of butyl-rubber or polyisobutylene mastic sealant.
- F. Adjust and reinforce attachment substrate for proper installation and operation:
 1. Gaskets: Install jamb-applied gaskets before closers, overhead stops, rim strikes, etc.
- G. Locate floor stops not more than 4 inches from the wall.
- H. Verify actual locations of wiring connections before electrified door hardware is installed.
- I. Examine doors and frames with the hardware installer for compliance with requirements for installation tolerances, labeled fire door assembly, wall and floor construction, and other conditions affecting door performance.

- J. Existing door/frame conditions: The GC and all related trades shall review the existing conditions prior to ordering and installing any new hardware. Notify the architect of any exceptions. All existing doors scheduled to be re-worked and re-used shall be reviewed with the Finish Hardware Submittal and templates before the doors are prepped for the new hardware and re-hung in the door opening.
- K. The Hardware Installer shall be responsible for installation of all mechanical and electromechanical hardware items specified in the Hardware Sets, at the end of the section, in accordance with the manufacturer's technical installation guidance, and in addition to all applicable code requirements. Electromechanical hardware items include: electrified hinges, power transfers, network locksets, network exit trim, electrified panic devices.
- L. The Division 26 Electrical sub-contractor shall make all wiring connections from the electrified hardware to the power source wiring. The Electrical sub-contractor shall install and connect all power supplies to the electrified hardware items. The Electrical sub-contractor shall provide and install all (120VAC) power source wiring as required for the electrified locking and access control hardware, equipment, accessories, and power supplies.

3.2 ADJUST AND CLEAN

- A. Adjust and check each operating item of hardware and each door, to ensure proper operation or function of every unit. Replace units, which cannot be adjusted to operate freely and smoothly as intended for the application made.
- B. Clean adjacent surfaces soiled by hardware installation.
- C. Final Adjustment: Wherever hardware installation is made more than one month prior to acceptance or occupancy of a space or area, return to the work during the week prior to acceptance or occupancy, and make final check and adjustment of all hardware items in such space or area. Clean operating items as necessary to restore proper function and finish of hardware and doors. Adjust door control devices to compensate for final operation of heating and ventilating equipment.
- D. Instruct Owner's Personnel in proper adjustment and maintenance of hardware and hardware finishes, during the final adjustment of hardware.
- E. Continued Maintenance Service: Approximately six months after the acceptance of hardware in each area, the Installer, accompanied by the representative[s] of the Finish Hardware manufacturer[s], shall return to the project and re-adjust every item of hardware to restore proper function of doors and hardware. Consult with and instruct Owner's personnel in recommended additions to the maintenance procedures. Replace hardware items, which have deteriorated or failed due to faulty design, materials or installation of hardware units. Prepare a written report of any current or predictable problems (of substantial nature) in the performance of the hardware and furnish copy to Owners Agent / Representative.
- F. Manufacturer's Abbreviations:

1. MK - McKinney

2. PE - Pemko

3. RF - Rixson
4. AD - Adams Rite
5. RU - Corbin Russwin
6. VD - Von Duprin
7. RO - Rockwood
8. LC - LCN Closers
9. SA – Sargent
10. NO - Norton
11. SU - Securiton
12. OT – Other

Hardware Sets

Set: 1.0

Doors: 123

Each to have:

3	Hinge, Full Mortise	TA2714	US26D	MK
1	Storeroom Lock	ML2057 LWA CL6	626	RU
1	Interchangeable Core	CR8000 CKC2	626	RU
1	Temp Core	CR8000 CT6B	626	RU
1	Wall Stop	409	US32D	RO
3	Silencer	608-RKW		RO

Set:2.0

Doors: 102, 127

Each to have:

1	Storeroom Lock	ML2057 LWA CL6	626	RU
1	Interchangeable Core	CR8000 CKC2	626	RU
3	Temp Core	CR8000 CT6B	626	RU

Set: 3.0

Doors: 121

Each to have:

3	Hinge, Full Mortise	TA2714	US26D	MK
1	Storeroom Lock	ML2057 LWA CL6	626	RU
1	Interchangeable Core	CR8000 CKC2	626	RU
1	Temp Core	CR8000 CT6B	626	RU
1	Surface Closer	4040XP .RWPA	.689	LC
1	Kick Plate	K1050 8" High	US32D	RO
1	Wall Stop	409	US32D	RO
3	Silencer	608-RKW		RO

Set: 4.0

Doors: 105

Each to have:

6	Hinge, Full Mortise	TA2714	US26D	MK
2	Flush Bolt	555	US26D	RO
1	Dust Proof Strike	570	US26D	RO
1	Storeroom Lock	ML2057 LWA CL6	626	RU

1	Interchangeable Core	CR8000 CKC2	626	RU
1	Temp Core	CR8000 CT6B	626	RU
2	Kick Plate	K1050 8" High	US32D	RO
2	Wall Stop	409	US32D	RO
1	Astragal	S771C		PE
6	Silencer	608-RKW		RO
Set: 5.0				
Doors: 103, 104, 106, 107, 116, 117, 118				
Each to have:				
3	Hinge, Full Mortise	TA2714	US26D	MK
1	Office Lock	ML2051 LWA CL6	626	RU
1	Interchangeable Core	CR8000 CKC2	626	RU
1	Temp Core	CR8000 CT6B	626	RU
1	Wall Stop	409	US32D	RO
3	Silencer	608-RKW		RO
Set: 6.0				
Doors: 129, 130, 136, 137, 138				
Each to have:				
3	Hinge, Full Mortise	TA2714	US26D	MK
1	Passage Latch	ML2010 LWA	626	RU
1	Interchangeable Core	CR8000 CKC2	626	RU
1	Temp Core	CR8000 CT6B	626	RU
1	Surface Closer	4040XP RWPA	689	LC
1	Wall Stop	409	US32D	RO
3	Silencer	608-RKW		RO
Set: 7.0				
Doors: 110				
Each to have:				
3	Hinge, Full Mortise	TA2714	US26D	MK
1	Passage Latch	ML2010 LWA	626	RU
1	Interchangeable Core	CR8000 CKC2	626	RU
1	Temp Core	CR8000 CT6B	626	RU
1	Surface Closer	4040XP RWPA	689	LC
1	Wall Stop	409	US32D	RO
3	Silencer	608-RKW		RO

<u>Set: 8.0</u>			
Doors: 119, 120			
Each to have:			
3	Hinge, Full Mortise	TA2714	US26D MK
1	Pull Plate	BF 111x70C	US32D RO
1	Push Plate	70C-RKW	US32D RO
1	Automatic Opener	6000 Series	689 NO
1	Kick Plate	K1050 8" High	US32D RO
1	Wall Stop	409	US32D RO
1	Gasketing	S442BL	PE
2	Door Switch	505	NO
1	Power Supply	AQD (size as req.) x PDB (as req.)	SU
1	Wiring Diagram	Elevation and Point to Point as Specified	OT
<u>Set: 9.0</u>			
Doors: 124,139			
Each to have:			
3	Hinge, Full Mortise	TA2714	US26D MK
1	Deadbolt	DL4117 M34 CL6	626 RU
1	Interchangeable Core	CR8000 CKC2	626 RU
1	Temp Core	CR8000 CT6B	626 RU
1	Pull Plate	BF 111x70C	US32D RO
1	Push Plate	70C-RKW	US32D RO
1	Surface Closer	4040XP .RWPA	.689 LC
1	Mop Plate	K1050 4" High	US32D RO
1	Kick Plate	K1050 8" High	US32D RO
1	Wall Stop	409	US32D RO
1	Gasketing	S442BL	PE
3	Silencer	608 RKW	RO
<u>Set: 10.0</u>			
Doors: 100B, 113A, 125A, 134A			
1	All Hardware	By Door Manufacturer	OT
1	Wiring Diagram	Elevation and Point to Point as Specified	OT

<u>Set: 11.0</u>				
Doors: 100A, 113B, 115, 125B, 134B				
1	Interchangeable Core	CR8000 CKC2	626	RU
1	Temp Core	CR8000 CT6B	626	RU
1	Mortise Cylinder	As required	US32D	SA
1	Balance of Hardware	By Door Manufacturer		OT
1	Wiring Diagram	Elevation and Point to Point as Specified		OT
<u>Set: 12.0</u>				
NOTE: Hardware Set 12.0 is NOT IN CONTRACT. Hardware is provided and installed by Owner.				
Doors: 101, 126, 206, 224				
1	Fire Rated Rim Exit, Classroom Lever Trim	F .996L-R/V .03	.626	VD
1	Balance of Hardware	Reuse existing hardware		OT
<u>Set: 13.0</u>				
Doors: 122				
2	Hinge, Full Mortise	TA2714	US26D	MK
1	Hinge, Full Mortise	TA2714 QC_	US26D	MK
1	Access Control Mort Lock	ML20606 x SN200-SEC LSA CL6	626	RU
1	Interchangeable Core	CR8000 CKC2	626	RU
1	Temp Core	CR8000 CT6B	626	RU
1	Surface Closer	4040XP .RWPA	.689	LC
1	Kick Plate	K1050 10" High	US32D	RO
1	Wall Stop	409	US32D	RO
3	Silencer	608-RKW		RO
1	ElectroLynx Harness	QC-C**** x Length Required		MK
1	ElectroLynx Harness	QC-C1500P		MK
1	Power Supply	AQD (size as req.) x PDB (as req.)		SU
1	Wiring Diagram	Elevation and Point to Point as Specified		OT

END OF SECTION 087100

SECTION 088000 - GLAZING

PART 1 - GENERAL

1.1 SUMMARY

- A. This Section includes glazing for the following products and applications:
1. Windows.
 2. Doors.
 3. Glazed entrances.
 4. Storefront framing.

1.2 PERFORMANCE REQUIREMENTS

- A. General: Provide glazing systems capable of withstanding normal thermal movement and wind and impact loads (where applicable) without failure, including loss or glass breakage attributable to the following: defective manufacture, fabrication, and installation; failure of sealants or gaskets to remain watertight and airtight; deterioration of glazing materials; or other defects in construction.
- B. Glass Design: Glass thicknesses indicated are minimums and are for detailing only. Confirm glass thicknesses by analyzing Project loads and in-service conditions. Provide glass lites for various size openings in nominal thicknesses indicated, but not less than thicknesses and in strengths (annealed or heat treated) required to meet or exceed the following criteria:
1. Glass Thicknesses: Select minimum glass thicknesses to comply with ASTM E 1300, according to the following requirements:
 - a. Design Wind Loads: Glazing shall be designed to resist loading as calculated by ASCE 7-10 based upon wind loading delineated in the structural drawings, **S1.01**.
 - b. Probability of breakage value specified in subparagraph below for sloped glazing is based on a design factor of 5.0.
 - c. Minimum Glass Thickness for Exterior Lites: Not less than 6 mm.
 - d. Thickness of Tinted and Heat-Absorbing Glass: Provide the same thickness for each tint color indicated throughout Project.
 2. Sloped Glazing: For glass surfaces sloped more than 15 degrees from vertical, design glass to resist each of the following combinations of loads:
 - a. Outward design wind pressure minus the weight of the glass. Base design on glass type factors for short-duration load.
 - b. Inward design wind pressure plus the weight of the glass plus half of the design snow load. Base design on glass type factors for short-duration load.
 - c. Half of the inward design wind pressure plus the weight of the glass plus the design snow load. Base design on glass type factors for long-duration load.
- C. Thermal Movements: Provide glazing that allows for thermal movements resulting from a maximum change (range) of 120 deg F, in ambient and surface temperatures, respectively,

acting on glass framing members and glazing components. Base engineering calculation on surface temperatures of materials due to both solar heat gain and nighttime-sky heat loss.

- D. Thermal and Optical Performance Properties: Provide glass with performance properties specified based on manufacturer's published test data, as determined according to procedures indicated below:
1. For monolithic-glass lites, properties are based on units with lites 6 mm thick.
 2. For insulating-glass units, properties are based on units with lites 6 mm thick and a nominal 1/2-inch- wide interspace.
 3. Center-of-Glass U-Values: NFRC 100 methodology using LBL-35298 WINDOW 4.1 computer program, expressed as Btu/ sq. ft. x h x deg F.
 4. Center-of-Glass Solar Heat Gain Coefficient: NFRC 200 methodology using LBL-35298 WINDOW 4.1 computer program.
 5. Solar Optical Properties: NFRC 300.

1.3 SUBMITTALS

- A. Product Data: For each glass product and glazing material indicated.
- B. Samples: 12-inch- square, for each type of glass product indicated.
- C. Glazing Schedule: Use same designations indicated on Drawings.
- D. Sealant compatibility and adhesion test reports.

1.4 QUALITY ASSURANCE

- A. Sealant Compatibility and Adhesion Testing: Use sealant manufacturer's standard test methods to determine whether priming and other specific joint preparation techniques are required to obtain rapid, optimum adhesion of joint sealants to joint substrates.
- B. Glazing Publications: Comply with recommendations of the following, unless more stringent requirements are indicated.
 1. GANA Publications: "Glazing Manual."
- C. Insulating-Glass Certification Program: Permanently marked with certification label of Insulation Glass Certification Council. .

1.5 WARRANTY

- A. Special Warranty: Manufacturer's standard form, made out to Owner and signed by manufacturer, in which manufacturer agrees to furnish replacements for units that deteriorate from normal use by developing defects attributable to the manufacturing process, f.o.b. the nearest shipping point to Project site, within warranty period.
 1. Coated Glass:

- a. Defects: Peeling, cracking, and other indications of degradation of metallic coating.
 - b. Warranty Period: 10 years from date of Final Acceptance.
2. Insulating Glass:
- a. Deterioration: Failure of hermetic seal resulting in obstruction of vision by dust, moisture, or film on interior surfaces of glass.
 - b. Warranty Period: 10 years from date of Final Acceptance.

PART 2 - PRODUCTS

2.1 MANUFACTURERS

- A. In other articles including schedules where subparagraph titles below introduce lists, the following requirements apply for product selection:
 - 1. Manufacturers: Subject to compliance with requirements, provide products by the manufacturers specified.

2.2 GLASS MATERIALS

- A. Insulating-Glass Units: Preassembled units consisting of sealed lites of glass separated by a dehydrated interspace, and complying with ASTM E 774 for Class CBA units and with requirements specified in this Article and in the Insulating-Glass Schedule at the end of Part 3.
 - 1. Provide Kind HS (heat-strengthened) float glass in place of annealed glass where needed to resist thermal stresses induced by differential shading of individual glass lites and to comply with glass design requirements specified in "Performance Requirements" Article.
 - a. Provide Kind FT (fully tempered) as required by the North Carolina State Building Code for Safety Glazing.
 - b. Provide Kind FT (fully tempered) as required by the North Carolina State Building Code as required to meet wind loading requirements.
 - 2. Overall Unit Thickness and Thickness of Each Lite: Dimensions indicated in the Insulating-Glass Schedule at the end of Part 3 are nominal and the overall thicknesses of units are measured perpendicularly from outer surfaces of glass lites at unit's edge.
 - 3. Sealing System: Dual seal with manufacturers standard primary and secondary sealants.
 - 4. Spacer: Manufacturer's standard.
 - 5. Corner Construction: Manufacturer's standard.
 - 6. Overall Unit Thickness and Thickness of Each Lite: 25 and 6 mm.
 - 7. Interspace Content: Argon.

2.3 GLAZING SEALANTS

- A. General: Provide products of type indicated, complying with the following requirements:
 - 1. Compatibility: Select glazing sealants that are compatible with one another and with other materials they will contact, including glass products, seals of insulating-glass units, and glazing channel substrates, under conditions of service and application, as demonstrated by sealant manufacturer based on testing and field experience.
 - 2. Colors of Exposed Sealants: As selected by the Architect.

2.4 GLAZING GASKETS

- A. Compression Gaskets: Molded or extruded gaskets of type and material indicated below and of profile and hardness required to maintain watertight seal:
 - 1. EPDM dense compression gaskets complying with ASTM C 846.

2.5 MISCELLANEOUS GLAZING MATERIALS

- A. General: Provide products of material, size, and shape complying with referenced glazing standard, requirements of manufacturers of glass and other glazing materials for application indicated, and with a proven record of compatibility with surfaces contacted in installation.
- B. Cleaners, Primers, and Sealers: Types recommended by sealant or gasket manufacturer.
- C. Setting Blocks: Elastomeric material with a Shore A durometer hardness of 85, plus or minus 5.
- D. Spacers: Elastomeric blocks or continuous extrusions with a Shore A durometer hardness required by glass manufacturer to maintain glass lites in place for installation indicated.
- E. Edge Blocks: Elastomeric material of hardness needed to limit glass lateral movement (side walking).
- F. Cylindrical Glazing Sealant Backing: ASTM C 1330, Type O (open-cell material), of size and density to control glazing sealant depth and otherwise produce optimum glazing sealant performance.
- G. Perimeter Insulation for Fire-Resistive Glazing: Identical to product used in test assembly to obtain fire-resistance rating.

2.6 FABRICATION OF GLASS AND OTHER GLAZING PRODUCTS

- A. Fabricate glass and other glazing products in sizes required to glaze openings indicated for Project, with edge and face clearances, edge and surface conditions, and bite complying with written instructions of product manufacturer and referenced glazing standard, to comply with system performance requirements.

PART 3 - EXECUTION

3.1 GLAZING, GENERAL

- A. Comply with combined written instructions of manufacturers of glass, sealants, gaskets, and other glazing materials, unless more stringent requirements are indicated, including those in referenced glazing publications.
 - 1. Clean glazing channels and other framing members receiving glass immediately before glazing. Remove coatings not firmly bonded to substrates.
 - 2. Protect glass edges from damage during handling and installation. Remove glass with edge damage or other imperfections that, when installed, could weaken glass and impair performance and appearance from Project site and legally dispose of off Project site.
 - 3. Apply primers to joint surfaces where required for adhesion of sealants, as determined by sealant compatibility and adhesion testing.
 - 4. Do not exceed edge pressures stipulated by glass manufacturers for installing glass lites.
 - 5. Provide spacers for glass lites where the length plus width is larger than 50 inches unless gaskets and glazing tapes are used that have demonstrated ability to maintain required face clearances.
- B. Protection:
 - 1. Protect exterior glass from damage immediately after installation by attaching crossed streamers to framing held away from glass. Do not apply markers to glass surface.
 - 2. Protect glass from contact with contaminating substances resulting from construction operations, including weld splatter.
- C. Remove and replace glass that is broken, chipped, cracked, abraded, or damaged, including natural causes, accidents, and vandalism, during construction period.

3.2 GLASS SCHEDULE

- A. General:
 - 1. All exterior glazing and insulated units shall be provided by single source and same manufacturer.
- B. Manufacturers:
 - 1. Guardian Industries.
 - 2. Pilkington.
 - 3. PPG Industries, Inc.
- C. Uncoated Tempered Glass (G-1)
 - 1. ¼" Kind FT fully tempered, clear.
- D. Tempered Insulated Glass (G-2) (Interior Vestibule Walls):
 - 1. Insulating-Glass Units:

2. Basis of Design: Solarban 60(2) Starphire +Starphire by PPG. Subject to compliance with requirements provide comparable high performance insulating units by one of the following:
 - a. Viracon.
 - b. Guardian Industries.
3. Performance Characteristics:
 - a. Overall Unit Thickness and Thickness of Each Lite: 6.0 mm.
 - b. Interspace Content: Air.
 - c. Airspace: 12 mm.
4. Outdoor Lite: Solarban 60(2) Starphire + Starphire
 - a. Kind FT (fully tempered).
5. Indoor Lite: Class 1 (clear) float glass.
 - a. Kind FT (fully tempered).
6. Visible Light Transmittance: 74 percent minimum.
7. Outdoor Visible Reflectance: 11 percent maximum.
8. Winter Nighttime U-Factor: 0.29 maximum.
9. Solar Heat Gain Coefficient: 0.41 maximum.
10. Shading Coefficient : .48 maximum.

E. Tempered Insulated Glass (G-3)

1. Solar Control Low-E Insulating-Glass Units:
2. Basis of Design: Solarbronze 70XL by PPG. Subject to compliance with requirements provide comparable high performance insulating units by one of the following:
 - a. Pilkington
 - b. Guardian Industries
3. Performance Characteristics:
 - a. Overall Unit Thickness and Thickness of Each Lite: 1”.
 - b. Interspace Content: Air.
 - c. Airspace: 12mm.
4. Outdoor Lite: Solarban 70 XL (2) Solarbronze.
 - a. Kind FT (fully tempered).
5. Indoor Lite: Class 1 (clear) float glass.
 - a. Kind FT (fully tempered).
6. Visible Light Transmittance: 40 percent minimum
7. Ultra-Violet transmittance: 3 percent
8. Outdoor Visible Reflectance: 7 percent maximum.
9. Winter Nighttime U-Factor: 0.28 maximum.
10. Summer Daytime U-Factor: 0.26 maximum.
11. Solar Heat Gain Coefficient: 0.21 maximum.
12. Shading Coefficient : .25 maximum

END OF SECTION 088000

SECTION 092216 - NON-STRUCTURAL METAL FRAMING

PART 1 - GENERAL

1.1 RELATED DOCUMENTS

- A. Drawings and general provisions of the Contract, including General and Supplementary Conditions and Division 01 Specification Sections, apply to this Section.

1.2 SUMMARY

- A. This Section includes non-load-bearing steel framing members for the following applications:
 1. Interior framing systems (e.g., supports for partition walls, framed soffits, furring, etc.).
 2. Interior suspension systems (e.g., supports for ceilings, suspended soffits, etc.).

1.3 SUBMITTALS

- A. Product Data: For each type of product indicated.

1.4 QUALITY ASSURANCE

- A. Fire-Test-Response Characteristics: For fire-resistance-rated assemblies that incorporate non-load-bearing steel framing, provide materials and construction identical to those tested in assembly indicated according to ASTM E 119 by an independent testing agency. Products used in the assembly shall carry a classification label from a testing laboratory acceptable to authority having jurisdiction.
- B. STC-Rated Assemblies: For STC-rated assemblies, provide materials and construction identical to those tested in assembly indicated according to ASTM E 90 and classified according to ASTM E 413 by an independent testing agency.

PART 2 - PRODUCTS

2.1 NON-LOAD-BEARING STEEL FRAMING, GENERAL

- A. Framing Members, General: Comply with ASTM C 754 for conditions indicated.
 1. Steel Sheet Components Meeting requirements of ASTM C645-08; C-channel, roll-formed from hot-dipped galvanized steel; complying with ASTM A1003 and ASTM A653 G40 or equivalent corrosion resistant coating.
 2. Structural performance of steel stud assemblies: American Iron and Steel Institute AISI “North American Specification for the Design of Cold Formed Steel Structural Members”, and by authorities having jurisdiction whichever is more restrictive.

3. Minimum steel stud framing size, height and material thickness requirements: Unless otherwise indicated, design and provide steel framing to comply with SSMA (Steel Stud Manufacturers Association) limitations for height and gauge for wall heights indicated.
 - a. Deflection criteria: $L/240$.
 - b. Assemblies for wall exceeding height limitations for single studs shall be spliced and braced back to structure to provide an overall deflection limit of $L/240$ in all cases.

B. Metal Stud And Track

1. Subject to compliance with requirements, employ manufacturer's load values and tables to determine standard stud gauges and sizes for loading and partition height.
 - a. At Contractor's Option: provide all dimpled steel framing in 20 to 25 gauge-equivalent depending on loading values.
 - b. Dimpled steel framing is used in fire rated partitions to be installed in accordance with UL V450 or UL V438 or UL U419.
2. 20 gauge or heavier studs shall be used adjacent to all interior doorframes, and at walls to receive ceramic tile finish.
3. Protective Coating (exterior walls): Coating with equivalent corrosion resistance of ASTM A 653/A 653M and ASTM A 1003/A 1003M hot-dip galvanized, unless otherwise indicated.

2.2 SUSPENSION SYSTEM COMPONENTS

- A. Tie Wire: ASTM A 641/A 641M, Class 1 zinc coating, soft temper, 0.0625-inch- diameter wire, or double strand of 0.0475-inch- diameter wire.
- B. Hanger Attachments to Concrete:
 1. Anchors: Fabricated from corrosion-resistant materials with holes or loops for attaching wire hangers and capable of sustaining, without failure, a load equal to 5 times that imposed by construction as determined by testing according to ASTM E 488 by an independent testing agency.
 - a. Type: Postinstalled, expansion anchor.
 2. Powder-Actuated Fasteners: Suitable for application indicated, fabricated from corrosion-resistant materials with clips or other devices for attaching hangers of type indicated, and capable of sustaining, without failure, a load equal to 10 times that imposed by construction as determined by testing according to ASTM E 1190 by an independent testing agency.
- C. Wire Hangers: ASTM A 641/A 641M, Class 1 zinc coating, soft temper, 0.162-inch diameter.
- D. Carrying Channels: Cold-formed, commercial-steel sheet with a base-metal thickness of 0.0538 inch and minimum 1/2-inch- wide flanges.
 1. Depth: 1/2 inch.

E. Furring Channels (Furring Members):

1. Cold-Formed Channels: 0.0538-inch bare-steel thickness, with minimum 1/2-inch- wide flanges, 3/4 inch deep.
2. Steel Studs: ASTM C 645.
 - a. Minimum Base-Metal Thickness: 0.0296 inch.
 - b. Depth: As indicated on Drawings, or where not indicated, minimum 4-inch nominal.
3. Hat-Shaped, Rigid Furring Channels: ASTM C 645, 7/8 inch deep.
 - a. Minimum Base Metal Thickness: 0.0296 inch.
4. Resilient Furring Channels: 1/2-inch- deep members designed to reduce sound transmission.
 - a. Configuration: Asymmetrical.

F. Grid Suspension System for Ceilings: ASTM C 645, direct-hung system composed of main beams and cross-furring members that interlock.

1. Available Products: Subject to compliance with requirements, products that may be incorporated into the Work include, but are not limited to, the following:
 - a. Armstrong World Industries, Inc.; Drywall Grid Systems.
 - b. Chicago Metallic Corporation; 640-C and Fire Front 650-C Drywall Furring System.
 - c. USG Corporation; Drywall Suspension System.

2.3 STEEL FRAMING FOR FRAMED ASSEMBLIES

A. Steel Studs and Runners: ASTM C 645.

1. Minimum Base-Metal Thickness: 0.0296 inch or members that can show certified third party testing in accordance with ICC – ES – AC86 that meets ASTM C645-08 Section 9.2.
 - a. Minimum thickness for spliced / braced assemblies: 0.0538 inch. (1.37mm).
2. Depth: As indicated on Drawings.
3. Deflection criteria: L/360.

B. Slip-Type Head Joints: Where indicated, provide one of the following:

1. Double-Runner System: ASTM C 645 top runners, inside runner with 2-inch- deep flanges in thickness not less than indicated for studs and fastened to studs, and outer runner sized to friction fit inside runner.
2. Deflection Track: Steel sheet top runner manufactured to prevent cracking of finishes applied to interior partition framing resulting from deflection of structure above; in thickness not less than indicated for studs and in width to accommodate depth of studs.

- a. Available Products: Subject to compliance with requirements, products that may be incorporated into the Work include, but are not limited to, the following:
 - 1) Steel Network Inc. (The); VertiClip SLD Series.
 - 2) Superior Metal Trim; Superior Flex Track System (SFT).
 - 3) Dietrich Metal Framing, SLP-TRK® Slotted Deflection Track by Brady Innovations.

- C. Firestop Tracks: Top runner manufactured to allow partition heads to expand and contract with movement of the structure while maintaining continuity of fire-resistance-rated assembly indicated; in thickness not less than indicated for studs and in width to accommodate depth of studs.
 - 1. Available Products: Subject to compliance with requirements, products that may be incorporated into the Work include, but are not limited to, the following:
 - a. Fire Trak Corp.; Fire Trak attached to studs with Fire Trak Slip Clip.
 - b. Metal-Lite, Inc.; The System.
 - c. Dietrich Metal Framing, SLP-TRK® Slotted Deflection Track by Brady Innovations.

- D. Cold-Formed Channel Bridging: 0.0538-inch bare-steel thickness, with minimum 1/2-inch- wide flanges.
 - 1. U-Channel Assembly: Depth: 1-1/2 inches.
 - a. Clip Angle: Not less than 1-1/2 inches by 1-1/2 inches, 0.068-inch-thick, galvanized steel.

- E. Hat-Shaped, Rigid Furring Channels: ASTM C 645.
 - 1. Minimum Base Metal Thickness: 0.0296 inch.
 - 2. Depth: 7/8 inch

- F. Resilient Furring Channels: 1/2-inch-deep, steel sheet members designed to reduce sound transmission.
 - 1. Configuration: Asymmetrical.

- G. (Non-acoustical assemblies) Z-Shaped Furring: With slotted or nonslotted web, face flange of 1-1/4 inches, wall attachment flange of 7/8 inch, minimum bare-metal thickness of 0.0179 inch, and depth required to fit insulation thickness indicated.

- H. Flat Strap and Backing Plate: Sheet for blocking and bracing in length and width indicated.
 - 1. Subject to compliance with requirements, provide fire treated wood backing.
 - 2. Galvanized Sheet Steel.

- I. Radius Framing: Steel sheet runner for non-load-bearing curves, bends, variable radii and arches.

2.4 AUXILIARY MATERIALS

- A. General: Provide auxiliary materials that comply with referenced installation standards.
 - 1. Fasteners for Metal Framing: Of type, material, size, corrosion resistance, holding power, and other properties required to fasten steel members to substrates.
- B. Isolation Strip at Exterior Walls: Provide the following:
 - 1. Foam Gasket: Adhesive-backed, closed-cell vinyl foam strips that allow fastener penetration without foam displacement, 1/8-inch thick, in width to suit steel stud size.

PART 3 - EXECUTION

3.1 EXAMINATION

- A. Examine areas and substrates, with Installer present, and including welded hollow-metal frames, cast-in anchors, and structural framing, for compliance with requirements and other conditions affecting performance.
 - 1. Proceed with installation only after unsatisfactory conditions have been corrected.

3.2 PREPARATION

- A. Suspended Assemblies: Coordinate installation of suspension systems with installation of overhead structure to ensure that inserts and other provisions for anchorages to building structure have been installed to receive hangers at spacing required to support the Work and that hangers will develop their full strength.
 - 1. Furnish concrete inserts and other devices indicated to other trades for installation in advance of time needed for coordination and construction.
- B. Coordination with Sprayed Fire-Resistive Materials:
 - 1. Before sprayed fire-resistive materials are applied, attach offset anchor plates or ceiling runners (tracks) to surfaces indicated to receive sprayed fire-resistive materials. Where offset anchor plates are required, provide continuous plates fastened to building structure not more than 24 inches o.c.
 - 2. After sprayed fire-resistive materials are applied, remove them only to extent necessary for installation of non-load-bearing steel framing. Do not reduce thickness of fire-resistive materials below that required for fire-resistance ratings indicated. Protect adjacent fire-resistive materials from damage.

3.3 INSTALLATION, GENERAL

- A. Installation Standard: ASTM C 754, except comply with framing sizes and spacing indicated.

1. Gypsum Board Assemblies: Also comply with requirements in ASTM C 840 that apply to framing installation.
- B. Install supplementary framing, and blocking to support fixtures, equipment services, heavy trim, grab bars, toilet accessories, furnishings, or similar construction.
- C. Install bracing at terminations in assemblies.
- D. Do not bridge building control and expansion joints with non-load-bearing steel framing members. Frame both sides of joints independently.

3.4 INSTALLING SUSPENSION SYSTEMS

- A. Install suspension system components in sizes and spacings indicated on Drawings, but not less than those required by referenced installation standards for assembly types and other assembly components indicated.
- B. Isolate suspension systems from building structure where they abut or are penetrated by building structure to prevent transfer of loading imposed by structural movement.
- C. Suspend hangers from building structure as follows:
 1. Install hangers plumb and free from contact with insulation or other objects within ceiling plenum that are not part of supporting structural or suspension system.
 - a. Splay hangers only where required to miss obstructions and offset resulting horizontal forces by bracing, countersplaying, or other equally effective means.
 2. Where width of ducts and other construction within ceiling plenum produces hanger spacings that interfere with locations of hangers required to support standard suspension system members, install supplemental suspension members and hangers in the form of trapezes or equivalent devices.
 3. Wire Hangers: Secure by looping and wire tying, either directly to structures or to inserts, eye screws, or other devices and fasteners that are secure and appropriate for substrate, and in a manner that will not cause hangers to deteriorate or otherwise fail.
 4. Do not attach hangers to steel roof deck.
 5. Do not attach hangers to permanent metal forms. Furnish cast-in-place hanger inserts that extend through forms.
 6. Do not attach hangers to rolled-in hanger tabs of composite steel floor deck.
 7. Do not connect or suspend steel framing from ducts, pipes, or conduit.
- D. Fire-Resistance-Rated Assemblies: Wire tie furring channels to supports.
- E. Seismic Bracing: Sway-brace suspension systems with hangers used for support.
- F. Grid Suspension Systems: Attach perimeter wall track or angle where grid suspension systems meet vertical surfaces. Mechanically join main beam and cross-furring members to each other and butt-cut to fit into wall track.

- G. Installation Tolerances: Install suspension systems that are level to within 1/8 inch in 12 feet measured lengthwise on each member that will receive finishes and transversely between parallel members that will receive finishes.

3.5 INSTALLING FRAMED ASSEMBLIES

- A. Where studs are installed directly against exterior masonry walls or dissimilar metals at exterior walls, install isolation strip between studs and exterior wall.
- B. Install studs so flanges within framing system point in same direction.
 - 1. Space studs as follows:
 - a. Single-Layer Application: 16 inches o.c., unless otherwise indicated.
 - b. Multilayer Application: 24 inches o.c., unless otherwise indicated.
 - c. Tile backing panels: 16 inches o.c., unless otherwise indicated.
- C. Install tracks (runners) at floors and overhead supports. Extend framing full height to structural supports or substrates above suspended ceilings, except where partitions are indicated to terminate at suspended ceilings. Continue framing around ducts penetrating partitions above ceiling.
 - 1. Slip-Type Head Joints: Where framing extends to overhead structural supports, install to produce joints at tops of framing systems that prevent axial loading of finished assemblies.
 - 2. Door Openings: Screw vertical studs at jambs to jamb anchor clips on doorframes; install runner track section (for cripple studs) at head and secure to jamb studs.
 - a. Install two studs at each jamb, unless otherwise indicated.
 - b. Install cripple studs at head adjacent to each jamb stud, with a minimum 1/2-inch clearance from jamb stud to allow for installation of control joint in finished assembly.
 - c. Extend jamb studs through suspended ceilings and attach to underside of overhead structure.
 - 3. Other Framed Openings: Frame openings other than door openings the same as required for door openings, unless otherwise indicated. Install framing below sills of openings to match framing required above door heads.
 - 4. Fire-Resistance-Rated Partitions: Install framing to comply with fire-resistance-rated assembly indicated and support closures and to make partitions continuous from floor to underside of solid structure.
 - a. Firestop Track: Where indicated, install to maintain continuity of fire-resistance-rated assembly indicated.
 - 5. Sound-Rated Partitions: Install framing to comply with sound-rated assembly indicated.
 - 6. Curved Partitions:
 - a. Bend track to uniform curve and locate straight lengths so they are tangent to arcs.
 - b. Begin and end each arc with a stud, and space intermediate studs equally along arcs. On straight lengths of not less than 2 studs at ends of arcs, place studs 6 inches o.c.

- D. Direct Furring:
 - 1. Attach to concrete or masonry with stub nails, screws designed for masonry attachment, or powder-driven fasteners spaced 24 inches o.c.
- E. Installation Tolerance: Install each framing member so fastening surfaces vary, not more than 1/8 inch from the plane formed by faces of adjacent framing.

END OF SECTION 092216

SECTION 092513 – ACRYLIC PLASTER SOFFIT FINISH

PART 1 - GENERAL

1.1 SUMMARY

A. Section Includes:

1. Textured finish system for exterior gypsum board soffit and ceiling surfaces.

1.2 PREINSTALLATION MEETINGS

- ##### A. Preinstallation Conference: Conduct conference at Project site.

1.3 ACTION SUBMITTALS

- ##### A. Product Data: For each component, trim, and accessory, including water-resistive coatings.
- ##### B. Samples: For each exposed product and for each color and texture specified.

1.4 INFORMATIONAL SUBMITTALS

- ##### A. Manufacturer certificates.
- ##### B. Product certificates.
- ##### C. Product test reports.
- ##### D. Manufacturer's standard warranty
- ##### E. Applicator's industry training credentials

1.5 CLOSEOUT SUBMITTALS

- ##### A. Maintenance data.

1.6 QUALITY ASSURANCE

- ##### A. Installer's Qualifications: The contractor shall be qualified to perform the work specified by reason of experience. Contractor shall have at least 5 years of experience in commercial textured finish application, and shall have completed at least 3 projects of similar size and complexity.
- ##### B. Mock-ups: The contractor shall install a mock-up of the system for evaluation and approval by the Architect.

PART 2 - PRODUCTS

2.1 STUCCO FINISH SYSTEM [APSF]

- A. Basis-of-Design Product Direct Applied Exterior Finish System: Subject to compliance with requirements, provide StoQuik Gold Finish System or comparable product by one of the following:
 - 1. Dryvit Systems, Inc.
 - 2. Parex USA, Inc.
- B. Textured Finishes
 - 1. High performance decorative and protective acrylic-based textured wall finish with integral color.
 - a. Color as selected by Architect from manufacturer's full range.
- C. Primer
 - 1. Acrylic-based sanded primer.
- D. Base Coat
 - 1. One component polymer modified portland cement high build base coat
- E. Surface Reinforcement
 - 1. Mesh – nominal 4.5 oz/yd² (153 g/m²) glass fiber reinforcing mesh treated for compatibility with manufacturer's materials

2.2 EXTERIOR GYPSUM SHEATHING

- A. Basis of Design Product: Subject to compliance with requirements, provide DensGlass Sheathing by Georgia-Pacific or comparable product by one of the following:
 - 1. National Gypsum
 - 2. USG
- B. Trim Accessories: Type as designated or required to suit conditions indicated and to comply manufacturer's written instructions; manufactured from UV-stabilized PVC; and complying with ASTM D 1784, manufacturer's standard cell class for use intended, and ASTM C 1063.

PART 3 - EXECUTION

3.1 INSTALLATION

- A. General Surface Preparation
 - 1. Gypsum soffit board must be installed in conformance with the applicable building code and manufacturer's written installation instructions. Gypsum soffit board surface must be clean, dry, and free of surface contamination. Gypsum soffit board surface shall not have

planar irregularities in excess of 1/16 inch (1.6 mm) and shall be free of voids, cracks, and other surface defects.

B. Mixing

1. Mix products in accordance with published literature. Refer to applicable Product Bulletins for specific information on use, handling, application, precautions, and limitations of specific products.

C. Application

1. Install corrosion proof termination accessories with perforated flanges for keying of the base coat at junctures with penetrations such as soffit vents, electrical fixtures, and with abutting walls and columns. Install corrosion proof control joints with perforated flanges for keying of the base coat at intervals as required by the gypsum soffit board manufacturer. Refer to manufacturer's guide details.
2. Install nominal 1/8 inch (3 mm) base coat by trowel to the soffit/ceiling board surface. Work horizontally or vertically in strips of 40 inches (1016 mm), and immediately embed the mesh into the wet base coat by troweling from the center to the edge of the mesh. Overlap mesh not less than 2-1/2 inches (64 mm) at mesh seams and feather at seams. Double wrap all inside and outside corners with minimum 8-inch (203 mm) overlap in each direction (except where corner bead is used at outside corners lap mesh over perforated flange of accessory). Avoid wrinkles in the mesh. The mesh must be fully embedded so that no mesh color shows through the base coat when it is dry. Re-skim with additional base coat if mesh color is visible. Overlap perforated flanges of accessories with the base coat/reinforcing mesh application. Do not install base coat and mesh onto solid (unperforated) portions of accessories.
3. When the base coat application is dry apply the primer by brush or roller to the entire base coat surface.
4. When the primer application is dry apply the textured finish by trowel. Apply finish in a continuous application, and work to a wet edge. Float the finish to achieve the desired texture.

3.2 Protection

1. Provide protection of installed materials from water infiltration into or behind them during and after construction.
2. Provide protection of installed materials from dust, dirt, precipitation, freezing and continuous high humidity until they are fully dry.
3. Seal penetrations through the finished surface with backer rod and sealant or other appropriate means.

END OF SECTION 092513

SECTION 092900 - GYPSUM BOARD

PART 1 - GENERAL

1.1 RELATED DOCUMENTS

- A. Drawings and general provisions of the Contract, including General and Supplementary Conditions and Division 01 Specification Sections, apply to this Section.

1.2 SUMMARY

- A. This Section includes the following:
 - 1. Interior gypsum board for standard applications.
 - 2. Aluminum trim and expansion units.

1.3 SUBMITTALS

- A. Product Data: For each type of product indicated.
- B. Samples: For the following products:
 - 1. Trim Accessories: Full-size Sample in 12-inch- long length for each trim accessory indicated.

1.4 QUALITY ASSURANCE

- A. Fire-Resistance-Rated Assemblies: For fire-resistance-rated assemblies, provide materials and construction identical to those tested in assembly indicated according to ASTM E 119 by an independent testing agency.
- B. STC-Rated Assemblies: For STC-rated assemblies, provide materials and construction identical to those tested in assembly indicated according to ASTM E 90 and classified according to ASTM E 413 by an independent testing agency.
- C. Vapor Barrier Inspection: Where separate vapor barriers or faced batts are specified, a special inspection of the vapor barrier shall be performed prior to the installation of any gypsum board or other finishes that would conceal the vapor barrier materials. The cost of inspection shall be borne by the Owner.
 - 1. The inspection of the vapor barrier shall review the following:
 - a. Visually inspect the membrane for correct lapping of seams, sealing and taping of joints, sealing of penetrations, flashing overlap at window and door openings, and overall vapor barrier coverage.
 - b. Visually inspect the membrane for punctures, tears, or loose seams.
 - c. Confirm the membrane is continuous and extends with overlap to all wall plane edges.

2. Vapor barriers shall be repaired or replaced to achieve a continuous, fully sealed membrane. Repairs shall conform to vapor barrier manufacturer's recommended materials and methods. Repaired areas shall be re-inspected prior to enclosure.
3. Repeat inspections shall be scheduled as needed to review all vapor barrier installations prior to enclosure. Inspector shall file a written report of observations and any repair procedures, in accordance with Division 01.

1.5 STORAGE AND HANDLING

- A. Store materials inside under cover and keep them dry and protected against damage from weather, condensation, direct sunlight, construction traffic, and other causes. Stack panels flat to prevent sagging.

1.6 PROJECT CONDITIONS

- A. Environmental Limitations: Comply with ASTM C 840 requirements or gypsum board manufacturer's written recommendations, whichever are more stringent.
- B. Do not install interior products until installation areas are enclosed and conditioned.
- C. Do not install panels that are wet, those that are moisture damaged, and those that are mold damaged.
 1. Indications that panels are wet or moisture damaged include, but are not limited to, discoloration, sagging, or irregular shape.
 2. Indications that panels are mold damaged include, but are not limited to, fuzzy or blotchy surface contamination and discoloration.

PART 2 - PRODUCTS

2.1 PANELS, GENERAL

- A. Size: Provide in maximum lengths and widths available that will minimize joints in each area and that correspond with support system indicated.

2.2 INTERIOR GYPSUM BOARD

- A. General: Complying with ASTM C 36/C 36M or ASTM C 1396/C 1396M, as applicable to type of gypsum board indicated and whichever is more stringent.
 1. Available Manufacturers: Subject to compliance with requirements, manufacturers offering products that may be incorporated into the Work include, but are not limited to, the following:
 - a. American Gypsum Co.
 - b. CertainTeed.
 - c. G-P Gypsum.
 - d. Lafarge North America Inc.

- e. National Gypsum Company.
- f. USG Corporation.

B. All Walls and Ceilings indicated to have gypsum board shall use moisture- and mold-resistant gypsum board.

C. Moisture- and Mold-Resistant Gypsum Board: ASTM C 1396/C 1396M. With moisture- and mold-resistant core and paper surfaces.

- 1. Core: Walls: 5/8 inch.
 - a. Ceilings: 1/2 inch.
- 2. Long Edges: Tapered.
- 3. Acceptable products: Equivalent to Sheetrock® brand Mold Tough™ by USG Corporation.

D. Gypsum Board, Type X: ASTM C 1396/C 1396M.

- 1. Thickness: 5/8 inch unless noted otherwise
 - a. Follow UL Design thicknesses.
- 2. Long Edges: Tapered.

2.3 TRIM ACCESSORIES

A. Interior Trim: ASTM C 1047.

- 1. Material: Galvanized or aluminum-coated steel sheet or rolled zinc.
- 2. Shapes:
 - a. Cornerbead.
 - b. LC-Bead: J-shaped; exposed long flange receives joint compound.
 - c. L-Bead: L-shaped; exposed long flange receives joint compound.
 - d. U-Bead: J-shaped; exposed short flange does not receive joint compound.
 - e. Expansion (control) joint.
 - f. Curved-Edge Cornerbead: With notched or flexible flanges.

B. Aluminum Trim: Extruded accessories of exposed reveal profiles and dimensions indicated.

- 1. Available Manufacturers: Subject to compliance with requirements, manufacturers offering products that may be incorporated into the Work include, but are not limited to, the following:
 - a. Fry Reglet Corp.
 - b. Gordon, Inc.
 - c. Pitcon Industries.

2.4 JOINT TREATMENT MATERIALS

A. General: Comply with ASTM C 475/C 475M.

- B. Joint Tape:
 - 1. Interior Gypsum Wallboard: Fiberglass mesh.
 - 2. Tile Backing Panels: As recommended by panel manufacturer.
- C. Joint Compound for Interior Gypsum Wallboard: For each coat use formulation that is compatible with other compounds applied on previous or for successive coats.
 - 1. Prefilling: At open joints and damaged surface areas, use setting-type taping compound.
 - 2. Embedding and First Coat: For embedding tape and first coat on joints, fasteners, and trim flanges, use setting-type taping compound.
 - 3. Fill Coat: For second coat, use setting-type, sandable topping compound.
 - 4. Finish Coat: For third coat, use drying-type, all-purpose compound.

2.5 AUXILIARY MATERIALS

- A. General: Provide auxiliary materials that comply with referenced installation standards and manufacturer's written recommendations.
- B. Laminating Adhesive: Adhesive or joint compound recommended for directly adhering gypsum panels to continuous substrate.
 - 1. Use adhesives that have a VOC content of 50 g/L or less when calculated according to 40 CFR 59, Subpart D (EPA Method 24).
- C. Steel Drill Screws: ASTM C 1002, unless otherwise indicated.
 - 1. Use screws complying with ASTM C 954 for fastening panels to steel members from 0.033 to 0.112 inch thick.
 - 2. For fastening cementitious backer units, use screws of type and size recommended by panel manufacturer.
- D. Thermal Insulation: As specified in Division 7 Section "Thermal Insulation".

PART 3 - EXECUTION

3.1 EXAMINATION

- A. Examine areas and substrates, with Installer present, and including welded hollow-metal frames and framing, for compliance with requirements and other conditions affecting performance.
- B. Examine panels before installation. Reject panels that are wet, moisture damaged, and mold damaged.
- C. Proceed with installation only after unsatisfactory conditions have been corrected.

3.2 APPLYING AND FINISHING PANELS, GENERAL

- A. Comply with ASTM C 840.

- B. Install ceiling panels across framing to minimize the number of abutting end joints and to avoid abutting end joints in central area of each ceiling. Stagger abutting end joints of adjacent panels not less than one framing member.
- C. Install panels with face side out. Butt panels together for a light contact at edges and ends with not more than 1/16 inch of open space between panels. Do not force into place.
- D. Locate edge and end joints over supports, except in ceiling applications where intermediate supports or gypsum board back-blocking is provided behind end joints. Do not place tapered edges against cut edges or ends. Stagger vertical joints on opposite sides of partitions. Do not make joints other than control joints at corners of framed openings.
- E. Form control and expansion joints with space between edges of adjoining gypsum panels.
- F. Cover both faces of support framing with gypsum panels in concealed spaces (above ceilings, etc.), except in chases braced internally.
 - 1. Unless concealed application is indicated or required for sound, fire, air, or smoke ratings, coverage may be accomplished with scraps of not less than 8 sq. ft. in area.
 - 2. Fit gypsum panels around ducts, pipes, and conduits.
 - 3. Where partitions intersect structural members projecting below underside of floor/roof slabs and decks, cut gypsum panels to fit profile formed by structural members; allow 1/4- to 3/8-inch- wide joints to install sealant.
- G. Isolate perimeter of gypsum board applied to non-load-bearing partitions at structural abutments, except floors. Provide 1/4- to 1/2-inch- wide spaces at these locations, and trim edges with edge trim where edges of panels are exposed. Seal joints between edges and abutting structural surfaces with acoustical sealant.
- H. Attachment to Steel Framing: Attach panels so leading edge or end of each panel is attached to open (unsupported) edges of stud flanges first.
- I. STC-Rated Assemblies: Seal construction at perimeters, behind control joints, and at openings and penetrations with a continuous bead of acoustical sealant. Install acoustical sealant at both faces of partitions at perimeters and through penetrations. Comply with ASTM C 919 and with manufacturer's written recommendations for locating edge trim and closing off sound-flanking paths around or through assemblies, including sealing partitions above acoustical ceilings.
 - 1. Install Thickness of unfaced glass-fiber blanket insulation full heights of walls or to rated horizontal sound barriers so that walls to not allow flanking paths to develop across rated partitions.

3.3 APPLYING INTERIOR GYPSUM BOARD

- A. Single-Layer Application:
 - 1. On ceilings, apply gypsum panels before wall/partition board application to greatest extent possible and at right angles to framing, unless otherwise indicated.
 - 2. On partitions/walls, apply gypsum panels vertically (parallel to framing), unless otherwise indicated or required by fire-resistance-rated assembly, and minimize end joints.

- a. Stagger abutting end joints not less than one framing member in alternate courses of panels.
 - b. At stairwells and other high walls, install panels horizontally, unless otherwise indicated or required by fire-resistance-rated assembly.
3. Fastening Methods: Apply gypsum panels to supports with steel drill screws.
- B. Multilayer Application:
1. On ceilings, apply gypsum board indicated for base layers before applying base layers on walls/partitions; apply face layers in same sequence. Apply base layers at right angles to framing members and offset face-layer joints 1 framing member, 16 inches minimum, from parallel base-layer joints, unless otherwise indicated or required by fire-resistance-rated assembly.
 2. On partitions/walls, apply gypsum board indicated for base layers and face layers vertically (parallel to framing) with joints of base layers located over stud or furring member and face-layer joints offset at least one stud or furring member with base-layer joints, unless otherwise indicated or required by fire-resistance-rated assembly. Stagger joints on opposite sides of partitions.
 3. Fastening Methods: Fasten base layers with screws; fasten face layers with adhesive and supplementary fasteners.
- C. Laminating to Substrate: Where gypsum panels are indicated as directly adhered to a substrate (other than studs, joists, furring members, or base layer of gypsum board), comply with gypsum board manufacturer's written recommendations and temporarily brace or fasten gypsum panels until fastening adhesive has set.

3.4 INSTALLING TRIM ACCESSORIES

- A. General: For trim with back flanges intended for fasteners, attach to framing with same fasteners used for panels. Otherwise, attach trim according to manufacturer's written instructions.
- B. Control Joints: Install control joints according to ASTM C 840 and in specific locations approved by Architect for visual effect.
- C. Interior Trim: Install in the following locations:
1. Cornerbead: Use at outside corners.
 2. LC-Bead: Use at edges abutting dissimilar materials.
 3. L-Bead: Use where indicated.
 4. U-Bead: Use at exposed panel edges.
 5. Curved-Edge Cornerbead: Use at curved openings.
- D. Aluminum Trim Expansion Joints: Install in locations indicated on Drawings.
- E. Aluminum specialty reveals and mouldings: Apply where indicated with end closures provided by moulding manufacturer for exposed end conditions. Closure shall conform to moulding shape and be finished to match moulding.

1. Installer shall align gypsum board reveals to reveals in adjacent surfaces where shapes are shown to run continuous through gypsum and dissimilar materials.

3.5 FINISHING GYPSUM BOARD

- A. General: Treat gypsum board joints, interior angles, edge trim, control joints, penetrations, fastener heads, surface defects, and elsewhere as required to prepare gypsum board surfaces for decoration. Promptly remove residual joint compound from adjacent surfaces.
- B. Prefill open joints and damaged surface areas.
- C. Apply joint tape over gypsum board joints, except those with trim having flanges not intended for tape.
- D. Gypsum Board Finish Levels: Finish panels to levels indicated below and according to ASTM C 840:
 1. Level 3: All areas not exposed to view.
 2. Level 5: Surfaces exposed to view.
 - a. Primer and its application to surfaces are specified in other Division 9 Sections.

3.6 PROTECTION

- A. Protect installed products from damage from weather, condensation, direct sunlight, construction, and other causes during remainder of the construction period.
- B. Remove and replace panels that are wet, moisture damaged, and mold damaged.
 1. Indications that panels are wet or moisture damaged include, but are not limited to, discoloration, sagging, or irregular shape.
 2. Indications that panels are mold damaged include, but are not limited to, fuzzy or splotchy surface contamination and discoloration.

END OF SECTION 092900

SECTION 093000 - TILING

PART 1 - GENERAL

1.1 RELATED DOCUMENTS

- A. Drawings and general provisions of the Contract, including General and Supplementary Conditions and Division 01 Specification Sections, apply to this Section.

1.2 SUMMARY

- A. This Section includes the following:
 - 1. Ceramic tile.
 - 2. Porcelain wall and floor tile.
 - 3. Metal edge strips installed as part of tile installations.
 - 4. Exterior Porcelain 2cm thick paver.
- B. Related Sections include the following:
 - 1. Division 07 Section "Joint Sealants" for sealing of expansion, contraction, control, and isolation joints in tile surfaces.

1.3 DEFINITIONS

- A. Facial Dimension: Nominal tile size as defined in ANSI A137.1.
- B. Rectified tile: Tile provided from manufacturer with ground edges, dimensionally uniform, square and true edges; with or without bevel edge features.

1.4 PERFORMANCE REQUIREMENTS

- A. Static Coefficient of Friction: For tile installed on walkway surfaces, provide products with the following values as determined by testing identical products per ASTM C 1028:
 - 1. Level Surfaces: Minimum 0.6.
 - 2. Step Treads: Minimum 0.6.
 - 3. Ramp Surfaces: Minimum 0.8.

1.5 SUBMITTALS

- A. Product Data: For each type of product indicated.
- B. Samples for Initial Selection: For each type of tile and grout indicated. Include Samples of accessories involving color selection.

- C. Samples for Verification:
 1. Full-size sample of each color and finish of tile.
 2. Full-size units of each type of trim and accessory for each color and finish required.
 3. Metal edge strips in 6-inch lengths.
- D. Master Grade Certificates: For each shipment, type, and composition of tile, signed by tile manufacturer and Installer.
- E. Product Certificates: For each type of product, signed by product manufacturer.
- F. Qualification Data: For Installer.
- G. Material Test Reports: For each tile-setting and -grouting product and special-purpose tile.

1.6 QUALITY ASSURANCE

- A. Source Limitations for Tile: Obtain all tile of same type and color or finish from one source or producer.
 1. Obtain tile from same production run and of consistent quality in appearance and physical properties for each contiguous area.
- B. Source Limitations for Setting and Grouting Materials: Obtain ingredients of a uniform quality for each mortar, adhesive, and grout component from a single manufacturer and each aggregate from one source or producer.
- C. Source Limitations for Other Products: Obtain each of the following products specified in this Section through one source from a single manufacturer for each product:
 1. Waterproofing.
 2. Joint sealants.
 3. Cementitious backer units.
 4. Metal edge strips.
- D. Preinstallation Conference: Conduct conference at Project site to comply with requirements in Division 01 Section "Project Management and Coordination."
- E. Maintain one copy on site, of the latest edition of the TCNA (Tile Council of North America 2018 Edition) Handbook and ANSI Standards series A108 / A118.

1.7 DELIVERY, STORAGE, AND HANDLING

- A. Deliver and store packaged materials in original containers with seals unbroken and labels intact until time of use. Comply with requirement in ANSI A137.1 for labeling sealed tile packages.
- B. Store tile and cementitious materials on elevated platforms, under cover, and in a dry location.

- C. Store aggregates where grading and other required characteristics can be maintained and contamination avoided.
- D. Store liquid latexes in unopened containers and protected from freezing.
- E. Handle tile that has temporary protective coating on exposed surfaces to prevent coated surfaces from contacting backs or edges of other units. If coating does contact bonding surfaces of tile, remove coating from bonding surfaces before setting tile.

1.8 PROJECT CONDITIONS

- A. Environmental Limitations: Do not install tile until construction in spaces is complete and ambient temperature and humidity conditions are maintained at the levels indicated in referenced standards and manufacturer's written instructions.

1.9 EXTRA MATERIALS

- A. Furnish extra materials described below that match products installed and that are packaged with protective covering for storage and identified with labels describing contents.
 - 1. Tile and Trim Units: Furnish quantity of full-size units equal to 3 percent of amount installed, for each type, composition, color, pattern, and size indicated.

PART 2 - PRODUCTS

2.1 MANUFACTURERS

- A. In other Part 2 articles where titles below introduce lists, the following requirements apply for product selection:
 - 1. Products: Subject to compliance with requirements, provide one of the products specified.
 - 2. Manufacturers: Subject to compliance with requirements, provide products by one of the manufacturers specified.
- B. Source Limitations for Tile: Obtain tile of each type and color or finish from single source or producer.
 - 1. Obtain tile of each type and color or finish from same production run and of consistent quality in appearance and physical properties for each contiguous area.
- C. Source Limitations for Setting and Grouting Materials: Obtain ingredients of a uniform quality for each mortar, adhesive, and grout component from single manufacturer and each aggregate from single source or producer.

2.2 PRODUCTS, GENERAL

- A. ANSI Ceramic Tile Standard: Provide tile that complies with ANSI A137.1, "Specifications for Ceramic Tile," for types, compositions, and other characteristics indicated.
 - 1. Provide tile complying with Standard grade requirements, unless otherwise indicated.
 - 2. For facial dimensions of tile, comply with requirements relating to tile sizes specified in Part 1 "Definitions" Article.
- B. ANSI Standards for Tile Installation Materials: Provide materials complying with ANSI standards referenced in "Setting and Grouting Materials" Article.
- C. Colors, Textures, and Patterns: Where manufacturer's standard products are indicated for tile, grout, and other products requiring selection of colors, surface textures, patterns, and other appearance characteristics, provide specific products or materials complying with the following requirements:
 - 1. As indicated on drawings.
- D. Factory Blending: For tile exhibiting color variations within ranges selected during Sample submittals, blend tile in factory and package so tile units taken from one package show same range in colors as those taken from other packages and match approved Samples.
- E. Mounting: For factory-mounted tile, provide back- or edge-mounted tile assemblies as standard with manufacturer, unless otherwise indicated.
 - 1. Where tile is indicated for installation in areas continually exposed to moisture, do not use back- or edge-mounted tile assemblies unless tile manufacturer specifies in writing that this type of mounting is suitable for installation indicated and has a record of successful in-service performance.

2.3 TILE PRODUCTS

- A. Tile Type [TL-1] Floor tile
 - 1. Basis-of-Design Product: Subject to compliance with requirements, provide Dal-Tile Volume 1.0 series or comparable product by one of the following:
 - a. American Olean Corporation.
 - b. Florida Tile Inc.
 - 2. Composition: porcelain
 - 3. Face Size: 12"x24"
 - 4. Thickness: 3/8 inch.
 - 5. Wearing Surface: Nonabrasive, smooth
 - 6. Dynamic Coefficient of Friction: Not less than 0.42.
 - 7. Finish: unpolished.
 - 8. Tile Color and Pattern: Naval VL67 (color): Final selection by Architect from manufacturer's full range.
 - 9. Grout Color: As selected by Architect from manufacturer's full range.
 - 10. Grout Joint: 1/8" unless noted otherwise.

B. Tile Type [WLTL-1] Wall tile

1. Basis-of-Design Product: Subject to compliance with requirements, provide Dal-Tile “Stencil” series or comparable product by one of the following:
 - a. American Olean
 - b. Florida Tile Inc.
2. Composition: porcelain
3. Face Size: 4x12
4. Thickness: 5/16 inch.
5. Finish: gloss
6. Tile Color and Pattern: White SC32 (color) / Flat (no pattern) Modern Dimensions (pattern): Final selection by Architect from manufacturer's full range.
7. Grout Color: As selected by Architect from manufacturer's full range.
8. Grout Joint: 1/8” unless noted otherwise.

C. Accent Tile Type [WLTL-2] Wall tile

1. Basis-of-Design Product: Subject to compliance with requirements, provide Dal-Tile “Stencil” series or comparable product by one of the following:
 - a. American Olean
 - b. Florida Tile Inc.
2. Composition: porcelain
3. Face Size: 4x12
4. Thickness: 5/16 inch.
5. Finish: gloss
6. Tile Color and Pattern Grey SC34 and Indigo SC38 (color) Linear tile (pattern): Final selection by Architect from manufacturer's full range.
7. Grout Color: As selected by Architect from manufacturer's full range.
8. Grout Joint: 1/8” unless noted otherwise.

D. Exterior Porcelain 2cm thick paver [PV-1]

1. Basis-of-Design Product: Subject to compliance with requirements, provide Dal Tile – “Delegate” Tread paver series or comparable product by one of the following:
 - a. Edward Martine ‘Wren’
 - b. Florida Tile Inc.: ‘High ridge’ – Rockwall Gray
2. Composition: porcelain
3. Face Size: 20x40
4. Thickness: 2cm
5. Finish: mat
6. Tile Color and Pattern: Dark Grey DL27: Final selection by Architect from manufacturer's full range. See drawing for lay pattern.
7. Grout Color: As selected by Architect from manufacturer's full range.
8. Grout Joint: per manufacturer’s specification.

2.4 ACCESSORY MATERIALS

- A. Thresholds: Provide metal edge strips as indicated on drawings.
 - 1. Schluter or approved equal.
- B. Crack-Suppression Membranes for Thin-Set Tile Installations: Manufacturer's standard product that complies with ANSI A118.10.

2.5 WATERPROOF MEMBRANE

- A. General: Manufacturer's standard product that complies with ANSI A118.10 and is recommended by the manufacturer for the application indicated. Include reinforcement and accessories recommended by manufacturer.
- B. Fluid-Applied Membrane: Liquid-latex rubber or elastomeric polymer.
 - a. Basis-of-Design Product: Subject to compliance with requirements, provide Custom Building Products; RedGard Waterproofing and Crack Prevention Membrane or comparable product by one of the approved manufacturers.
 - b. Ardex Americas.
 - c. Bonsal American, an Oldcastle company; B 6000 Waterproof-Crack Isolation Membrane.
 - d. Bostik, Inc.
 - e. Laticrete International, Inc.
 - f. MAPEI Corporation.

2.6 SETTING AND GROUTING MATERIALS

- A. Manufacturers:
 - 1. Custom Building Products.
 - 2. LATICRETE International Inc.
 - 3. MAPEI Corporation.
 - 4. MerKrete
 - 5. TEC Specialty Products Inc.
- B. Latex-Portland Cement Mortar (Thin Set): ANSI A118.4, consisting of the following:
 - 1. Prepackaged dry-mortar mix combined with acrylic resin liquid-latex additive.
 - a. For wall applications, provide nonsagging mortar that complies with Paragraph F-4.6.1 in addition to the other requirements in ANSI A118.4.
- C. Medium-Bed, Latex-Portland Cement Mortar (vertical and horizontal applications): Provide materials composed as follows, with physical properties equaling or exceeding those required for thin-set mortars based on testing of medium-bed specimens according to ANSI A118.4:
 - 1. Prepackaged dry-mortar mix combined with acrylic resin liquid-latex additive.
- D. Polymer-Modified Tile Grout: ANSI A118.7, color as indicated.

1. Polymer Type: Ethylene vinyl acetate, in dry, redispersible form, prepackaged with other dry ingredients, acrylic resin in liquid-latex form for addition to prepackaged dry-grout mix.
 - a. Unsanded grout mixture for joints 1/8 inch and narrower.
 - b. Sanded grout mixture for joints 1/8 inch and wider.
- E. Use only white thin-set with installation of translucent and transparent glass tile or stone.

2.7 ELASTOMERIC SEALANTS

- A. General: Provide manufacturer's standard chemically curing, elastomeric sealants of base polymer and characteristics indicated that comply with applicable requirements in Division 07 Section "Joint Sealants."
 1. Use sealants that have a VOC content of 250 g/L or less when calculated according to 40 CFR 59, Subpart D (EPA Method 24).
- B. Colors: Provide colors of exposed sealants to match colors of grout in tile adjoining sealed joints, unless otherwise indicated.

2.8 MISCELLANEOUS MATERIALS

- A. Trowelable Underlayments and Patching Compounds: Latex-modified, portland cement-based formulation provided or approved by manufacturer of tile-setting materials for installations indicated.
- B. Metal Edge Strips: Height to match tile and setting-bed thickness, metallic designed specifically for flooring and vertical outside corner applications, exposed-edge material.
 1. Floor: Sheine by Schluter or approved equal in profile, material, and finish to types indicated.
 2. Walls: Rondec by Schluter as approved equal in profile, material, and finish to types indicated.
- C. Temporary Protective Coating: Product indicated below that is formulated to protect exposed surfaces of tile against adherence of mortar and grout; compatible with tile, mortar, and grout products; and easily removable after grouting is completed without damaging grout or tile.
 1. Grout release in form of manufacturer's standard proprietary liquid coating that is specially formulated and recommended for use as temporary protective coating for tile.
 - a. Grout Release by Aqua Mix or approved equal.
- D. Tile Cleaner: A neutral cleaner capable of removing soil and residue without harming tile and grout surfaces, specifically approved for materials and installations indicated by tile and grout manufacturers.

2.9 MIXING MORTARS AND GROUT

- A. Mix mortars and grouts to comply with referenced standards and mortar and grout manufacturers' written instructions.
- B. Add materials, water, and additives in accurate proportions.
- C. Obtain and use type of mixing equipment, mixer speeds, mixing containers, mixing time, and other procedures to produce mortars and grouts of uniform quality with optimum performance characteristics for installations indicated.

PART 3 - EXECUTION

3.1 EXAMINATION

- A. Examine substrates, areas, and conditions where tile will be installed, with Installer present, for compliance with requirements for installation tolerances and other conditions affecting performance of installed tile.
 - 1. Verify that substrates for setting tile are firm; dry; clean; free of oil, waxy films, and curing compounds; and within flatness tolerances required by referenced ANSI A108 Series of tile installation standards for installations indicated.
 - 2. Verify that installation of grounds, anchors, recessed frames, electrical and mechanical units of work, and similar items located in or behind tile has been completed before installing tile.
 - 3. Verify that joints and cracks in tile substrates are coordinated with tile joint locations; if not coordinated, adjust joint locations in consultation with Architect.
- B. Proceed with installation only after unsatisfactory conditions have been corrected.

3.2 PREPARATION

- A. Remove coatings, including curing compounds and other substances that contain soap, wax, oil, or silicone, that are incompatible with tile-setting materials.
- B. Provide concrete substrates for tile floors installed with thin-set mortar that comply with flatness tolerances specified in referenced ANSI A108 Series of tile installation standards.
 - 1. Fill cracks, holes, and depressions with trowelable leveling and patching compound according to tile-setting material manufacturer's written instructions. Use product specifically recommended by tile-setting material manufacturer.
 - 2. Remove protrusions, bumps, and ridges by sanding or grinding.
- C. Tile to vertical steel preparation: Remove any painted coatings down to bare metal. Scarify surface.
- D. Blending: For tile exhibiting color variations within ranges selected during Sample submittals, verify that tile has been factory blended and packaged so tile units taken from one package

show same range of colors as those taken from other packages and match approved Samples. If not factory blended, either return to manufacturer or blend tiles at Project site before installing.

- E. Field-Applied Temporary Protective Coating: Where indicated under tile type or needed to prevent grout from staining or adhering to exposed tile surfaces, precoat them with continuous film of temporary protective coating, taking care not to coat unexposed tile surfaces.

3.3 INSTALLATION, GENERAL

- A. ANSI Tile Installation Standards: Comply with parts of ANSI A108 Series "Specifications for Installation of Ceramic Tile" that apply to types of setting and grouting materials and to methods indicated in ceramic tile installation schedules.
- B. TCNA Installation Guidelines: TCNA's "Handbook for Ceramic Tile Installation." Comply with TCNA installation methods indicated in ceramic tile installation schedules and complying with the following:
 - 1. Floor tile 12 x 12 inch or greater: Finish tolerance of 1/8 inch in 10 feet (non-cumulative.)
 - a. Tile exceeding 18 x 18 inches: finish tolerance to 1/16 inch in 10 feet.
 - 2. Installer shall review F-number test reports and identify in writing where concrete slab floor flatness tolerances will prevent meeting finish tolerances specified herein. Arrange with Contractor to have missing F-number tests completed and correct any substrate deficiencies prior to commencing tile installation.
- C. Extend tile work into recesses and under or behind equipment and fixtures to form complete covering without interruptions, unless otherwise indicated. Terminate work neatly at obstructions, edges, and corners without disrupting pattern or joint alignments.
- D. Accurately form intersections and returns. Perform cutting and drilling of tile without marring visible surfaces. Carefully grind cut edges of tile abutting trim, finish, or built-in items for straight aligned joints. Fit tile closely to electrical outlets, piping, fixtures, and other penetrations so plates, collars, or covers overlap tile.
- E. Jointing Pattern: Lay tile in grid pattern, unless otherwise indicated. Align joints when adjoining tiles on floor, base, walls, and trim are same size. Lay out tile work and center tile fields in both directions in each space or on each wall area. Adjust to minimize tile cutting. Provide uniform joint widths, unless otherwise indicated.
 - 1. For tile mounted in sheets, make joints between tile sheets same width as joints within tile sheets so joints between sheets are not apparent in finished work.
 - 2. Refer to tile patterns indicated.
- F. Lay out tile wainscots to next full tile; Refer to patterns and details indicated.
- G. Expansion Joints: Locate expansion joints and other sealant-filled joints, including control, contraction, and isolation joints, where indicated during installation of setting materials, mortar beds, and tile. Do not saw-cut joints after installing tiles.

1. Locate joints in tile surfaces directly above joints in concrete substrates.
2. Prepare joints and apply sealants to comply with requirements in Division 07 Section "Joint Sealants."

H. Grout tile to comply with requirements of the following tile installation standards:

1. For ceramic tile grouts (sand-portland cement; dry-set, commercial portland cement; and latex-portland cement grouts), comply with ANSI A108.10.

3.4 WATERPROOFING AND /OR CRACK-SUPPRESSION MEMBRANE INSTALLATION

- A. Install waterproofing to comply with ANSI A108.13 and waterproofing manufacturer's written instructions to produce waterproof membrane of uniform thickness bonded securely to substrate.
- B. Install crack-suppression membrane to comply with manufacturer's written instructions to produce membrane of uniform thickness bonded securely to substrate.
- C. Do not install tile over waterproofing until waterproofing has cured and been tested to determine that it is watertight.

3.5 FLOOR TILE INSTALLATION

- A. General: Install tile to comply with requirements in the Floor Tile Installation Schedule, including those referencing TCNA installation methods and ANSI A108 Series of tile installation standards.
 1. Follow TCNA procedures for 95% mortar coverage.
- B. Joint Widths: Install tile on floors with the following joint widths:
 1. As indicated in Tile Products section 2.3.
- C. Metal Edge Strips: Install at locations indicated or where exposed edge of tile flooring meets carpet, wood, or other flooring that finishes flush with top of tile.

3.6 WALL TILE INSTALLATION

- A. Install types of tile designated for wall installations to comply with requirements in the Wall Tile Installation Schedule, including those referencing TCNA installation methods and ANSI setting-bed standards.
- B. Install 12 x 12 or greater size wall tile over medium-bed latex modified mortar. Adjust grout joint widths with the prior approval of the Architect, if needed to improve tile edge to edge alignment of standard and rectified tiles.
- C. Metal Edge Strips: Install at locations indicated and at outside corners.

3.7 CLEANING AND PROTECTING

- A. Cleaning: On completion of placement and grouting, clean all ceramic tile surfaces so they are free of foreign matter.
 - 1. Remove latex-portland cement grout residue from tile as soon as possible.
 - 2. Clean grout smears and haze from tile according to tile and grout manufacturer's written instructions, but no sooner than 10 days after installation. Use only cleaners recommended by tile and grout manufacturers and only after determining that cleaners are safe to use by testing on samples of tile and other surfaces to be cleaned. Protect metal surfaces and plumbing fixtures from effects of cleaning. Flush surfaces with clean water before and after cleaning.
 - 3. Remove temporary protective coating by method recommended by coating manufacturer that is acceptable to tile and grout manufacturer. Trap and remove coating to prevent it from clogging drains.
- B. For unglazed tiles and stone products apply coat of neutral protective cleaner grout release to completed tile walls and floors. Protect installed tile work with kraft paper or other heavy covering during construction period to prevent staining, damage, and wear.
- C. Prohibit foot and wheel traffic from tiled floors for at least seven days after grouting is completed.
- D. Before final inspection, remove protective coverings and rinse neutral cleaner from tile surfaces.

3.8 TILE INSTALLATION SCHEDULE

- A. Floor Tile Installation: Interior floor installations sloped to drain on concrete; cement mortar bed (thickset) with cleavage membrane; TCNA F111-23 and ANSI A108.1A.
 - 1. Tile Type: As indicated on drawings.
 - 2. Thin-Set Mortar: Latex- portland cement mortar.
 - 3. Grout: Polymer-modified sanded grout.
- B. Floor Tile Installation: Interior floor installation on concrete; thin-set mortar; TCNA F122A-23 and ANSI A118.4.
 - 1. Tile Type: As indicated on drawings.
 - 2. Thin-Set Mortar: Latex- portland cement mortar.
 - 3. Grout: Polymer-modified sanded or Polymer-modified unsanded grout per joint size and tile type indicated.
 - 4. Tiles exceeding 12 inches x 12 inches nominal; provide medium mortar bed.
- C. Paver Tile Installation: Exterior floor installation on-ground concrete, thickset; TCNA F101-23 and ANSI A108.1A.
 - 1. Tile Type: As indicated on drawings.
 - 2. Bond Coat for cured-bed method: Latex-portland cement mortar.
 - 3. Grout: Polymer-modified sanded grout.

- D. Wall Tile Installation: Interior wall installation over sound, dimensionally stable masonry or concrete; thin-set mortar; TCNA W202E-23 and ANSI A118.4 and ANSI A118.6.
1. Tile Type: As indicated on drawings.
 2. Thin-Set Mortar: Latex- portland cement mortar.
 3. Medium bed Mortar for large format tiles.
 4. Grout: Polymer-modified sanded or Polymer-modified unsanded grout per joint size and tile type indicated.
- E. Movement Joint Installation: Comply with TCNA standards for location and frequency of joints, including, but not limited to:
1. Interior – maximum of 25’ in each direction and as indicated on drawings.
 2. Change of plane, interior – movement joints required at all inside corners.
 3. Perimeter Joints – movement joints are required where tilework abuts restraining surfaces such as perimeter walls, dissimilar floor finishes, curbs, columns, pipes, ceilings, and where changes occur in backing materials, but not at drain stainers.
 4. All expansion, control, construction, cold, saw-cut, isolation, contraction, and seismic joints in the structure should continue through the tilework, including such joints at vertical surfaces.

END OF SECTION 093000

SECTION 095113 - ACOUSTICAL PANEL CEILINGS

PART 1 - GENERAL

1.1 RELATED DOCUMENTS

- A. Drawings and general provisions of the Contract, including General and Supplementary Conditions and Division 01 Specification Sections, apply to this Section.

1.2 SUMMARY

- A. Section includes acoustical panels and exposed suspension systems for ceilings.
- B. Products furnished, but not installed under this Section, include anchors, clips, and other ceiling attachment devices to be cast in concrete.

1.3 PREINSTALLATION MEETINGS

- A. Preinstallation Conference: Conduct conference at Project site.

1.4 ACTION SUBMITTALS

- A. Product Data: For each type of product.
- B. Samples: For each exposed product and for each color and texture specified, 6 inches in size.
- C. Samples for Initial Selection: For components with factory-applied color finishes.
- D. Samples for Verification: For each component indicated and for each exposed finish required, prepared on Samples of size indicated below.
 - 1. Acoustical Panel: Set of 6-inch-square samples of each type, color, pattern, and texture.
 - 2. Exposed Suspension-System Members, Moldings, and Trim: Set of 6-inch-long samples of each type, finish, and color.
- E. Warranty: Provide manufacturer's written warranty for type of product.

1.5 INFORMATIONAL SUBMITTALS

- A. Coordination Drawings: Reflected ceiling plans, drawn to scale, on which the following items are shown and coordinated with each other, using input from installers of the items involved:
 - 1. Suspended ceiling components.
 - 2. Structural members to which suspension systems will be attached.
 - 3. Size and location of initial access modules for acoustical panels.

4. Items penetrating finished ceiling including the following:

- a. Lighting fixtures.
- b. Air outlets and inlets.
- c. Speakers.
- d. Sprinklers.
- e. Access panels.

- A. Product Test Reports: For each acoustical panel ceiling, for tests performed by An independent testing laboratory or an NVLAP-accredited laboratory.
- B. Evaluation Reports: For each acoustical panel ceiling suspension system and anchor and fastener type, from ICC-ES.

1.6 CLOSEOUT SUBMITTALS

- A. Maintenance Data: For finishes to include in maintenance manuals.

1.7 MAINTENANCE MATERIAL SUBMITTALS

- A. Furnish extra materials that match products installed and that are packaged with protective covering for storage and identified with labels describing contents.
 1. Acoustical Ceiling Panels: Full-size panels equal to 2 percent of quantity installed.
 2. Suspension-System Components: Quantity of each exposed component equal to 2 percent of quantity installed.
 3. Hold-Down Clips: Equal to 2 percent of quantity installed.
 4. Impact Clips: Equal to 2 percent of quantity installed.

1.8 QUALITY ASSURANCE

- A. Testing Agency Qualifications: Qualified according to NVLAP for testing indicated.

1.9 DELIVERY, STORAGE, AND HANDLING

- A. Deliver acoustical panels, suspension-system components, and accessories to Project site in original, unopened packages and store them in a fully enclosed, conditioned space where they will be protected against damage from moisture, humidity, temperature extremes, direct sunlight, surface contamination, and other causes.
- B. Before installing acoustical panels, permit them to reach room temperature and a stabilized moisture content.
- C. Handle acoustical panels carefully to avoid chipping edges or damaging units in any way.

1.10 FIELD CONDITIONS

- A. Environmental Limitations: Do not install acoustical panel ceilings until spaces are enclosed and weatherproof, wet work in spaces is complete and dry, work above ceilings is complete, and ambient temperature and humidity conditions are maintained at the levels indicated for Project when occupied for its intended use.
 - 1. Pressurized Plenums: Operate ventilation system for not less than 48 hours before beginning acoustical panel ceiling installation.

PART 2 - PRODUCTS

2.1 PERFORMANCE REQUIREMENTS

- A. Seismic Performance: Acoustical ceiling shall be installed in accordance with CISCA publication "Seismic (Zones 0-2) Recommendations for Direct-hung Acoustical Tile and Lay-in Panel Ceilings".
- B. Surface-Burning Characteristics: Comply with ASTM E 84; testing by a qualified testing agency. Identify products with appropriate markings of applicable testing agency.
 - 1. Flame-Spread Index: Comply with ASTM E 1264 for Class A materials; 25 or less.
 - 2. Smoke-Developed Index: 50 or less.
- C. Fire-Resistance Ratings: Comply with ASTM E 119; testing by a qualified testing agency. Identify products with appropriate markings of applicable testing agency.
 - 1. Indicate design designations from UL's "Fire Resistance Directory" or from the listings of another qualified testing agency.

2.2 ACOUSTICAL PANELS, GENERAL

- A. Source Limitations: Obtain each type of acoustical ceiling panel and supporting suspension system from single source from single manufacturer.
- B. Glass-Fiber-Based Panels: Made with binder containing no urea formaldehyde.
- C. Acoustical Panel Standard: Provide manufacturer's standard panels of configuration indicated that comply with ASTM E 1264 classifications as designated by types, patterns, acoustical ratings, and light reflectances unless otherwise indicated.
- D. Acoustical Panel Colors and Patterns: Match appearance characteristics indicated for each product type.
 - 1. Where appearance characteristics of acoustical panels are indicated by referencing pattern designations in ASTM E 1264 and not manufacturers' proprietary product designations, provide products selected by Architect from each manufacturer's full range that comply with requirements indicated for type, pattern, color, light reflectance, acoustical performance, edge detail, and size.

2.3 ACOUSTICAL PANELS – EGAP #1

- A. Basis-of-Design Product: Subject to compliance with requirements, provide “DUNE” with Angled Tegular edge profile #1774 as manufactured by Armstrong or comparable product by one of the following:
1. CertainTeed Corp.
 2. USG Interiors, Inc.; Subsidiary of USG Corporation.
- B. Classification: Provide panels complying with ASTM E 1264 for type, form, and pattern as follows:
1. Type and Form: Type III, mineral base with painted finish; Form 2, water felted.
 2. Pattern: CE (perforated, small holes and lightly textured).
 3. Fire Performance : Class A
- C. Color: White.
- D. LR: Not less than 0.81.
- E. NRC: Not less than 0.50.
- F. CAC: Not less than 35.
- G. Edge/Joint Detail: Armstrong “Angled Tegular.”
- H. Thickness: 5/8 inch.
- I. Modular Size: As indicated in room Finish Schedule and ceiling plans.
- J. Broad Spectrum Antimicrobial Fungicide and Bactericide Treatment: Provide acoustical panels treated with manufacturer's standard antimicrobial formulation that inhibits fungus, mold, mildew, and gram-positive and gram-negative bacteria and showing no mold, mildew, or bacterial growth when tested according to ASTM D 3273 and evaluated according to ASTM D 3274 or ASTM G 21.

2.4 METAL SUSPENSION SYSTEMS, GENERAL

- A. Metal Suspension-System Standard: Provide manufacturer's standard direct-hung metal suspension systems of types, structural classifications, and finishes indicated that comply with applicable requirements in ASTM C 635/C 635M.
- B. Attachment Devices: Size for five times the design load indicated in ASTM C 635/C 635M, Table 1, "Direct Hung," unless otherwise indicated. Comply with seismic design requirements.
- C. Wire Hangers, Braces, and Ties: Provide wires complying with the following requirements:
1. Zinc-Coated, Carbon-Steel Wire: ASTM A 641/A 641M, Class 1 zinc coating, soft temper.
 2. Stainless-Steel Wire: ASTM A 580/A 580M, Type 304, nonmagnetic.

3. Size: Select wire diameter so its stress at three times hanger design load (ASTM C 635/C 635M, Table 1, "Direct Hung") will be less than yield stress of wire, but provide not less than 0.106-inch-diameter wire.
- D. Hold-Down Clips: Where indicated, provide manufacturer's standard hold-down clips spaced 24 inches o.c. on all cross tees.
- E. Metal Edge Moldings and Trim: Type and profile indicated or, if not indicated, manufacturer's standard moldings for edges and penetrations that fit acoustical tile edge details and suspension systems indicated; formed from sheet metal of same material and finish as that used for exposed flanges of suspension system runners.

2.5 METAL SUSPENSION SYSTEM

- A. Basis-of-Design Product: Subject to compliance with requirements, provide "Prelude XL" as manufactured by Armstrong or comparable product by one of the following:
 1. CertainTeed Corp.
 2. USG Interiors, Inc.; Subsidiary of USG Corporation.
- B. Wide-Face, Capped, Double-Web, Fire-Rated when indicated, Steel Suspension System: Main and cross runners roll formed from cold-rolled steel sheet, prepainted, electrolytically zinc coated, or hot-dip galvanized according to ASTM A 653/A 653M, not less than G30 coating designation, with prefinished 15/16-inch- wide metal caps on flanges.
 1. Structural Classification: Intermediate-duty system.
 2. End Condition of Cross Runners: Butt edge type.
 3. Face Design: Flat, flush.
 4. Cap Material: Steel or aluminum cold-rolled sheet.

2.6 METAL EDGE MOLDINGS AND TRIM

- A. Manufacturers: Subject to compliance with requirements, available manufacturers offering products that may be incorporated into the Work include, but are not limited to, the following:
 1. Armstrong World Industries, Inc.
 2. CertainTeed Corp.
 3. Chicago Metallic Corporation.
 4. Fry Reglet Corporation.
 5. USG Interiors, Inc.; Subsidiary of USG Corporation.
- B. Roll-Formed, Sheet-Metal Edge Moldings and Trim: Type and profile indicated or, if not indicated, manufacturer's standard moldings for edges and penetrations that comply with seismic design requirements; formed from sheet metal of same material, finish, and color as that used for exposed flanges of suspension-system runners.
 1. Provide manufacturer's standard edge moldings that fit acoustical panel edge details and suspension systems indicated and that match width and configuration of exposed runners unless otherwise indicated.

2. For lay-in panels with reveal edge details, provide stepped edge molding that forms reveal of same depth and width as that formed between edge of panel and flange at exposed suspension member.
 3. For circular penetrations of ceiling, provide edge moldings fabricated to diameter required to fit penetration exactly.
- C. Extruded-Aluminum Edge Moldings and Trim: Where indicated, provide manufacturer's extruded-aluminum edge moldings and trim of profile indicated or referenced by manufacturer's designations, including splice plates, corner pieces, and attachment and other clips, complying with seismic design requirements and the following:
1. Aluminum Alloy: Alloy and temper recommended by aluminum producer and finisher for type of use and finish indicated, and with not less than the strength and durability properties of aluminum extrusions complying with ASTM B 221 for Alloy and Temper 6063-T5.
 2. Clear Anodic Finish: AAMA 611, AA-M12C22A31, Class II, 0.010 mm or thicker.
 3. Baked-Enamel or Powder-Coat Finish: Minimum dry film thickness of 1.5 mils. Comply with ASTM C 635/C 635M and coating manufacturer's written instructions for cleaning, conversion coating, and applying and baking finish.

2.7 INTERIOR SUSPENDED CEILING EXPANSION CONTROL SYSTEMS

1. General: Aluminum extrusion with elastomeric accordion fold insert specifically designed for acoustical panel suspension grid applications. Prefinished to match grid. Locations as indicated.
- B. Basis-of-Design Product: Subject to compliance with requirements, provide product indicated or a comparable product by one of the following:
1. Architectural Art Mfg., Inc.; Division of Pittcon Industries.
 2. Balco, Inc.
 3. Construction Specialties, Inc.
 4. JointMaster/InPro Corporation.
 5. MM Systems Corporation.
- C. Source Limitations: Obtain expansion control systems from single source from single manufacturer.
- D. Ceiling-to-Ceiling:
1. Basis-of-Design Product: Model DX by MM Systems, Inc.
 2. Design Criteria:
 - a. Nominal Joint Width: As indicated on Drawings.
 - b. Fire-Resistance Rating: Provide expansion control system and fire-barrier assembly with a rating not less than that of adjacent construction.
 3. Type: Accordion.
 4. Seal Material: Manufacturer's standard.

- a. Color: White.

PART 3 - EXECUTION

3.1 EXAMINATION

- A. Examine substrates, areas, and conditions, including structural framing to which acoustical panel ceilings attach or abut, with Installer present, for compliance with requirements specified in this and other Sections that affect ceiling installation and anchorage and with requirements for installation tolerances and other conditions affecting performance of acoustical panel ceilings.
- B. Examine acoustical panels before installation. Reject acoustical panels that are wet, moisture damaged, or mold damaged.
- C. Proceed with installation only after unsatisfactory conditions have been corrected.

3.2 PREPARATION

- A. Measure each ceiling area and establish layout of acoustical panels to balance border widths at opposite edges of each ceiling. Avoid using less-than-half-width panels at borders, and comply with layout shown on reflected ceiling plans.

3.3 INSTALLATION

- A. General: Install acoustical panel ceilings to comply with ASTM C 636/C 636M and seismic design requirements indicated, according to manufacturer's written instructions and CISCA's "Ceiling Systems Handbook."
 - 1. Fire-Rated Assembly: Install fire-rated ceiling systems according to tested fire-rated design.
 - 2. Seismic Installation: Follow CISCA publication "Seismic (Zones 0-2) Recommendations for Direct-hung Acoustical Tile and Lay-in Panel Ceilings."
- B. Suspend ceiling hangers from building's structural members and as follows:
 - 1. Install hangers plumb and free from contact with insulation or other objects within ceiling plenum that are not part of supporting structure or of ceiling suspension system.
 - 2. Splay hangers only where required and, if permitted with fire-resistance-rated ceilings, to miss obstructions; offset resulting horizontal forces by bracing, countersplaying, or other equally effective means.
 - 3. Where width of ducts and other construction within ceiling plenum produces hanger spacings that interfere with location of hangers at spacings required to support standard suspension-system members, install supplemental suspension members and hangers in form of trapezes or equivalent devices.
 - 4. Secure wire hangers to ceiling-suspension members and to supports above with a minimum of three tight turns. Connect hangers directly either to structures or to inserts,

- eye screws, or other devices that are secure and appropriate for substrate and that will not deteriorate or otherwise fail due to age, corrosion, or elevated temperatures.
5. Do not support ceilings directly from permanent metal forms or floor deck. Fasten hangers to cast-in-place hanger inserts, postinstalled mechanical or adhesive anchors, or power-actuated fasteners that extend through forms into concrete.
 6. When steel framing does not permit installation of hanger wires at spacing required, install carrying channels or other supplemental support for attachment of hanger wires.
 7. Do not attach hangers to steel deck tabs.
 8. Do not attach hangers to steel roof deck. Attach hangers to structural members.
 9. Space hangers not more than 48 inches o.c. along each member supported directly from hangers unless otherwise indicated; provide hangers not more than 8 inches from ends of each member.
 10. Size supplemental suspension members and hangers to support ceiling loads within performance limits established by referenced standards and publications.
- C. Install edge moldings and trim of type indicated at perimeter of acoustical ceiling area and where necessary to conceal edges of acoustical panels.
1. Apply acoustical sealant in a continuous ribbon concealed on back of vertical legs of moldings before they are installed.
 2. Screw attach moldings to substrate at intervals not more than 16 inches o.c. and not more than 3 inches from ends, leveling with ceiling suspension system to a tolerance of 1/8 inch in 12 feet. Miter corners accurately and connect securely.
 3. Do not use exposed fasteners, including pop rivets, on moldings and trim.
- D. Install suspension-system runners so they are square and securely interlocked with one another. Remove and replace dented, bent, or kinked members.
- E. Install acoustical panels with undamaged edges and fit accurately into suspension-system runners and edge moldings. Scribe and cut panels at borders and penetrations to provide a neat, precise fit.
1. Arrange directionally patterned acoustical panels as follows:
 - a. As indicated on reflected ceiling plans.
 2. For square-edged panels, install panels with edges fully hidden from view by flanges of suspension-system runners and moldings.
 3. For reveal-edged panels on suspension-system runners, install panels with bottom of reveal in firm contact with top surface of runner flanges.
 4. Paint cut edges of panel remaining exposed after installation; match color of exposed panel surfaces using coating recommended in writing for this purpose by acoustical panel manufacturer.
 5. Install hold-down clips in areas indicated, in areas required by authorities having jurisdiction, and for fire-resistance ratings; space as recommended by panel manufacturer's written instructions unless otherwise indicated.
 6. Protect lighting fixtures and air ducts to comply with requirements indicated for fire-resistance-rated assembly.

3.4 CLEANING

- A. Clean exposed surfaces of acoustical panel ceilings, including trim, edge moldings, and suspension-system members. Comply with manufacturer's written instructions for cleaning and touchup of minor finish damage. Remove and replace ceiling components that cannot be successfully cleaned and repaired to permanently eliminate evidence of damage.

END OF SECTION 095113

SECTION 095126 - ACOUSTICAL WOOD CEILINGS

PART 1 - GENERAL

1.1 RELATED DOCUMENTS

- A. Drawings and general provisions of the Contract, including General and Supplementary Conditions and Division 01 Specification Sections, apply to this Section.

1.2 SUMMARY

- A. Section includes acoustical wood panels and exposed suspension systems for interior ceilings.
- B. Related Requirements:
 - 1. Section 095113 "Acoustical Panel Ceilings" for ceilings consisting of mineral-base acoustical tiles used with fully concealed suspension systems, stapling, or adhesive bonding.
- C. Products furnished, but not installed under this Section, include anchors, clips, and other ceiling attachment devices.

1.3 PREINSTALLATION MEETINGS

- A. Preinstallation Conference: Conduct conference at Project site.

1.4 ACTION SUBMITTALS

- A. Product Data: For each type of product.
- B. Samples: For each exposed product and for each color and texture specified, 6 inches in size.
- C. Samples for Initial Selection: For components with factory-applied finishes.
- D. Samples for Verification: For each component indicated and for each exposed finish required, provide samples of sizes indicated below:
 - 1. Wood finish: Set of 6-inch square samples of each type, color, pattern, and texture.
 - 2. Assembly: Provide one assembly panel at least 24" long.
 - 3. Exposed Suspension-System Members, Moldings, and Trim: Set of 6-inch long Samples of each type, finish, and color.
 - 4. Clips: Full-size hold-down, impact and seismic clips.
 - 5. Acoustical infill panel: 6-inch square sample.
- E. Delegated-Design Submittal: For seismic restraints for ceiling systems.

1.5 INFORMATIONAL SUBMITTALS

- A. Coordination Drawings: Reflected ceiling plans, drawn to scale, on which the following items are shown and coordinated with each other, using input from installers of the items involved:
1. Ceiling suspension-system members.
 2. Structural members to which suspension systems will be attached.
 3. Method of attaching hangers to building structure.
 4. Carrying channels or other supplemental support for hanger-wire attachment where conditions do not permit installation of hanger wires at required spacing.
 5. Size and location of initial access modules for acoustical panels.
 6. Items penetrating finished ceiling and ceiling-mounted items including the following:
 - a. Lighting fixtures.
 - b. Diffusers.
 - c. Grilles.
 - d. Speakers.
 - e. Sprinklers.
 - f. Access panels.
 - g. Perimeter moldings.
 7. Show operation of hinged and sliding components covered by or adjacent to acoustical panels.
 8. Minimum Drawing Scale: 1/4 inch = 1 foot
- B. Qualification Data: For testing agency.
- C. Product Test Reports: Fire performance.

1.6 CLOSEOUT SUBMITTALS

- A. Maintenance Data: For finishes to include in maintenance manuals.

1.7 MAINTENANCE MATERIAL SUBMITTALS

- A. Furnish extra materials, from the same product run, that match products installed and that are packaged with protective covering for storage and identified with labels describing contents.
1. Acoustical Wood Ceiling Units: Full-size panels equal to 2 percent of quantity installed.
 2. Suspension-System Components: Quantity of each exposed component equal to 2 percent of quantity installed.
 3. Hold-Down Clips: Equal to 2 percent of quantity installed.
 4. Impact Clips: Equal to 2 percent of quantity installed.

1.8 QUALITY ASSURANCE

- A. Mockups: Build mockups to verify selections made under Sample submittals, to demonstrate aesthetic effects, and to set quality standards for materials and execution.

1. Build mockup of typical ceiling area as shown on Drawings.
2. Approval of mockups does not constitute approval of deviations from the Contract Documents contained in mockups unless Architect specifically approves such deviations in writing.
3. Subject to compliance with requirements, approved mockups may become part of the completed Work if undisturbed at time of Final Acceptance.

B. Single-Source Responsibility: Provide ceiling panel units and grid components by a single manufacturer.

C. Coordination of Work: Coordinate ceiling work with installers of related work including, but not limited to building insulation, wet work i.e. gypsum board, light fixtures, mechanical systems, electrical systems, and sprinklers.

1.9 DELIVERY, STORAGE, AND HANDLING

A. Deliver acoustical panels, suspension-system components, and accessories to Project site and store them in a fully enclosed, conditioned space where they will be protected against damage from moisture, humidity, temperature extremes, direct sunlight, surface contamination, and other causes.

B. Before installing acoustical panels, permit them to reach room temperature and a stabilized moisture content.

C. Handle ceiling units carefully to avoid chipped edges or damage to units in any way.

1.10 FIELD CONDITIONS

A. Environmental Limitations: Do not install acoustical panel ceilings until spaces are enclosed and weathertight, wet-work in spaces is complete and dry, work above ceilings is complete, and ambient temperature and humidity conditions are maintained at the levels indicated for Project when occupied for its intended use.

PART 2 - PRODUCTS

2.1 MANUFACTURERS

A. Source Limitations: Obtain each type of acoustical wood ceiling panel and its supporting suspension system from single source from single manufacturer.

2.2 PERFORMANCE REQUIREMENTS

A. Surface-Burning Characteristics: Comply with ASTM E 84; testing by a qualified testing agency. Identify products with appropriate markings of applicable testing agency.

1. Flame-Spread Index: Class C, 76-200 according to ASTM E 84.
2. Smoke-Developed Index: 450 or less.

2.3 ACOUSTICAL WOOD PANELS – SP #1

- A. Basis-of-Design Product: Subject to compliance with requirements, provide Armstrong; WOODWORKS Linear Veneered Planks or a comparable product by one of the following:
1. Decoustics Saint Gobain.
 2. Rulon International Inc.
 3. Architectural Surfaces, Inc.
- B. Ceiling Panel
1. Surface Texture: Smooth
 2. Composition: Wood
 3. Species/Finish: Grille Light Cherry
 4. Plank Size: 5 ¼" x 96" x ¾" thick
 5. Reveal: ¾"
 6. Sabin: N/A
 7. Edge Banding and Trim: To match face veneer
- C. Trim: Basis of Design: Armstrong Wood Works Edge Moldings and Trim.
1. End cap: Match slat height.
- D. Acoustic Infill Panels:
1. Provide Armstrong BioAcoustic Infill Panel.

2.4 METAL SUSPENSION SYSTEM

- A. Basis-of-Design Product: Subject to compliance with requirements, provide Armstrong; Heavy Duty Linear Carriers with Integral Clips Suspension System.
1. Color: Black

2.5 ACCESSORIES

- A. Attachment Devices: Size for five times the design load indicated in ASTM C 635/C 635M, Table 1, "Direct Hung," unless otherwise indicated. Comply with seismic design requirements.
- B. Wire Hangers, Braces, and Ties: Provide wires as follows:
1. Zinc-Coated, Carbon-Steel Wire: ASTM A 641/A 641M, Class 1 zinc coating, soft temper.
 2. Stainless-Steel Wire: ASTM A 580/A 580M, Type 304, nonmagnetic.
 3. Nickel-Copper-Alloy Wire: ASTM B 164, nickel-copper-alloy UNS No. N04400.

4. Size: Wire diameter sufficient for its stress at three times hanger design load (ASTM C 635/C 635M, Table 1, "Direct Hung") will be less than yield stress of wire, but not less than 0.106-inch diameter wire.
- C. Hanger Rods: Mild steel, zinc coated or protected with rust-inhibitive paint.
- D. Flat Hangers: Mild steel, zinc coated or protected with rust-inhibitive paint.
- E. Angle Hangers: Angles with legs not less than 7/8-inch wide; formed with 0.04-inch thick, galvanized-steel sheet complying with ASTM A 653/A 653M, G90 coating designation; with bolted connections and 5/16-inch diameter bolts.
- F. Hold-Down Clips: Manufacturer's standard hold-down.
- G. Impact Clips: Manufacturer's standard impact-clip system designed to absorb impact forces against acoustical panels.

PART 3 - EXECUTION

3.1 EXAMINATION

- A. Examine substrates, areas, and conditions, including structural framing to which acoustical panel ceilings attach or abut, with Installer present, for compliance with requirements specified in this and other Sections that affect ceiling installation and anchorage and with requirements for installation tolerances and other conditions affecting performance of acoustical panel ceilings.
- B. Examine acoustical panels before installation. Reject acoustical panels that are wet, moisture damaged, or mold damaged.
- C. Proceed with installation only after unsatisfactory conditions have been corrected.

3.2 PREPARATION

- A. Measure each ceiling area and establish layout of acoustical panels to balance border widths at opposite edges of each ceiling. Avoid using less-than-half-width panels at borders unless otherwise indicated, and comply with layout shown on reflected ceiling plans.
- B. Layout openings for penetrations centered on the penetrating items.

3.3 INSTALLATION

- A. Suspend ceiling hangers from building's structural members and as follows:
 1. Install hangers plumb and free from contact with insulation or other objects within ceiling plenum that are not part of supporting structure or of ceiling suspension system.

2. Splay hangers only where required and, if permitted with fire-resistance-rated ceilings, to miss obstructions; offset resulting horizontal forces by bracing, countersplaying, or other equally effective means.
 3. Where width of ducts and other construction within ceiling plenum produces hanger spacings that interfere with location of hangers at spacings required to support standard suspension-system members, install supplemental suspension members and hangers in form of trapezes or equivalent devices.
 4. Secure wire hangers to ceiling-suspension members and to supports above with a minimum of three tight turns. Connect hangers directly to structure or to inserts, eye screws, or other devices that are secure and appropriate for substrate and that will not deteriorate or otherwise fail due to age, corrosion, or elevated temperatures.
 5. Secure flat, angle, channel, and rod hangers to structure, including intermediate framing members, by attaching to inserts, eye screws, or other devices that are secure and appropriate for both the structure to which hangers are attached and the type of hanger involved. Install hangers in a manner that will not cause them to deteriorate or fail due to age, corrosion, or elevated temperatures.
 6. Do not support ceilings directly from permanent metal forms or floor deck. Fasten hangers to cast-in-place hanger inserts, postinstalled mechanical or adhesive anchors, or power-actuated fasteners that extend through forms into concrete.
 7. When steel framing does not permit installation of hanger wires at spacing required, install carrying channels or other supplemental support for attachment of hanger wires.
 8. Do not attach hangers to steel deck tabs.
 9. Do not attach hangers to steel roof deck. Attach hangers to structural members.
 10. Space hangers not more than 48 inches o.c. along each member supported directly from hangers unless otherwise indicated; provide hangers not more than 8 inches from ends of each member.
 11. Size supplemental suspension members and hangers to support ceiling loads within performance limits established by referenced standards.
- B. Secure bracing wires to ceiling suspension members and to supports with a minimum of four tight turns. Suspend bracing from building's structural members as required for hangers, without attaching to permanent metal forms, steel deck, or steel deck tabs. Fasten bracing wires into concrete with cast-in-place or postinstalled anchors.
- C. Install edge moldings and trim of type indicated at perimeter of acoustical ceiling area and where necessary to conceal edges of acoustical panels.
1. Apply acoustical sealant in a continuous ribbon concealed on back of vertical legs of moldings before they are installed.
 2. Screw attach moldings to substrate at intervals not more than 16 inches o.c. and not more than 3 inches from ends. Miter corners accurately and connect securely.
 3. Do not use exposed fasteners, including pop rivets, on moldings and trim.
- D. Install suspension-system runners so they are square and securely interlocked with one another. Remove and replace dented, bent, or kinked members.
- E. Install acoustical wood panels with undamaged edges and fit accurately into suspension-system runners and edge moldings. Scribe and cut panels at borders and penetrations to provide precise fit.
1. Arrange directionally patterned acoustical panels as follows:

- a. As indicated on Architectural Drawings.
2. For square-edged panels, install panels with edges fully hidden from view by flanges of suspension-system runners and moldings.
3. Paint cut edges of slats remaining exposed after installation; match color of exposed panel surfaces using coating recommended in writing for this purpose by panel manufacturer.
4. Protect lighting fixtures and air ducts according to requirements indicated for fire-resistance-rated assembly.

3.4 ERECTION TOLERANCES

- A. Suspended Ceilings: Install main and cross runners level to a tolerance of 1/8 inch in 12 feet non-cumulative.
- B. Moldings and Trim: Install moldings and trim to substrate and level with ceiling suspension system to a tolerance of 1/8 inch in 12 feet, non-cumulative.

3.5 CLEANING

- A. Clean exposed surfaces of acoustical panel ceilings, including trim, edge moldings, and suspension-system members. Comply with manufacturer's written instructions for cleaning and touchup of minor finish damage.
- B. Remove and replace ceiling components that cannot be successfully cleaned and repaired to permanently eliminate evidence of damage.

END OF SECTION 095126

SECTION 096513 - RESILIENT BASE AND ACCESSORIES

PART 1 - GENERAL

1.1 RELATED DOCUMENTS

- A. Drawings and general provisions of the Contract, including General and Supplementary Conditions and Division 01 Specification Sections, apply to this Section.

1.2 SUMMARY

- A. Section Includes:
 - 1. Profile resilient base.
 - 2. Standard resilient base.
 - 3. Resilient molding accessories.

1.3 ACTION SUBMITTALS

- A. Product Data: For each type of product.
- B. Samples: For each exposed product and for each color and texture specified, not less than 12 inches long. Samples shall be approved by designer prior to installation.
- C. Samples for Initial Selection: For each type of product indicated.
- D. Samples for Verification: For each type of product indicated and for each color, texture, and pattern required in manufacturer's standard-size Samples, but not less than 12 inches long.
- E. Product Schedule: For resilient base and accessory products. Use same designations indicated on Drawings.

1.4 MAINTENANCE MATERIAL SUBMITTALS

- A. Furnish extra materials that match products installed and that are packaged with protective covering for storage and identified with labels describing contents.
 - 1. Furnish not less than 10 linear feet for every 500 linear feet or fraction thereof, of each type, color, pattern, and size of resilient product installed.

1.5 QUALITY ASSURANCE

- A. Mockups: Build mockups to verify selections made under Sample submittals and to demonstrate aesthetic effects and set quality standards for materials and execution.

1. Coordinate mockups in this Section with mockups specified in other Sections.

1.6 DELIVERY, STORAGE, AND HANDLING

- A. Store resilient products and installation materials in dry spaces protected from the weather, with ambient temperatures maintained within range recommended by manufacturer, but not less than 50 deg F or more than 90 deg F.

1.7 FIELD CONDITIONS

- A. Maintain ambient temperatures within range recommended by manufacturer, but not less than 70 deg F or more than 95 deg F, in spaces to receive resilient products during the following time periods:
 1. 48 hours before installation.
 2. During installation.
 3. 48 hours after installation.
- B. After installation and until Final Acceptance, maintain ambient temperatures within range recommended by manufacturer, but not less than 55 deg F or more than 95 deg F.
- C. Install resilient products after other finishing operations, including painting, have been completed.

PART 2 - PRODUCTS

2.1 THERMOPLASTIC-RUBBER BASE [RBBS-1] (Profile Resilient Base)

- A. Basis of Design Product: Subject to compliance with requirements, provide Tarkett “Millwork Wall Base – Reveal MW-XX-F6” or comparable product by one of the following:
 1. Burke Mercer Flooring Products, Division of Burke Industries Inc.
 2. Flexco.
 3. Mannington
- B. Product Standard: ASTM F 1861, Type TP (rubber, thermoplastic).
 1. Group: I (solid, homogeneous).
- C. Thickness: 0.25 inch.
- D. Height: 6 inches.
- E. Colors: As indicated on drawings. Final selection by Architect from manufacturer’s full range colors.

2.2 THERMOSET-RUBBER BASE [RBBS-2] (Standard Resilient Base)

- A. Manufacturers: Subject to compliance with requirements, provide products by one of the following:
1. Johnsonite.
 2. Mannington
 3. Roppe Corporation, USA.
- B. Resilient Base Standard: ASTM F 1861.
1. Material Requirement: Type TS (rubber, vulcanized thermoset)
 2. Manufacturing Method: Group I (solid, homogeneous).
 3. Style: Cove (base with toe) or straight.
- C. Minimum Thickness: 0.125 inch.
1. Height: 4 inches.
 2. Lengths: Coils in manufacturer's standard length.
 3. Outside Corners: Preformed.
 4. Inside Corners: Miter cut or Preformed.
 5. Colors: As indicated in the Finish and Color Schedule or as selected by Architect from full range of industry colors.

2.3 RESILIENT MOLDING ACCESSORY

- A. Resilient Molding Accessory:
1. Manufacturers: Subject to compliance with requirements, provide products by one of the following:
 - a. Burke Mercer Flooring Products; Division of Burke Industries, Inc.
 - b. Johnsonite.
 - c. Roppe Corporation, USA.
- B. Description: Nosing for carpet, Reducer strips, Joiner for resilient tile and carpet Transition strips.
- C. Material: Rubber.
- D. Profile and Dimensions: As indicated in transition schedules. Where not indicated, provide manufacturer's standard rubber transition for the following applications:
1. Carpet to VCT: 1 to 1 ¼ inch wide sloped resilient rubber transition strip, routed on both edges to capture and conceal the exposed edges of the finished flooring. Similar to Johnsonite Wheeled Traffic transition CTA-XX-D
 2. Carpet to Concrete, hardwood, or lower elevation floor finish: 2½ wide flexible rubber reducer strip to transition from up to 3/8" glue down carpet to top of adjacent surface. Similar to Johnsonite Wheeled Traffic transitions CTA-XX-P.
 3. Indicated transition details supercede generic transitions specified here.

- E. Colors and Patterns: As indicated on the Finish and Color Schedule or as selected by Architect from full range of industry colors.

2.4 INSTALLATION MATERIALS

- A. Trowelable Leveling and Patching Compounds: Latex-modified, portland cement based or blended hydraulic-cement-based formulation provided or approved by resilient-product manufacturer for applications indicated.
- B. Adhesives: Water-resistant type recommended by resilient-product manufacturer for resilient products and substrate conditions indicated.
- C. Metal Edge Strips: Extruded aluminum with mill finish of width shown, of height required to protect exposed edges of flooring, and in maximum available lengths to minimize running joints.
- D. Floor Polish: Provide protective, liquid floor-polish products recommended by resilient stair-tread manufacturer.

PART 3 - EXECUTION

3.1 EXAMINATION

- A. Examine substrates, with Installer present, for compliance with requirements for maximum moisture content and other conditions affecting performance of the Work.
 - 1. Verify that finishes of substrates comply with tolerances and other requirements specified in other Sections and that substrates are free of cracks, ridges, depressions, scale, and foreign deposits that might interfere with adhesion of resilient products.
- B. Proceed with installation only after unsatisfactory conditions have been corrected.
 - 1. Installation of resilient products indicates acceptance of surfaces and conditions.

3.2 PREPARATION

- A. Prepare substrates according to manufacturer's written instructions to ensure adhesion of resilient products.
- B. Concrete Substrates for Resilient Stair Accessories: Prepare horizontal surfaces according to ASTM F 710.
 - 1. Verify that substrates are dry and free of curing compounds, sealers, and hardeners.
 - 2. Remove substrate coatings and other substances that are incompatible with adhesives and that contain soap, wax, oil, or silicone, using mechanical methods recommended by manufacturer. Do not use solvents.

3. Alkalinity and Adhesion Testing: Perform tests recommended by manufacturer. Proceed with installation only after substrate alkalinity falls within range on pH scale recommended by manufacturer in writing.
 4. Moisture Testing: Perform tests recommended by manufacturer. Proceed with installation only after substrates pass testing according to manufacturer's written recommendations.
- C. Fill cracks, holes, and depressions in substrates with trowelable leveling and patching compound; remove bumps and ridges to produce a uniform and smooth substrate.
 - D. Do not install resilient products until they are the same temperature as the space where they are to be installed.
 1. At least 48 hours in advance of installation, move resilient products and installation materials into spaces where they will be installed.
 - E. Immediately before installation, sweep and vacuum clean substrates to be covered by resilient products.

3.3 RESILIENT BASE INSTALLATION

- A. Comply with manufacturer's written instructions for installing resilient base.
- B. Apply resilient base to walls, columns, pilasters, casework and cabinets in toe spaces, and other permanent fixtures in rooms and areas where base is required.
- C. Install resilient base in lengths as long as practical without gaps at seams and with tops of adjacent pieces aligned.
- D. Tightly adhere resilient base to substrate throughout length of each piece, with base in continuous contact with horizontal and vertical substrates.
- E. Do not stretch resilient base during installation.
- F. On masonry surfaces or other similar irregular substrates, fill voids along top edge of resilient base with manufacturer's recommended adhesive filler material.
- G. Preformed Corners: Install preformed corners before installing straight pieces.

3.4 RESILIENT ACCESSORY INSTALLATION

- A. Comply with manufacturer's written instructions for installing resilient accessories.
- B. Resilient Molding Accessories: Butt to adjacent materials and tightly adhere to substrates throughout length of each piece. Install reducer strips at edges of floor covering that would otherwise be exposed.

3.5 CLEANING AND PROTECTION

- A. Comply with manufacturer's written instructions for cleaning and protecting resilient products.

- B. Perform the following operations immediately after completing resilient-product installation:
 - 1. Remove adhesive and other blemishes from exposed surfaces.
 - 2. Sweep and vacuum horizontal surfaces thoroughly.
 - 3. Damp-mop horizontal surfaces to remove marks and soil.
- C. Protect resilient products from mars, marks, indentations, and other damage from construction operations and placement of equipment and fixtures during remainder of construction period.
- D. Floor Polish: Remove soil, visible adhesive, and surface blemishes from resilient stair treads before applying liquid floor polish.
 - 1. Apply **one** coat.
- E. Cover resilient products subject to wear and foot traffic until Final Acceptance.

END OF SECTION 096513

SECTION 096519 - RESILIENT TILE FLOORING (QUARTZ)

PART 1 - GENERAL

1.1 RELATED DOCUMENTS

- A. Drawings and general provisions of the Contract, including General and Supplementary Conditions and Division 01 Specification Sections, apply to this Section.

1.2 SUMMARY

- A. Section Includes:
 - 1. Premium vinyl floor tile.

1.3 ACTION SUBMITTALS

- A. Product Data: For each type of product.
- B. Shop Drawings: For each type of floor tile. Include floor tile layouts, edges, columns, doorways, enclosing partitions, built-in furniture, cabinets, and cutouts.
 - 1. Show details of special patterns.
- C. Samples: Full-size units of each color and pattern of floor tile required.
- D. Samples for Initial Selection: For each type of floor tile indicated.
- E. Samples for Verification: Full-size units of each color and pattern of floor tile required.
- F. Product Schedule: For floor tile. Use same designations indicated on Finish Schedule on Drawings.

1.4 INFORMATIONAL SUBMITTALS

- A. Qualification Data: For Installer.

1.5 CLOSEOUT SUBMITTALS

- A. Maintenance Data: For each type of floor tile to include in maintenance manuals.

1.6 MAINTENANCE MATERIAL SUBMITTALS

- A. Furnish extra materials that match products installed and that are packaged with protective covering for storage and identified with labels describing contents.
 - 1. Floor Tile: Furnish one box for every 50 boxes or fraction thereof, of each type, color, and pattern of floor tile installed.

1.7 QUALITY ASSURANCE

- A. Installer Qualifications: A qualified installer who employs workers for this Project who are competent in techniques required by manufacturer for floor tile installation and seaming method indicated.
 - 1. Engage an installer who employs workers for this Project who are trained or certified by floor tile manufacturer for installation techniques required.
- B. Fire-Test-Response Characteristics: As determined by testing identical products according to ASTM E 648 or NFPA 253 by a qualified testing agency.
 - 1. Critical Radiant Flux Classification: Class I, not less than 0.45 W/sq. cm.

1.8 DELIVERY, STORAGE, AND HANDLING

- A. Store floor tile and installation materials in dry spaces protected from the weather, with ambient temperatures maintained within range recommended by manufacturer, but not less than 50 deg F or more than 90 deg F. Store floor tiles on flat surfaces.

1.9 FIELD CONDITIONS

- A. Maintain ambient temperatures within range recommended by manufacturer, but not less than 60 deg F or more than 80 deg F, in spaces to receive floor tile during the following time periods:
 - 1. 48 hours before installation.
 - 2. During installation.
 - 3. 48 hours after installation.
- B. After installation and until Final Acceptance, maintain ambient temperatures within range recommended by manufacturer, but not less than 65 deg F or more than 75 deg F.
- C. Close spaces to traffic during floor tile installation.
- D. Close spaces to traffic for 48 hours after floor tile installation.
- E. Install floor tile after other finishing operations, including painting, have been completed.

PART 2 - PRODUCTS

2.1 PREMIUM QUARTZ COMPOSITION FLOOR TILE (QCT)

- A. Basis of Design Product: Subject to compliance with requirements, provide “Quartz Mosaic” series as manufactured by KAHRS International, Alta Monte Springs, FL, or comparable products by one of the following:
 - 1. Altro Eastern, Wilmington, MA.
 - 2. American Biltrite, Sherbrooke, Quebec, Canada.
- B. Color Fastness: EN 150 105-B02 ≥ 6
- C. Wear and scratch resistance: EN 660-2: Class T $\leq 2.0\text{mm}^3$
- D. Thickness: 2.0mm.
- E. Size: 24 by 12 inches.
- F. Colors and Patterns:
 - 1. As selected by Architect from manufacturer’s full range.

2.2 INSTALLATION MATERIALS

- A. Trowelable Leveling and Patching Compounds: Latex-modified, portland cement based or blended hydraulic-cement-based formulation provided or approved by floor tile manufacturer for applications indicated.
- B. Adhesives: Water-resistant type recommended by floor tile and adhesive manufacturers to suit floor tile and substrate conditions indicated.
 - 1. Use adhesives that comply with the following limits for VOC content when calculated according to 40 CFR 59, Subpart D (EPA Method 24):
 - a. Vinyl Tile Adhesives: Not more than 50 g/L.

PART 3 - EXECUTION

3.1 EXAMINATION

- A. Examine substrates, with Installer present, for compliance with requirements for maximum moisture content and other conditions affecting performance of the Work.
 - 1. Verify that finishes of substrates comply with tolerances and other requirements specified in other Sections and that substrates are free of cracks, ridges, depressions, scale, and foreign deposits that might interfere with adhesion of floor tile.

- B. Proceed with installation only after unsatisfactory conditions have been corrected.

3.2 PREPARATION

- A. Prepare substrates according to floor tile manufacturer's written instructions to ensure adhesion of resilient products.
- B. Concrete Substrates: Prepare according to ASTM F 710.
 - 1. Verify that substrates are dry and free of curing compounds, sealers, and hardeners.
 - 2. Remove substrate coatings and other substances that are incompatible with adhesives and that contain soap, wax, oil, or silicone, using mechanical methods recommended by floor tile manufacturer. Do not use solvents.
 - 3. Alkalinity and Adhesion Testing: Perform tests recommended by floor tile manufacturer. Proceed with installation only after substrate alkalinity falls within range on pH scale recommended by manufacturer in writing.
 - 4. Moisture Testing: Perform tests recommended by floor tile manufacturer. Proceed with installation only after substrates pass testing according to floor tile manufacturer's written recommendations.
- C. Fill cracks, holes, and depressions in substrates with trowelable leveling and patching compound; remove bumps and ridges to produce a uniform and smooth substrate.
- D. Do not install floor tiles until they are the same temperature as the space where they are to be installed.
 - 1. At least 48 hours in advance of installation, move resilient floor tile and installation materials into spaces where they will be installed.
- E. Immediately before installation, sweep and vacuum clean substrates to be covered by resilient floor tile.

3.3 FLOOR TILE INSTALLATION

- A. Comply with manufacturer's written instructions for installing floor tile.
 - 1. Coordinate installation requirements with tile manufacturer's warranty requirements.
 - 2. Verify acceptable underlayment and patching compounds with tile manufacturer installation requirements.
- B. Lay out floor tiles from center marks established with principal walls, discounting minor offsets, so tiles at opposite edges of room are of equal width. Adjust as necessary to avoid using cut widths that equal less than one-half tile at perimeter.
 - 1. Lay tiles square with room axis unless otherwise indicated.
- C. Match floor tiles for color and pattern by selecting tiles from cartons in the same sequence as manufactured and packaged, if so numbered. Discard broken, cracked, chipped, or deformed tiles.

1. Lay tiles with grain direction and pattern of colors and sizes indicated in Finish Schedules. Where not indicated, rotate tiles $\frac{1}{4}$ turn.
- D. Scribe, cut, and fit floor tiles to butt neatly and tightly to vertical surfaces and permanent fixtures including built-in furniture, cabinets, pipes, outlets, and door frames.
- E. Extend floor tiles into toe spaces, door reveals, closets, and similar openings. Extend floor tiles to center of door openings.
- F. Maintain reference markers, holes, and openings that are in place or marked for future cutting by repeating on floor tiles as marked on substrates. Use chalk or other nonpermanent marking device.
- G. Adhere floor tiles to flooring substrates using a full spread of adhesive applied to substrate to produce a completed installation without open cracks, voids, raising and puckering at joints, telegraphing of adhesive spreader marks, and other surface imperfections.

3.4 CLEANING AND PROTECTION

- A. Comply with manufacturer's written instructions for cleaning and protecting floor tile.
- B. Perform the following operations immediately after completing floor tile installation:
 1. Remove adhesive and other blemishes from exposed surfaces.
 2. Sweep and vacuum surfaces thoroughly.
 3. Damp-mop surfaces to remove marks and soil.
- C. Protect floor tile from mars, marks, indentations, and other damage from construction operations and placement of equipment and fixtures during remainder of construction period.
- D. Cover floor tile until Final Acceptance.

END OF SECTION 096519

SECTION 096520 – LUXURY VINYL TILE FLOORING

PART 1 - GENERAL

1.1 RELATED DOCUMENTS

- A. Drawings and general provisions of the Contract, including General and Supplementary Conditions and Division 01 Specification Sections, apply to this Section.

1.2 SUMMARY

- A. Section Includes:

- 1. Luxury vinyl tile.

1.3 ACTION SUBMITTALS

- A. Product Data: For each type of product.
- B. Shop Drawings: For each type of floor tile. Include floor tile layouts, edges, columns, doorways, enclosing partitions, built-in furniture, cabinets, and cutouts.
 - 1. Show details of special patterns.
- C. Samples: Full-size units of each color and pattern of floor tile required.
- D. Samples for Initial Selection: For each type of floor tile indicated.
- E. Samples for Verification: Full-size units of each color and pattern of floor tile required.
- F. Product Schedule: For floor tile. Use same designations indicated on Finish Schedule on Drawings.

1.4 CLOSEOUT SUBMITTALS

- A. Maintenance Data: For each type of floor tile to include in maintenance manuals.

1.5 MAINTENANCE MATERIAL SUBMITTALS

- A. Furnish extra materials that match products installed and that are packaged with protective covering for storage and identified with labels describing contents.
 - 1. Floor Tile: Furnish one box for every 50 boxes or fraction thereof, of each type, color, and pattern of floor tile installed.

1.6 QUALITY ASSURANCE

- A. Installer Qualifications: A qualified installer who employs workers for this Project who are competent in techniques required by manufacturer for floor tile installation and seaming method indicated.
 - 1. Engage an installer who employs workers for this Project who are trained or certified by floor tile manufacturer for installation techniques required.
- B. Mockups: Build mockups to verify selections made under Sample submittals and to demonstrate aesthetic effects and set quality standards for materials and execution.
 - 1. Build mockups for floor tile including resilient base and accessories.
 - a. Size: Minimum 100 sq. ft. for each type, color, and pattern in locations directed by Architect.
 - 2. Approval of mockups does not constitute approval of deviations from the Contract Documents contained in mockups unless Architect specifically approves such deviations in writing.
 - 3. Subject to compliance with requirements, approved mockups may become part of the completed Work if undisturbed at time of Substantial Completion.

1.7 DELIVERY, STORAGE, AND HANDLING

- A. Store floor tile and installation materials in dry spaces protected from the weather, with ambient temperatures maintained within range recommended by manufacturer, but not less than 50 deg F or more than 90 deg F. Store floor tiles on flat surfaces.

1.8 FIELD CONDITIONS

- A. Maintain ambient temperatures within range recommended by manufacturer, but not less than 60 deg F or more than 80 deg F, in spaces to receive floor tile during the following time periods:
 - 1. 48 hours before installation.
 - 2. During installation.
 - 3. 48 hours after installation.
- B. After installation and until Final Acceptance, maintain ambient temperatures within range recommended by manufacturer, but not less than 65 deg F or more than 75 deg F.
- C. Close spaces to traffic during floor tile installation.
- D. Close spaces to traffic for 48 hours after floor tile installation.
- E. Install floor tile after other finishing operations, including painting, have been completed.

PART 2 - PRODUCTS

2.1 LUXURY VINYL FLOOR TILE [LVT-1]

- A. Basis of Design Product: Subject to compliance with requirements, provide 'Van Gogh – gluedown by Karndean Design Flooring' or comparable product by one of the following:
 - 1. Milliken.
 - 2. Mohawk Group.
- B. Tile Standard: ASTM F 1700, Class II, Type B.
- C. Thickness: To be determined, but not less than 3 mm, wear layer is 20 mil.
- D. Size: 48" x 7".
- E. Colors, Patterns, Finish:
 - 1. LVT: Color to be determined from manufacturer's full range. Lay in 1/3 offset.
- F. Commercial Warranty: 15 years.

2.2 INSTALLATION MATERIALS

- A. Trowelable Leveling and Patching Compounds: Latex-modified, portland cement based or blended hydraulic-cement-based formulation provided or approved by floor tile manufacturer for applications indicated.
- B. Adhesives: Water-resistant type recommended by floor tile and adhesive manufacturers to suit floor tile and substrate conditions indicated.
- C. Floor Polish: Provide protective, liquid floor-polish products recommended by floor tile manufacturer.

PART 3 - EXECUTION

3.1 EXAMINATION

- A. Examine substrates, with Installer present, for compliance with requirements for maximum moisture content and other conditions affecting performance of the Work.
 - 1. Verify that finishes of substrates comply with tolerances and other requirements specified in other Sections and that substrates are free of cracks, ridges, depressions, scale, and foreign deposits that might interfere with adhesion of floor tile.
- B. Proceed with installation only after unsatisfactory conditions have been corrected.

3.2 PREPARATION

- A. Prepare substrates according to floor tile manufacturer's written instructions to ensure adhesion of resilient products.
- B. Concrete Substrates: Prepare according to ASTM F 710.
 - 1. Verify that substrates are dry and free of curing compounds, sealers, and hardeners.
 - 2. Remove substrate coatings and other substances that are incompatible with adhesives and that contain soap, wax, oil, or silicone, using mechanical methods recommended by floor tile manufacturer. Do not use solvents.
 - 3. Alkalinity and Adhesion Testing: Perform tests recommended by floor tile manufacturer. Proceed with installation only after substrate alkalinity falls within range on pH scale recommended by manufacturer in writing.
 - 4. Moisture Testing: Perform tests recommended by floor tile manufacturer. Proceed with installation only after substrates pass testing according to floor tile manufacturer's written recommendations.
- C. Fill cracks, holes, and depressions in substrates with trowelable leveling and patching compound; remove bumps and ridges to produce a uniform and smooth substrate.
- D. Do not install floor tiles until they are the same temperature as the space where they are to be installed.
 - 1. At least 48 hours in advance of installation, move resilient floor tile and installation materials into spaces where they will be installed.
- E. Immediately before installation, sweep and vacuum clean substrates to be covered by resilient floor tile.

3.3 FLOOR TILE INSTALLATION

- A. Comply with manufacturer's written instructions for installing floor tile.
 - 1. Coordinate installation requirements with tile manufacturer's warranty requirements.
 - 2. Verify acceptable underlayment and patching compounds with tile manufacturer installation requirements.
- B. Lay out floor tiles from center marks established with principal walls, discounting minor offsets, so tiles at opposite edges of room are of equal width. Adjust as necessary to avoid using cut widths that equal less than one-half tile at perimeter.
 - 1. Lay tiles square with room axis unless otherwise indicated.
- C. Match floor tiles for color and pattern by selecting tiles from cartons in the same sequence as manufactured and packaged, if so numbered. Discard broken, cracked, chipped, or deformed tiles.
 - 1. Lay tiles with grain direction and pattern of colors and sizes indicated in Finish Schedules. Where not indicated, rotate tiles $\frac{1}{4}$ turn.

- D. Scribe, cut, and fit floor tiles to butt neatly and tightly to vertical surfaces and permanent fixtures including built-in furniture, cabinets, pipes, outlets, and door frames.
- E. Extend floor tiles into toe spaces, door reveals, closets, and similar openings. Extend floor tiles to center of door openings.
- F. Maintain reference markers, holes, and openings that are in place or marked for future cutting by repeating on floor tiles as marked on substrates. Use chalk or other nonpermanent marking device.
- G. Adhere floor tiles to flooring substrates using a full spread of adhesive applied to substrate to produce a completed installation without open cracks, voids, raising and puckering at joints, telegraphing of adhesive spreader marks, and other surface imperfections.

3.4 CLEANING AND PROTECTION

- A. Comply with manufacturer's written instructions for cleaning and protecting floor tile.
- B. Perform the following operations immediately after completing floor tile installation:
 - 1. Remove adhesive and other blemishes from exposed surfaces.
 - 2. Sweep and vacuum surfaces thoroughly.
 - 3. Damp-mop surfaces to remove marks and soil.
- C. Protect floor tile from mars, marks, indentations, and other damage from construction operations and placement of equipment and fixtures during remainder of construction period.
- D. Floor Polish: Remove soil, adhesive, and blemishes from floor tile surfaces before applying liquid floor polish.
 - 1. Apply two coats.
- E. Cover floor tile until Final Acceptance.

END OF SECTION 096519

SECTION 096623 - RESINOUS MATRIX TERRAZZO FLOORING (INCLUDED IN ALTERNATE #3)

PART 1 - GENERAL

1.1 RELATED DOCUMENTS

- A. Drawings and general provisions of the Contract, including General and Supplementary Conditions and Division 01 Specification Sections, apply to this Section.

1.2 SUMMARY

- A. Section Includes:
 - 1. Precast, epoxy-resin terrazzo stair units.
 - a. Installed over existing substate.
 - 2. Pre-cast, epoxy-resin terrazzo tile units.
 - a. Installed over existing substate.
 - 3. Related accessories.
- B. Related Requirements
 - 1. Division 07 Section "Joint Sealants".

1.3 PREINSTALLATION MEETINGS

- A. Preinstallation Conference: Conduct conference at Project site.
 - 1. Review methods and procedures related to terrazzo including, but not limited to, the following:
 - a. Inspect and discuss condition of substrate and other preparatory work performed by other trades.
 - b. Review and finalize construction schedule and verify availability of materials, Installer's personnel, equipment, and facilities needed to make progress and avoid delays.
 - c. Review special terrazzo designs and patterns.
 - d. Review dust control procedures.

1.4 ACTION SUBMITTALS

- A. Product Data: Manufacturer's product data for each type of terrazzo and accessory. System will be evaluated on the basis of standards. For tests not listed in published data, manufacturer shall supply missing data according to standard referenced.
 - 1. Physical properties.
 - 2. Performance properties.
 - 3. Specified tests.
 - 4. Material Safety Data Sheet.
 - 5. Manufacturer's standard warranty.

- B. Shop Drawings: Include terrazzo installation requirements. Include plans, elevations, sections, component details, and attachments to other work. Show layout of the following:
 - 1. Control and Expansion joint strips.
 - 2. Accessory strips.
 - 3. Abrasive strips.
 - 4. Stair treads, risers, and landings.
 - 5. Precast terrazzo jointing and edge configurations including anchorage details.
 - 6. Terrazzo patterns.

- C. Samples for Initial Selection: Manufacturer's color plates showing the full range of colors and patterns available for each terrazzo type indicated for colors and patterns indicated in Finish and Color Schedules.

- D. Samples for Verification: For each type, material, color, and pattern of terrazzo and accessory required showing the full range of color, texture, and pattern variations expected. Label each terrazzo sample to identify manufacturer's matrix color and aggregate types, sizes, and proportions. Prepare Samples of same thickness and from same material to be used for the Work, in size indicated below:
 - 1. Stair Treads: 12" (304.8-mm) wide sample of combination tread and riser with cast-in nosing.
 - 2. Precast Terrazzo: 6-inch- square Samples.
 - 3. Accessories: 6-inch- (150-mm-) long Samples of each exposed strip item required.

- E. Material Test Reports: For moisture and/or relative humidity of substrate.

- F. Performance Requirements
 - 1. Compressive Strength: > 10,000 p.s.i.
 - 2. Flexural Strength: > 3,000 p.s.i.
 - 3. Suppliers provide certification demonstrating terrazzo materials meet specification requirements

1.5 CLOSEOUT SUBMITTALS

- A. Maintenance Data: Submit copies of NTMA maintenance recommendations and manufacturer's instructions in accordance with Division 01 Section "Closeout Procedures."

1.6 QUALITY ASSURANCE

A. Installer Qualifications:

1. Engage an installer who is a contractor member of NTMA.
2. Engage an installer who is certified in writing by terrazzo manufacturer as qualified to install manufacturer's products.
3. Engage a terrazzo contractor with at least five (5) years of satisfactory experience in installation of epoxy terrazzo. Terrazzo contractor shall demonstrate experience during last five (5) years of at least (5) projects of comparable scope and complexity of at least 50 percent of the total square footage of this project.

B. Source Limitations: Obtain primary terrazzo materials from single source from single manufacturer. Provide secondary materials including patching and fill material, joint sealant, and repair materials of type and from source recommended by manufacturer of primary materials.

C. Source Limitations for Aggregates: Obtain each color, grade, type, and variety of granular materials from single source with resources to provide materials of consistent quality in appearance and physical properties.

D. Mockups: Build mockups to verify selections made under Sample submittals and to demonstrate aesthetic effects and set quality standards for materials and execution.

1. Build mockups for terrazzo including accessories.
 - a. Include first two stair treads in location directed by Architect.
2. Approval of mockups does not constitute approval of deviations from the Contract Documents contained in mockups unless Architect specifically approves such deviations in writing.
3. Approved mockups may become part of the completed Work if undisturbed at time of Final Acceptance.

1.7 DELIVERY, STORAGE, AND HANDLING

A. Deliver materials to Project site in supplier's original wrappings and containers, labeled with source's or manufacturer's name, material or product brand name, and lot number if any.

B. Store materials in their original, undamaged packages and containers, inside a well-ventilated area protected from weather, moisture, soiling, extreme temperatures, and humidity.

1. Storage temperatures should be between 60°F to 80°F.
2. If any damage occurs, report immediately. Bill of lading should note all damages to the product. Picture identification of damages attached.

1.8 FIELD CONDITIONS

- A. Environmental Limitations: Comply with manufacturer's written instructions for substrate temperature, ambient temperature, moisture, ventilation, and other conditions affecting terrazzo installation.
 - 1. Acceptable Substrates:
 - a. Level tolerance: Concrete sub-floor shall be level with a maximum variation from level of 1/4" in 10 feet. Any irregularity of the surface requiring patching and/or leveling shall be done epoxy modified cement and selected aggregates as recommended by epoxy flooring manufacturer.
- B. Field Measurements: Verify actual dimensions of construction contiguous with precast terrazzo by field measurements before fabrication.
- C. Provide permanent lighting or, if permanent lighting is not in place, simulate permanent lighting conditions during terrazzo installation.
- D. Close spaces to traffic during terrazzo application and for not less than 24 hours after application unless manufacturer recommends a longer period.
- E. Control and collect water and dust produced by grinding operations. Protect adjacent construction from detrimental effects of grinding operations.

PART 2 - PRODUCTS

2.1 PERFORMANCE REQUIREMENTS

- A. NTMA Standards: Comply with NTMA's "Terrazzo Specifications and Design Guide" and with written recommendations for terrazzo type indicated unless more stringent requirements are specified.
- B. FloorScore Compliance: Terrazzo floors shall comply with requirements of FloorScore Standard.
- C. Slip and Skid Resistance (Coefficient of Friction, COF): Terrazzo walking surfaces shall conform to the following criteria:
 - 1. COF, Measured by the James Machine (ASTM D 2047), for laboratory testing of product samples:
 - a. Level Surfaces with Polished Finish: 0.60, minimum.
 - 2. COF, Measured Using a Portable Inclineable Articulated Strut Slip Tester (ASTM F 1677), for in-situ testing of installed products:
 - a. Level Surfaces with Polished Finish: 0.60, minimum (dry and wet).

3. Reference Standards:
 - a. ASTM C 1028 - Standard Test Method for Determining the Static Coefficient of Friction of Ceramic Tile and Other Like Surfaces by the Horizontal Dynamometer Pull-Meter Method; 1996.
 - b. ASTM D 2047 - Standard Test Method for Static Coefficient of Friction of Polish-Coated Floor Surfaces as Measured by the James Machine; 1999.

2.2 PRECAST EPOXY-RESIN TERRAZZO

- A. General: Comply with NTMA's written recommendations for fabricating precast terrazzo units in sizes and profiles indicated. Reinforce units as required by unit sizes, profiles, and thicknesses and as recommended by manufacturer.
- B. Manufacturer: Comply with NTMA's 'Terrazzo Specifications and Design Guide' and manufacturer's written instructions.
 1. Basis of Design Product: Terrazzo Brand Products – Concord Terrazzo Company – Tread and Riser Combo – Structure Supported and Terrazzo Tiles. Subject to compliance with requirements, comparable products may be provided by one of the following:
 - a. Terrazzo Brand Products – Concord Terrazzo Company.
 - b. Precast Terrazzo Enterprises, Inc.
 - c. Angelozzi Terrazzo .
 - d. WAUSAU Tile.
- C. Materials
 1. Epoxy Resin
 2. Aggregates: All aggregates to meet ASTM C-33 specifications, cleaned and properly graded to size. Aggregate shall be blended to meet individual project requirements.
 3. Marble chips, size to conform NTMA gradation standards.
 4. Abrasive Inserts: Consist of silicon carbide and black epoxy. Three lines. – See drawings.
 5. Caulks and Sealants
 - a. Urethane or Polyurethane Sealant
 - b. Architect's color selection based from standard color pallet.
 6. Cleaner
 - a. Liquid neutral chemical cleaner, with pH factor between 7 and 8, of formulation recommended by sealer manufacture for type of precast terrazzo used and complying with NTMA requirements.
 7. Sealer
 - a. Sealers should be colorless, slip and stain-resistant with a pH level between 7 and 8. Sealer does not affect color or physical properties of precast terrazzo surfaces. Flash point (ASTM D56): minimum 80-degree Fahrenheit

D. Manufactured Units

1. Sizing Tolerances

- a. All manufactured units to conform to shop drawings with 1/16” tolerance in dimension.

2. Precast Surfaces and Edges:

- a. All exposed edges to be ground and polished with a minimum of 1/16” bevel.
- b. All finished surfaces are ground and polished. Surfaces to be free of pin holes and show uniformity in matrix and aggregate.
- c. All precast finishes to be applied with a sealer approved by manufacturer.

2.3 STRIP MATERIALS

A. Thin-Set Divider Strips: L-type angle, 3/8 inch (6.4 mm) deep.

1. Material: Aluminum.
2. Top Width: 1/8 inch (3.2 mm).

B. Accessory Strips: Match divider-strip width, material, and color unless otherwise indicated. Use the following types of accessory strips as required to provide a complete installation:

1. Base-bead strips for exposed top edge of terrazzo base.
2. Edge-bead strips for exposed edges of terrazzo.

C. Abrasive Strips: Three-line abrasive inserts at nosings. Silicon carbide or aluminum oxide, or combination of both, in epoxy-resin binder and set in channel.

1. Width: 1/2 inch (12.7 mm).
2. Depth: As required by terrazzo thickness.
3. Length: 4 inches (100 mm) less than stair width.
4. Color: As selected by Architect from full range of industry colors.

2.4 MISCELLANEOUS ACCESSORIES

A. Strip Adhesive: Epoxy-resin adhesive recommended by adhesive manufacturer for this use.

1. Adhesives shall have a VOC content of 70 g/L or less when calculated according to 40 CFR 59, Subpart D (EPA Method 24).

PART 3 – EXECUTION

3.1 EXAMINATION

A. Examine substrates and areas, with Installer present, for compliance with requirements for installation tolerances and other conditions affecting performance of the Work.

- B. Proceed with installation only after unsatisfactory conditions, including levelness tolerances, have been corrected.
- C. Verify the use of a Moisture Vapor Retarding Primer and Crack Isolation Membranes as necessary. Identify required amounts and coordinate with quantities provided in allowances. Submit written assessment and calculations.

3.2 PREPARATION

- A. Clean substrates of substances, including oil, grease, and curing compounds, that might impair bond. Provide clean, dry, and neutral substrate for terrazzo application.
- B. Concrete Slabs:
 - 1. Provide sound concrete surfaces free of laitance, glaze, efflorescence, curing compounds, form-release agents, dust, dirt, grease, oil, and other contaminants incompatible with terrazzo.

3.3 PRECAST TERRAZZO INSTALLATION

- A. Install precast terrazzo units using method recommended by NTMA and manufacturer unless otherwise indicated.
- B. Do not install units that are chipped, cracked, discolored, or not properly finished.
- C. Seal joints between units with joint compound matching precast terrazzo matrix.
- D. Setting of Precast
 - 1. Setting methods to vary by product. Refer to approved shop drawings to set accurately. Refer to material manufacturer on proper bonding of all materials.
 - 2. Setting Methods
 - a. Cement based. Contact selected manufacturer as recommended or specified. Setting materials can change without notice.
 - b. Epoxy based. Contact selected manufacturer as recommended or specified. Setting materials can change without notice.
 - 3. All thinset materials, whether cement or epoxy based, will require a full setting bed to be applied to all appropriate surfaces of the precast terrazzo, vertical and horizontal, where contact is made with the substrate or structural base.
 - 4. Alignment of precast should be straight and true to all dimensions. It may not vary more than 1/8" in length, height or width.
 - 5. If required, install anchors shown in detail.
 - 6. Fill joints in between caulk or as specified.
 - a. Joint width should not exceed 3/8" at adjacent surfaces.

3.4 REPAIR

- A. Cut out and replace terrazzo areas that evidence lack of bond with substrate. Cut out terrazzo areas in panels defined by strips and replace to match adjacent terrazzo, or repair panels according to NTMA's written recommendations, as approved by Architect.

3.5 CLEANING AND PROTECTION

A. Cleaning:

1. Remove grinding dust from installation and adjacent areas.
2. Wash surfaces with cleaner according to NTMA's written recommendations and manufacturer's written instructions; rinse surfaces with water and allow them to dry thoroughly.

B. Sealing:

1. All precast finishes to be applied with a sealer approved by the manufacturer.

C. Protection: Provide final protection and maintain conditions, in a manner acceptable to Installer, that ensure that terrazzo is without damage or deterioration at time of Final Acceptance.

END OF SECTION 096623

SECTION 096813 - TILE CARPETING

PART 1 - GENERAL

1.1 RELATED DOCUMENTS

- A. Drawings and general provisions of the Contract, including General and Supplementary Conditions and Division 01 Specification Sections, apply to this Section.

1.2 SUMMARY

- A. Section includes modular carpet tile.
- B. Related Sections include the following:
 - 1. Division 09 Section "Resilient Wall Base and Accessories and Resilient Tile Flooring" for resilient wall base and accessories installed with carpet tile.

1.3 SUBMITTALS

- A. Product Data: For each type of product indicated. Include manufacturer's written data on physical characteristics, durability, and fade resistance. Include installation recommendations for each type of substrate.
- B. Shop Drawings: Show the following:
 - 1. Carpet tile type, color, and dye lot.
 - 2. Type of subfloor.
 - 3. Type of installation.
 - 4. Pattern of installation.
 - 5. Pattern type, location, and direction.
 - 6. Pile direction.
 - 7. Type, color, and location of insets and borders.
 - 8. Type, color, and location of edge, transition, and other accessory strips.
 - 9. Transition details to other flooring materials.
- C. Samples: For each of the following products and for each color and texture required. Label each Sample with manufacturer's name, material description, color, pattern, and designation indicated on Drawings and in schedules.
 - 1. Carpet Tile: Full-size Sample.
 - 2. Exposed Edge, Transition, and other Accessory Stripping: 12-inch- long Samples.
- D. Product Schedule: For carpet tile. Use same designations indicated on Drawings.
- E. Qualification Data: For Installer.

- F. Product Test Reports: Based on evaluation of comprehensive tests performed by a qualified testing agency.
- G. Maintenance Data: For carpet tiles to include in maintenance manuals. Include the following:
 - 1. Methods for maintaining carpet tile, including cleaning and stain-removal products and procedures and manufacturer's recommended maintenance schedule.
 - 2. Precautions for cleaning materials and methods that could be detrimental to carpet tile.
- H. Warranty: Special warranty specified in this Section.

1.4 QUALITY ASSURANCE

- A. Installer Qualifications: An experienced installer who is certified by the Floor Covering Installation Board or who can demonstrate compliance with its certification program requirements.
- B. Fire-Test-Response Characteristics: Provide products with the critical radiant flux classification indicated in Part 2, as determined by testing identical products per ASTM E 648 by an independent testing and inspecting agency acceptable to authorities having jurisdiction.
- C. Mockups: Before installing carpet tile, build mockups to verify selections made under sample submittals and to demonstrate aesthetic effects and set quality standards for materials and execution.
 - 1. Approved mockups may become part of the completed Work if undamaged at time of Final Acceptance.
- D. Preinstallation Conference: Conduct conference at Project site to comply with requirements in Division 01 Section "Project Management and Coordination." Review methods and procedures related to carpet tile installation including, but not limited to, the following:
 - 1. Review delivery, storage, and handling procedures.
 - 2. Review ambient conditions and ventilation procedures.

1.5 DELIVERY, STORAGE, AND HANDLING

- A. Comply with CRI 104, Section 5, "Storage and Handling."

1.6 PROJECT CONDITIONS

- A. Comply with CRI 104, Section 7.2, "Site Conditions; Temperature and Humidity" and Section 7.12, "Ventilation."
- B. Environmental Limitations: Do not install carpet tiles until wet work in spaces is complete and dry, and ambient temperature and humidity conditions are maintained at the levels indicated for Project when occupied for its intended use.

- C. Do not install carpet tiles over concrete slabs until slabs have cured and are sufficiently dry to bond with adhesive and concrete slabs have pH range recommended by carpet tile manufacturer.

1.7 WARRANTY

- A. Special Warranty for Carpet Tiles: Manufacturer's standard form in which manufacturer agrees to repair or replace components of carpet tile installation that fail in materials or workmanship within specified warranty period.
 - 1. Warranty does not include deterioration or failure of carpet tile due to unusual traffic, failure of substrate, vandalism, or abuse.
 - 2. Failures include, but are not limited to, more than 10 percent loss of face fiber, edge raveling, snags, runs, loss of tuft bind strength, dimensional stability, excess static discharge, and delamination.
 - 3. Warranty Period: 10 years from date of Final Acceptance.

1.8 EXTRA MATERIALS

- A. Furnish extra materials described below, before installation begins, that match products installed and that are packaged with protective covering for storage and identified with labels describing contents.
 - 1. Carpet Tile: Full-size units equal to 5 percent of amount installed for each type indicated, but not less than 10 sq. yd.

PART 2 - PRODUCTS

2.1 CARPET TILE (CARPET TILE 1)

- A. Basis of Design: 'AMBASSADOR-TF-CHARCOAL WITH TF TAPE' by Matworks. Color as selected by Architect from manufacturer's full range. Subject to compliance with requirements, comparable products may be provided by one of the following:
 - 1. Milliken
 - 2. Mohawk Group.
 - 3. Shaw Contract Commercial Carpet, www.shawcontract.com.
 - 4. Interface Commercial Carpet.
- B. Size: 19.69" x 19.69"
- C. Overall thickness: 043"
- D. Material: Blend of polypropylene & polyethylene terephthalate (PET)
- E. Material weight: 50 ounces/yard²
- F. Backing: Bitumen

- G. Installation: Glue down

2.2 CARPET TILE (CARPET TILE 2)

- A. Basis of Design: Remix Remastered-Backbeatbeat, 20oz with Comfort Plus Cushion, antimicrobial protection, 39.4x39.4 size as manufactured by Milliken. Color as selected by Architect from manufacturer's full range. Subject to compliance with requirements, comparable products may be provided by one of the following:
 - 1. Milliken
 - 2. Mohawk Group.
 - 3. Shaw Contract Commercial Carpet, www.shawcontract.com.
 - 4. Interface Commercial Carpet.

2.3 CARPET TILE (CARPET TILE 3)

- A. Basis of Design: Remix Remastered-Freestyle, 20oz with Comfort Plus Cushion, antimicrobial protection, 39.4x39.4 size as manufactured by Milliken. Color as selected by Architect from manufacturer's full range. Subject to compliance with requirements, comparable products may be provided by one of the following:
 - 1. Milliken
 - 2. Mohawk Group.
 - 3. Shaw Contract Commercial Carpet, www.shawcontract.com.
 - 4. Interface Commercial Carpet.

2.4 INSTALLATION ACCESSORIES

- A. Trowelable Leveling and Patching Compounds: Latex-modified, hydraulic-cement-based formulation provided or recommended by carpet tile manufacturer.
- B. Adhesives: Water-resistant, mildew-resistant, nonstaining, pressure-sensitive type to suit products and subfloor conditions indicated, that complies with flammability requirements for installed carpet tile and is recommended by carpet tile manufacturer for releasable installation.
 - 1. VOC Limits: Provide adhesives that comply with the following limits for VOC content when tested according to ASTM D 5116:
 - a. Total VOCs: 10.00 mg/sq. m x h.
 - b. Formaldehyde: 0.05 mg/sq. m x h.
 - c. 2-Ethyl-1-Hexanol: 3.00 mg/sq. m x h.
- C. Metallic Edge Trim: Locations as indicated.
 - 1. Trep-E by Schluter Systems.
 - 2. Schiene radius / AE by Schluter Systems.

3. Finish: As selected by Architect from manufacturer's full range.

PART 3 - EXECUTION

3.1 EXAMINATION

- A. Examine substrates, areas, and conditions, with Installer present, for compliance with requirements for maximum moisture content, alkalinity range, installation tolerances, and other conditions affecting carpet tile performance. Examine carpet tile for type, color, pattern, and potential defects.
- B. Concrete Subfloors: Verify that concrete slabs comply with ASTM F 710 and the following:
 1. Slab substrates are dry and free of curing compounds, sealers, hardeners, and other materials that may interfere with adhesive bond. Determine adhesion and dryness characteristics by performing bond and moisture tests recommended by carpet tile manufacturer.
 2. Subfloor finishes comply with requirements specified in Division 03 Section "Cast-in-Place Concrete" for slabs receiving carpet tile.
 3. Subfloors are free of cracks, ridges, depressions, scale, and foreign deposits.
- C. Proceed with installation only after unsatisfactory conditions have been corrected.

3.2 PREPARATION

- A. General: Comply with CRI 104, Section 6.2, "Site Conditions; Floor Preparation," and with carpet tile manufacturer's written installation instructions for preparing substrates indicated to receive carpet tile installation.
- B. Use trowelable leveling and patching compounds, according to manufacturer's written instructions, to fill cracks, holes, depressions, and protrusions in substrates. Fill or level cracks, holes, and depressions 1/8 inch wide or wider and protrusions more than 1/32 inch, unless more stringent requirements are required by manufacturer's written instructions.
- C. Remove coatings, including curing compounds, and other substances that are incompatible with adhesives and that contain soap, wax, oil, or silicone, without using solvents. Use mechanical methods recommended in writing by carpet tile manufacturer.
- D. Clean metal substrates of grease, oil, soil and rust, and prime if directed by adhesive manufacturer. Rough sand painted metal surfaces and remove loose paint. Sand aluminum surfaces, to remove metal oxides, immediately before applying adhesive.
- E. Broom and vacuum clean substrates to be covered immediately before installing carpet tile.

3.3 INSTALLATION

- A. General: Comply with CRI 104, Section 14, "Carpet Modules," and with carpet tile manufacturer's written installation instructions.

- B. Installation Method: As recommended in writing by carpet tile manufacturer.
- C. Maintain dye lot integrity. Do not mix dye lots in same area.
- D. Install pattern parallel to walls and borders.

3.4 CLEANING AND PROTECTION

- A. Perform the following operations immediately after installing carpet tile:
 1. Remove excess adhesive, seam sealer, and other surface blemishes using cleaner recommended by carpet tile manufacturer.
 2. Remove yarns that protrude from carpet tile surface.
 3. Vacuum carpet tile using commercial machine with face-beater element.
- B. Protect installed carpet tile to comply with CRI 104, Section 16, "Protection of Indoor Installations."
- C. Protect carpet tile against damage from construction operations and placement of equipment and fixtures during the remainder of construction period. Use protection methods indicated or recommended in writing by carpet tile manufacturer.

END OF SECTION 096813

SECTION 096810 - SHEET CARPETING

PART 1 - GENERAL

1.1 SUMMARY

- A. This Section includes tufted and woven carpet as indicated on the drawings.

1.2 SUBMITTALS

- A. Product Data: For each product indicated.
- B. Shop Drawings: Show the following:
 - 1. Carpet type, color, and dye lot.
 - 2. Seam locations.
 - 3. Pattern type, repeat size, location, direction, and starting point.
 - 4. Pile direction.
 - 5. Insets and borders.
 - 6. Edge, transition, and other accessory strips.
 - 7. Transition details to other flooring materials.
 - 8. Carpet cushion.
- C. Samples: For each color and texture required.
 - 1. Carpet: 12-inch- square Sample.
 - 2. Exposed Edge, Transition, and other Accessory Stripping: 12-inch- long Samples.
 - 3. Carpet Cushion: 6-inch- square Sample.
- D. Product Schedule: For carpet, use same designations indicated on Drawings.
- E. Maintenance data.

1.3 QUALITY ASSURANCE

- A. Installer Qualifications: An experienced installer who is certified by the Floor Covering Installation Board or who can demonstrate compliance with its certification program requirements.
- B. Mockups: Before installing carpet, build mockups to verify selections made under sample submittals and to demonstrate aesthetic effects and set quality standards for material and execution.

1.4 DELIVERY, STORAGE, AND HANDLING

- A. Comply with CRI 104, Section 5, "Storage and Handling."

1.5 PROJECT CONDITIONS

- A. Comply with CRI 104, Section 7.2, "Site Conditions; Temperature and Humidity" and Section 7.12, "Ventilation."
- B. Environmental Limitations: Do not install carpet until wet work in spaces is complete and dry, and ambient temperature and humidity conditions are maintained at the levels indicated for Project when occupied for its intended use.
- C. Do not install carpet over concrete slabs until slabs have cured and are sufficiently dry to bond with adhesive and concrete slabs have pH range recommended by manufacturer.
- D. Where demountable partitions or other items are indicated for installation on top of carpet, install carpet tile before installing these items.

1.6 WARRANTY

- A. Special Warranty for Carpet: Manufacturer's standard form in which manufacturer agrees to repair or replace components of carpet installation that fail in materials or workmanship within specified warranty period. Failures include, but are not limited to, more than 10 percent loss of face fiber, edge raveling, snags, runs, loss of tuft bind strength, excess static discharge, and delamination.
 - 1. Warranty Period: 10 years from date of Final Acceptance.
- B. Special Warranty for Carpet Cushion: Manufacturer agrees to repair or replace components of carpet cushion installation that fail in materials or workmanship within specified warranty period.
 - 1. Warranty includes consequent removal and replacement of carpet and accessories.
 - 2. Warranty does not include deterioration or failure of carpet cushion due to unusual traffic, failure of substrate, vandalism, or abuse.
 - 3. Failure includes, but is not limited to, permanent indentation or compression.
 - 4. Warranty Period: 10 years from date of Final Acceptance.

1.7 EXTRA MATERIALS

- A. Furnish extra materials described below, before installation begins, that match products installed and that are packaged with protective covering for storage and identified with labels describing contents.
 - 1. Carpet: Carpet tiles equal to 5 percent of amount installed for each type indicated, but not less than 10 sq. yd.

PART 2 - PRODUCTS

2.1 BROADLOOM SHEET CARPET

- A. Basis of Design Product: Subject to compliance with requirements provide broadloom carpet Notion Ultraloc MB by Shaw Contract Commercial Carpet or equal product by one of the following:
 - 1. Mohawk Group.
 - 2. Interface Commercial Carpet.
 - 3. Milliken
 - 4. Durkan Hospitality
 - 5. Manning Commercial

- B. Fiber Content: 100 percent nylon 6/6
- C. Fiber Type: ECO Solution Q Nylon, type 6/6
- D. Pile Characteristic: Multi-Level Pattern Cut/Loop.
- E. Yarn Twist: 5.4
- F. Density: 126 tufts / square inch (6595 oz/yd³)
- G. Pile Thickness: nominal .34" sheared for finished carpet per ASTM D6859.
- H. Stitches: 10.0 per inch.
- I. Gage: 1/12 inch.
- J. Tufted Weight: 24 oz / yd²
- K. Total Thickness: 0.274 inches.
- L. Primary Backing: Synthetic
- M. Secondary Backing: Ultralock MB.
- N. Backcoating: Consult manufacturer.
- O. Width: 12 feet or 13.5 feet.
- P. Applied Soil-Resistance Treatment: Manufacturer's standard material.
- Q. Antimicrobial Treatment: Manufacturer's standard material.
- R. At Stair Locations: Provide binding at carpet edges for stair runner applications (hemmed edge).**

S. Custom strip at thread nosing: Provide 2” accent color band at stair nosing to comply with ICC A1171.1-2009-504.5.1

T. Performance Characteristics: As follows:

1. Critical Radiant Flux Classification: Not less than 0.45 W/sq. cm.
2. Delamination: Not less than 3.2 per ASTM D 3936.
3. Resistance to Insects: Comply with AATCC 24.
4. Colorfastness to Crocking: Not less than 4, wet and dry, per AATCC 165.
5. Colorfastness to Light: Not less than 4 after 40 AFU (AATCC fading units) per AATCC 16, Option E.
6. Antimicrobial Activity: Not less than 2-mm halo of inhibition for gram-positive bacteria; not less than 1-mm halo of inhibition for gram-negative bacteria; no fungal growth; per AATCC 174.
7. Electrostatic Propensity: Less than 3.5 kV per AATCC 134.
8. Environmental Requirements: Provide carpet that complies with testing and product requirements of Carpet and Rug Institute's "Green Label Plus" program.

2.2 INSTALLATION ACCESSORIES

- A. Trowelable Leveling and Patching Compounds: Latex-modified, hydraulic-cement-based formulation provided or recommended by carpet manufacturer.
- B. Adhesives: Water-resistant, mildew-resistant, nonstaining type to suit products and subfloor conditions indicated, that complies with flammability requirements for installed carpet and is recommended or provided by carpet manufacturer.
 1. VOC Limits: Provide adhesives with VOC content not more than 50g/L when calculated according to 40 CFR 59, Subpart D (EPA method 24).
- C. Tackless Carpet Stripping: Water-resistant plywood, in strips as required to match cushion thickness and that comply with CRI 104, Section 12.2.
- D. Seam Adhesive: Hot-melt adhesive tape or similar product recommended by carpet manufacturer for sealing and taping seams and butting cut edges at backing to form secure seams and to prevent pile loss at seams.

PART 3 - EXECUTION

3.1 INSTALLATION

- A. Comply with CRI 104 and carpet manufacturer's written installation instructions for the following:
 1. Direct-Glue-Down Installation: Comply with CRI 104, Section 9, "Direct Glue-Down Installation."

- B. Comply with CR1 104, Section 13 'Carpet on Stairs'.**
- C. Comply with carpet manufacturer's written recommendations and Shop Drawings for seam locations and direction of carpet; maintain uniformity of carpet direction and lay of pile. At doorways, center seams under the door in closed position.
- D. Extend carpet into toe spaces, door reveals, closets, open-bottomed obstructions, removable flanges, alcoves, and similar openings.
- E. Install pattern parallel to walls and borders.

END OF SECTION 096816

SECTION 099100 - PAINTING

PART 1 - GENERAL

1.1 SUMMARY

- A. This Section includes surface preparation and field painting of exposed exterior and interior items and surfaces.

1.2 SUBMITTALS

- A. Product Data:
 - 1. For each product indicated.
 - 2. For paints and coatings, including printed statement of VOC content.
- B. Samples: For each type of finish-coat material indicated.

1.3 QUALITY ASSURANCE

- A. Benchmark Samples (Mockups): Provide a full-coat benchmark finish sample for each type of coating and substrate required. Comply with procedures specified in PDCA P5.
 - 1. Wall Surfaces: Provide samples on at least 100 sq. ft.
 - 2. Small Areas and Items: Architect will designate items or areas required.
 - 3. Final approval of colors will be from benchmark samples.

1.4 PROJECT CONDITIONS

- A. Store materials not in use in tightly covered containers in a well-ventilated area at a minimum ambient temperature of 45 deg F. Maintain storage containers in a clean condition, free of foreign materials and residue.
- B. Apply waterborne paints only when temperatures of surfaces to be painted and surrounding air are between 50 and 90 deg F.
- C. Apply solvent-thinned paints only when temperatures of surfaces to be painted and surrounding air are between 45 and 95 deg F.
- D. Do not apply paint in snow, rain, fog, or mist; or when relative humidity exceeds 85 percent; or at temperatures less than 5 deg F above the dew point; or to damp or wet surfaces.

1.5 EXTRA MATERIALS

- A. Furnish extra paint materials from the same production run as the materials applied and in the quantities described below. Package with protective covering for storage and identify with labels describing contents. Deliver extra materials to Owner.
 - 1. Quantity: 3 percent, but not less than 1 gal. or 1 case, as appropriate, of each material and color applied.

PART 2 - PRODUCTS

2.1 MANUFACTURERS

- A. Products: Subject to compliance with requirements, provide one of the products listed in other Part 2 articles.
- B. Manufacturers' Names: Shortened versions (shown in parentheses) of the following manufacturers' names are used in other Part 2 articles:
 - 1. Benjamin Moore & Co. (Benjamin Moore).
 - 2. PPG Paints.
 - 3. Sherwin-Williams Co. (Sherwin-Williams).
 - 4. Valspar

2.2 PAINT MATERIALS, GENERAL

- A. Material Compatibility: Provide block fillers, primers, and finish-coat materials that are compatible with one another and with the substrates indicated under conditions of service and application, as demonstrated by manufacturer based on testing and field experience.
- B. Material Quality: Provide manufacturer's best-quality paint material of the various coating types specified that are factory formulated and recommended by manufacturer for application indicated. Paint-material containers not displaying manufacturer's product identification will not be acceptable.
- C. VOC Content: Products shall comply with VOC limits of authorities having jurisdiction and, for interior paints and coatings applied at Project site, the following VOC limits, exclusive of colorants added to a tint base, when calculated according to 40 CFR 59, Subpart D (EPA Method 24).
 - 1. Flat Paints and Coatings: 50 g/L.
 - 2. Nonflat Paints and Coatings: 150 g/L.
 - 3. Dry-Fog Coatings: 400 g/L.
 - 4. Primers, Sealers, and Undercoaters: 200 g/L.
 - 5. Anticorrosive and Antirust Paints Applied to Ferrous Metals: 250 g/L.
 - 6. Zinc-Rich Industrial Maintenance Primers: 340 g/L.
 - 7. Pretreatment Wash Primers: 420 g/L.
 - 8. Floor Coatings: 100 g/L.
 - 9. Shellacs, Clear: 730 g/L.

10. Shellacs, Pigmented: 550 g/L.

- D. Low-Emitting Materials: Interior paints and coatings shall comply with the testing and product requirements of the California Department of Public Health's "Standard Method for the Testing and Evaluation of Volatile Organic Chemical Emissions from Indoor Sources Using Environmental Chambers."
- E. Colors: As selected from manufacturer's full range.

2.3 PREPARATORY COATS

- A. Concrete Unit Masonry Block Filler: High-performance latex block filler of finish coat manufacturer and recommended in writing by manufacturer for use with finish coat and on substrate indicated.
- B. Exterior Primer for Metal: Exterior alkyd or latex-based primer of finish coat manufacturer and recommended in writing by manufacturer for use with finish coat and on substrate indicated.
 - 1. Ferrous-Metal and Aluminum Substrates: Rust-inhibitive metal primer.
 - 2. Zinc-Coated Metal Substrates: Galvanized metal primer.
 - 3. Where manufacturer does not recommend a separate primer formulation on substrate indicated, use paint specified for finish coat.
- C. Interior Primer: Interior latex-based or alkyd primer of finish coat manufacturer and recommended in writing by manufacturer for use with finish coat and on substrate indicated.
 - 1. Ferrous-Metal Substrates: Quick drying, rust-inhibitive metal primer.
 - 2. Zinc-Coated Metal Substrates: Galvanized metal primer.
 - 3. Where manufacturer does not recommend a separate primer formulation on substrate indicated, use paint specified for finish coat.

2.4 EXTERIOR FINISH COATS

- A. Exterior Semi-Gloss Acrylic Enamel: (Metal)
 - 1. Benjamin Moore; Corotech DTM Semi-Gloss, 182
 - 2. PPG Paints; Pitt-Tech Plus Int/Ext DTM Semi-Gloss, 90-1210
 - 3. Sherwin-Williams; Pro Industrial DTM Waterborne Acrylic Semi-Gloss, B66-1150 Series
- B. Exterior Satin Acrylic Enamel: (Masonry)
 - 1. Benjamin Moore; ben Exterior Paint Low Lustre, 542
 - 2. PPG Paints; Speedhide Exterior Latex Satin, 53114
 - 3. Sherwin-Williams A-100 Exterior Latex Satin, A82 Series.

2.5 INTERIOR FINISH COATS

- A. Interior Flat Acrylic Enamel: (Concrete, Masonry, Plaster, Gypsum board)

1. Benjamin Moore; Natura Interior Paint Flat, 512
 2. PPG Paints; Pure Performance Interior Latex Flat, 9-110XI
 3. Sherwin-Williams; ProMar 200 Zero-VOC Interior Latex Flat, B30-2600
- B. Interior Semigloss Acrylic Enamel: (metal)
1. Benjamin Moore; Corotech DTM Semi-Gloss, 182
 2. PPG Paints; Pitt-Tech Plus Int/Ext DTM Semi-Gloss, 90-1210
 3. Sherwin-Williams; Pro Industrial DTM Waterborne Acrylic Semi-Gloss, B66-1150 Series
- C. Interior Flat Dryfall (other than structural steel and roof deck)
1. Benjamin Moore; Super Kote 5000 Latex Dryfall Flat, 110-1
 2. PPG Paints; Speedhide Interior Dry-Fog Spray Paint Latex Flat, 6-715XI
 3. Sherwin Williams; Pro Industrial Waterborne Acrylic Dryfall Flat, B42 Series
- D. Interior Waterbased Epoxy: For Toilets, Restrooms, Locker Rooms, Showers.
1. Benjamin Moore; Waterborne Polyamide Epoxy Gloss Coating, M42
 2. PPG Paints; Aquapon WB Waterbased Epoxy Gloss, 98-1
 3. Sherwin Williams; Pro Industrial Waterbased Catalyzed Epoxy Gloss, B73-300 Series

PART 3 - EXECUTION

3.1 APPLICATION

- A. Comply with procedures specified in PDCA P4 for inspection and acceptance of surfaces to be painted.
- B. Coordination of Work: Review other Sections in which primers are provided to ensure compatibility of the total system for various substrates. On request, furnish information on characteristics of finish materials to ensure use of compatible primers.
- C. Remove hardware and hardware accessories, plates, machined surfaces, lighting fixtures, and similar items already installed that are not to be painted. If removal is impractical or impossible because of size or weight of the item, provide surface-applied protection before surface preparation and painting.
1. After completing painting operations in each space or area, reinstall items removed using workers skilled in the trades involved.
- D. Surface Preparation: Clean and prepare surfaces to be painted according to manufacturer's written instructions for each particular substrate condition and as specified.
1. Provide barrier coats over incompatible primers or remove and reprime.
 2. Cementitious Materials: Remove efflorescence, chalk, dust, dirt, grease, oils, and release agents. Roughen as required to remove glaze. If hardeners or sealers have been used to improve curing, use mechanical methods of surface preparation.

3. Ferrous Metals: Clean ungalvanized ferrous-metal surfaces that have not been shop coated; remove oil, grease, dirt, loose mill scale, and other foreign substances. Use solvent or mechanical cleaning methods that comply with SSPC's recommendations.
 - a. Treat bare and sandblasted or pickled clean metal with a metal treatment wash coat before priming.
 - b. Touch up bare areas and shop-applied prime coats that have been damaged. Wire-brush, clean with solvents recommended by paint manufacturer, and touch up with same primer as the shop coat.
4. Galvanized Surfaces: Clean galvanized surfaces with nonpetroleum-based solvents so surface is free of oil and surface contaminants. Remove pretreatment from galvanized sheet metal fabricated from coil stock by mechanical methods.
5. Wood: Clean surfaces of dirt, oil, and other foreign substances with scrapers, mineral spirits, and sandpaper, as required. Sand surfaces exposed to view smooth and dust off.
 - a. Scrape and clean small, dry, seasoned knots, and apply a thin coat of white shellac or other recommended knot sealer before applying primer. After priming, fill holes and imperfections in finish surfaces with putty or plastic wood filler. Sand smooth when dried.
 - b. Prime, stain, or seal wood to be painted immediately on delivery. Prime edges, ends, faces, undersides, and back sides of wood, including cabinets, counters, cases, and paneling. Revise first subparagraph and associated subparagraphs below to suit Project.

E. Material Preparation:

1. Maintain containers used in mixing and applying paint in a clean condition, free of foreign materials and residue.
2. Stir material before application to produce a mixture of uniform density. Stir as required during application. Do not stir surface film into material. If necessary, remove surface film and strain material before using.

F. Exposed Surfaces: Include areas visible when permanent or built-in fixtures, grilles, convactor covers, covers for finned-tube radiation, and similar components are in place. Extend coatings in these areas, as required, to maintain system integrity and provide desired protection.

1. Paint surfaces behind movable equipment and furniture the same as similar exposed surfaces. Before final installation of equipment, paint surfaces behind permanently fixed equipment or furniture with prime coat only.
2. Paint interior surfaces of ducts with a flat, nonspecular black paint where visible through registers or grilles.
3. Paint back sides of access panels and removable or hinged covers to match exposed surfaces.
4. Finish exterior doors on tops, bottoms, and side edges the same as exterior faces.
5. Finish interior of wall and base cabinets and similar field-finished casework to match exterior.

G. Sand lightly between each succeeding enamel or varnish coat.

- H. Scheduling Painting: Apply first coat to surfaces that have been cleaned, pretreated, or otherwise prepared for painting as soon as practicable after preparation and before subsequent surface deterioration.
 - 1. If undercoats, stains, or other conditions show through final coat of paint, apply additional coats until paint film is of uniform finish, color, and appearance.
- I. Application Procedures: Apply paints and coatings by brush, roller, spray, or other applicators according to manufacturer's written instructions.
- J. Minimum Coating Thickness: Apply paint materials no thinner than manufacturer's recommended spreading rate. Provide total dry film thickness of the entire system as recommended by manufacturer.
- K. Mechanical and Electrical Work: Painting of mechanical and electrical work is limited to items exposed in equipment rooms and occupied spaces.
- L. Block Fillers: Apply block fillers to concrete masonry block at a rate to ensure complete coverage with pores filled.
- M. Prime Coats: Before applying finish coats, apply a prime coat, as recommended by manufacturer, to material that is required to be painted or finished and that has not been prime coated by others. Recoat primed and sealed surfaces where evidence of suction spots or unsealed areas in first coat appears, to ensure a finish coat with no burn-through or other defects due to insufficient sealing.
- N. Pigmented (Opaque) Finishes: Completely cover surfaces as necessary to provide a smooth, opaque surface of uniform finish, color, appearance, and coverage. Cloudiness, spotting, holidays, laps, brush marks, runs, sags, ropiness, or other surface imperfections will not be acceptable.
- O. Transparent (Clear) Finishes: Use multiple coats to produce a glass-smooth surface film of even luster. Provide a finish free of laps, runs, cloudiness, color irregularity, brush marks, orange peel, nail holes, or other surface imperfections.
- P. Stipple Enamel Finish: Roll and redistribute paint to an even and fine texture. Leave no evidence of rolling, such as laps, irregularity in texture, skid marks, or other surface imperfections.

3.2 CLEANING AND PROTECTING

- A. At the end of each workday, remove empty cans, rags, rubbish, and other discarded paint materials from Project site.
- B. Protect work of other trades, whether being painted or not, against damage from painting. Correct damage by cleaning, repairing or replacing, and repainting, as approved by Architect.
- C. Provide "Wet Paint" signs to protect newly painted finishes. After completing painting operations, remove temporary protective wrappings provided by others to protect their work.
 - 1. After work of other trades is complete, touch up and restore damaged or defaced painted surfaces. Comply with procedures specified in PDCA P1.

3.3 EXTERIOR PAINT SCHEDULE

- A. Concrete, Stucco, and Masonry (Other Than Concrete Unit Masonry):
 - 1. Acrylic Finish: Two finish coats over a primer.
 - a. Primer: Exterior concrete and masonry primer.
 - b. Finish Coats: Exterior full-gloss acrylic enamel for concrete, masonry, and wood.
- B. Ferrous Metal:
 - 1. Acrylic Finish: Two finish coats over a rust-inhibitive primer.
 - a. Primer: Exterior ferrous-metal primer (not required on shop-primed items).
 - b. Finish Coats: Exterior semi-gloss acrylic paint.
- C. Zinc-Coated Metal:
 - 1. Acrylic Finish: Two finish coats over a galvanized metal primer.
 - a. Primer: Exterior galvanized metal primer.
 - b. Finish Coats: Exterior semi-gloss acrylic paint.

3.4 INTERIOR PAINT SCHEDULE

- A. Concrete Unit Masonry:
 - 1. Acrylic Finish: Two finish coats over a block filler.
 - a. Block Filler: Concrete unit masonry block filler. (Provide primer in lieu of block filler at existing masonry.)
 - b. Finish Coats:
 - 1) Interior satin acrylic enamel in offices, classrooms, corridors
 - 2) Interior semi-gloss at toilets, showers, locker rooms, kitchen areas.
- B. Gypsum Board:
 - 1. Acrylic Finish: Two finish coats over a primer.
 - a. Primer: Interior gypsum board primer.
 - b. Finish Coats:
 - 1) Interior satin acrylic enamel in offices, classrooms, corridors.
 - 2) Interior semi-gloss finish at Janitor, Mechanical and Electrical Rooms.
 - 3) Interior semi-gloss at toilets, showers, locker rooms, kitchen areas.
- C. Ferrous Metal:
 - 1. Acrylic Finish: Two finish coats over a primer.
 - a. Primer: Interior ferrous-metal primer.
 - b. Finish Coats: Interior semi-gloss acrylic enamel.
- D. Zinc-Coated Metal:

1. Acrylic Finish: Two finish coats over a primer.
 - a. Primer: Interior zinc-coated metal primer.
 - b. Finish Coats: Interior semi-gloss acrylic enamel.

- E. All-Service Jacket over Insulation:
 1. Acrylic Finish: Two finish coats. Add fungicidal agent to render fabric mildew proof.
 - a. Finish Coats: Interior flat latex-emulsion size.

- F. Ceilings and associated ductwork and conduit:
 1. Low luster acrylic enamel finish: One coat over a primer.

END OF SECTION 099100

SECTION 101400 - SIGNAGE

PART 1 - GENERAL

1.1 SUMMARY

- A. This Section includes the following:

1. Panel Signs.

1.2 DEFINITIONS

- A. ADA-ABA Accessibility Guidelines: U.S. Architectural & Transportation Barriers Compliance Board's "Americans with Disabilities Act (ADA) Accessibility Guidelines for Buildings and Facilities; Architectural Barriers Act (ABA) Accessibility Guidelines."

1.3 ACTION SUBMITTALS

- A. Product Data: For each type of product indicated.
- B. Shop Drawings: Show fabrication and installation details for signs.
1. Show sign mounting heights, locations of supplementary supports to be provided by others, and accessories.
 2. Provide message list, typestyles, graphic elements including tactile characters and Braille, and layout for each sign.
 - a. Prior to the installation, the contractor shall supply in duplicate the signage finish schedule and shop drawings showing the colors, words, number and other information to be included on the signage as it is to be installed.
- C. Samples: Submit sample of each type of sign in the specified color and size, and a sample of the message holder grip-strip showing its attachment to the appropriate sign type.

1.4 QUALITY ASSURANCE

- A. Regulatory Requirements: Comply with applicable provisions in 2010 ADA Standards and ICC/ANSI A117.1 - 2009.

PART 2 - PRODUCTS

2.1 PANEL SIGNS

- A. Manufacturers: Subject to compliance with requirements, provide products by one of the following:
1. ASI Sign Systems, Inc.
 2. Best Sign Systems Inc.
 3. Corum Signs, Inc.
 4. Signature Signs, Incorporated.
 5. 2/90 Sign Systems.
- B. Interior Panel Signs: Provide smooth sign panel surfaces constructed to remain flat under installed conditions within a tolerance of plus or minus 1/16 inch measured diagonally from corner to corner, complying with the following requirements:
1. Laminated, Photomechanical etched: Raised graphics with Braille 1/32 inch above surface with finished with a professional coat of acrylic polyurethane enamel in the specified color and laminated to a 1/8" opaque acrylic back.
 2. Edge Condition: Beveled.
 3. Corner Condition: Square with no border.
 4. Finished sign thickness: 1/4".
 5. Mounting: Unframed.
 - a. Wall mounted with two faced tape.
 - 1) Mounting tape must allow easy removal of sign without damage to wall material or finish.
 - b. Exterior Wall mounted: Use exterior rated adhesive recommended by manufacturer.
 6. Color: Specified color shall be available within the manufacturers full range.
 7. Tactile Characters: Characters and Grade 2 Braille raised 1/32 inch above surface with contrasting colors as specified.
- C. Graphic Content and Style:
1. Graphic content and layout shall be as shown on drawings.
 - a. Letter Style is to be: Helvetica Medium – Upper Case Letters
 - b. Room Numbers are to be 1" high
 - c. Text is to be 3/4" high
- D. Tactile and Braille Sign: Manufacturer's standard process for producing text and symbols complying with ADA-ABA Accessibility Guidelines and with ICC/ANSI A117.1 - 2009. Text shall be accompanied by Grade 2 Braille. Produce precisely formed characters with square-cut edges free from burrs and cut marks; Braille dots with domed or rounded shape.

1. Raised-Copy Thickness: Not less than 1/32 inch.

PART 3 - EXECUTION

3.1 INSTALLATION

- A. Locate signs and accessories where indicated, using mounting methods of types described and complying with manufacturer's written instructions.
 1. Install signs level, plumb, and at heights indicated, with sign surfaces free of distortion and other defects in appearance.
 2. Interior Wall Signs: Install signs on walls adjacent to latch side of door where applicable. Where not indicated or possible, such as double doors, install signs on nearest adjacent walls. Locate to allow approach within 3 inches of sign without encountering protruding objects or standing within swing of door.
- B. Wall-Mounted Signs: Comply with sign manufacturer's written instructions except where more stringent requirements apply.
 1. Two-Face Tape: Mount signs to smooth, nonporous surfaces. Do not use this method for vinyl-covered rough surfaces or exterior conditions.
 - a. Installation accessories shall be furnished by the signage manufacturer. Do not use installation materials from any other source.
 - 1) Mounting tape must allow easy removal of sign without damage to wall material or finish.
 2. Exterior Conditions: Use adhesive approved by manufacturer for exterior conditions.
 2. Signs Mounted on Glass: Provide matching opaque plate on opposite side of glass to conceal mounting materials.
 - a. The color of the blank plate is to match the sign color. The size of the blank plate is to match the size of the sign.

Signage Schedule:

Reference Room No.	Permanent Text	Type	Qty
100 VESTIBULE	—	—	—
101 EXISTING STAIR	—	—	—
102 EQUIPMENT ROOM	102 EQUIPMENT ROOM	B	1
103 OFFICE	103	A	1
104 OFFICE	104	A	1
105 STORAGE ROOM	105	A	1
106 OFFICE	106	A	1
107 OFFICE	107	A	1
108 MECHANICAL ROOM	MECHANICAL ROOM	B*	1
109 ELECTRICAL ROOM	—	—	—
110 VENDING	110	A	1
111 WAITING	—	—	—
112 RECEPTION	—	—	—
113 VESTIBULE	—	—	—
114 VETERANS CENTER	—	—	—
114A BREAK	—	—	—
115 CORRIDOR	—	—	—
116 STAFF # 1	116	A	1
117 STAFF # 2	117	A	1
118 DIRECTOR OFFICE	118	A	1
119 STUDY # 1	119	A	1
120 QUIET ROOM	120	A	1
121 ELECTRICAL ROOM	121 ELECTRICAL ROOM	B	1
122 IT ROOM	122	A	1
123 JANITORS CLOSET	123	A	1
124 MENS TOILET ROOM	124 MEN	C	1
125 VESTIBULE	—	—	—
126 EXISTING STAIR	—	—	—
127 ELEVATOR EQUIPMENT ROOM	127 ELEVATOR EQUIPMENT ROOM	B	1
128 EXISTING ELEVATOR	—	—	—
129 STUDY # 2	129	A	1
130 STUDY # 3	130	A	1
131 RISER ROOM	—	—	—
132 COMMON AREA	—	—	—
133 EXISTING OPEN STAIR	—	—	—
134 VESTIBULE	—	—	—
135 COMMON AREA	—	—	—
136 STUDY # 4	136	A	1
137 STUDY # 5	137	A	1
138 STUDY # 6	138	A	1
139 WOMENS TOILET ROOM	139 WOMEN	D	1
140 COVERED CANOPY	—	—	—

* Denotes Exterior Sign

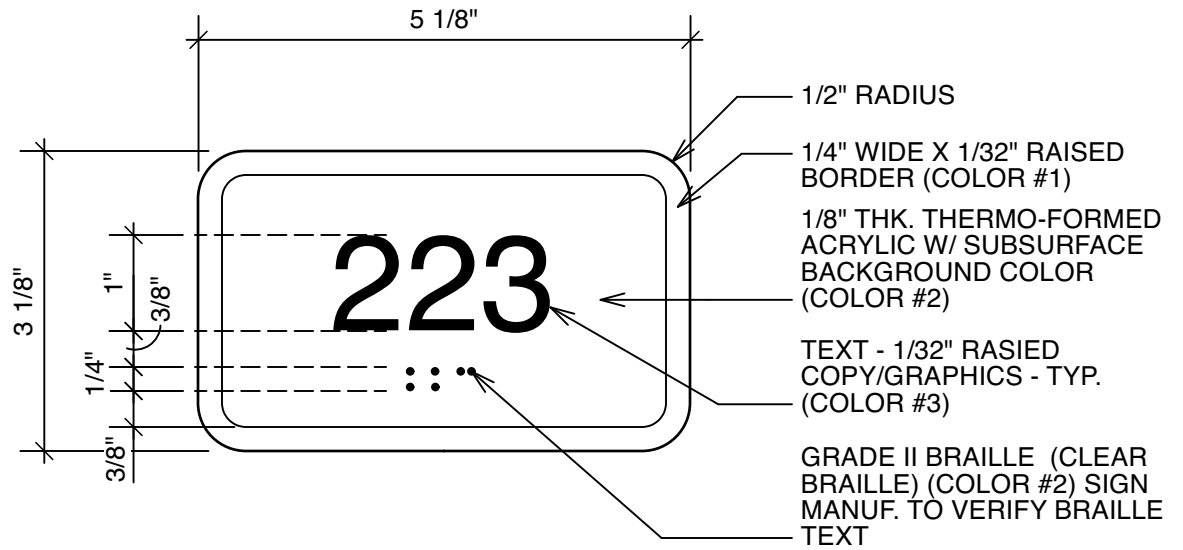

GENERAL SIGNAGE
(TYPE A)

1/4" WIDE X 1/32" RAISED BORDER (COLOR #1)

1/8" THK. THERMO-FORMED ACRYLIC W/ SUBSURFACE BACKGROUND COLOR (COLOR #2)

TEXT - 1/32" RAISED COPY/GRAPHICS - TYP. (COLOR #3)

GRADE II BRAILLE (CLEAR BRAILLE) (COLOR #2) SIGN MANUF. TO VERIFY BRAILLE TEXT

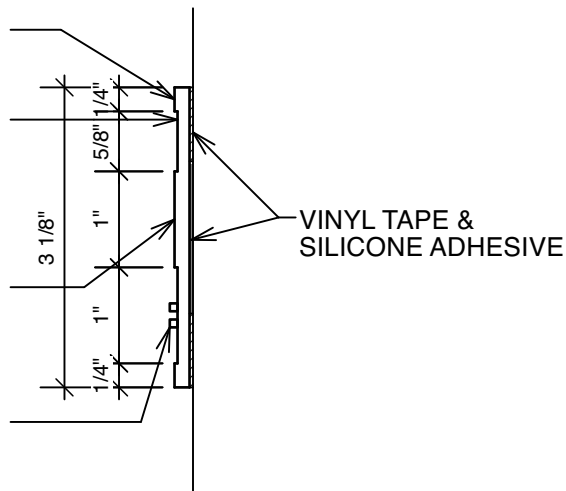

GENERAL SIGNAGE SECTION
(TYPE A)

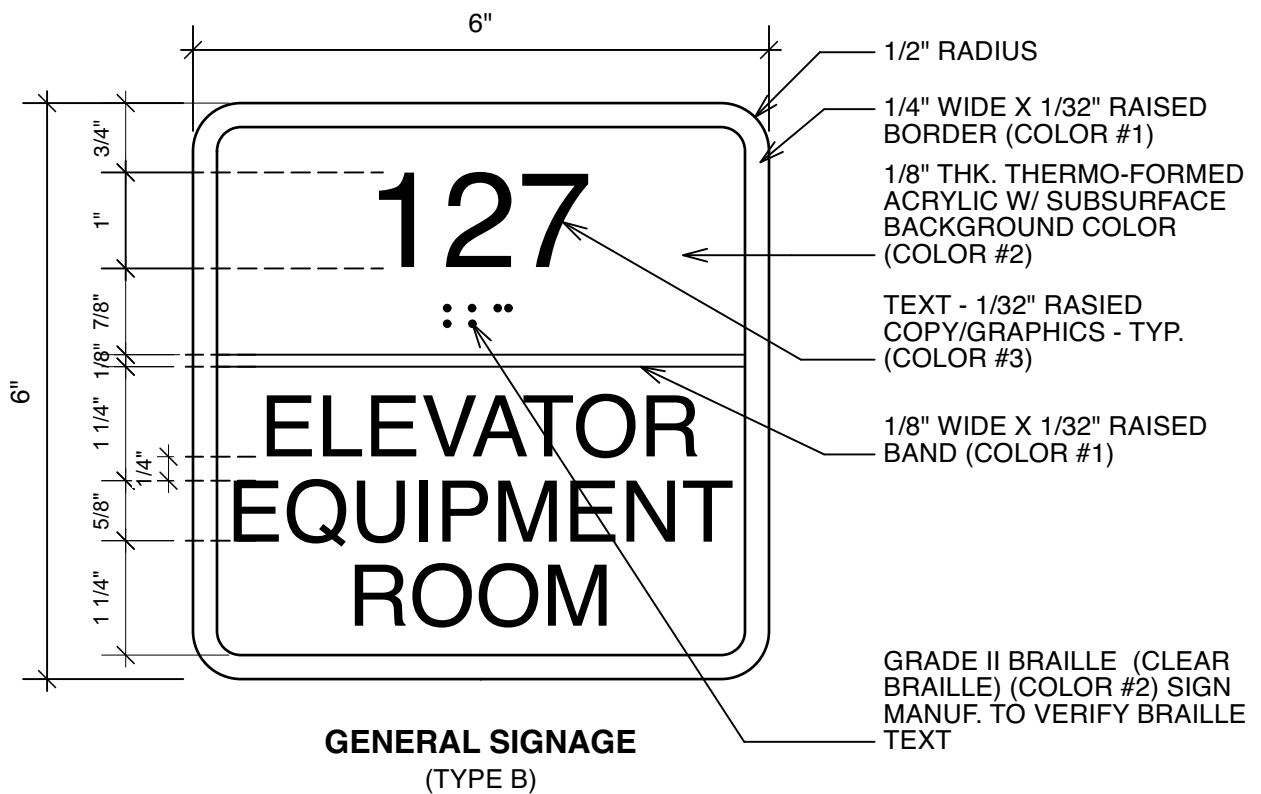
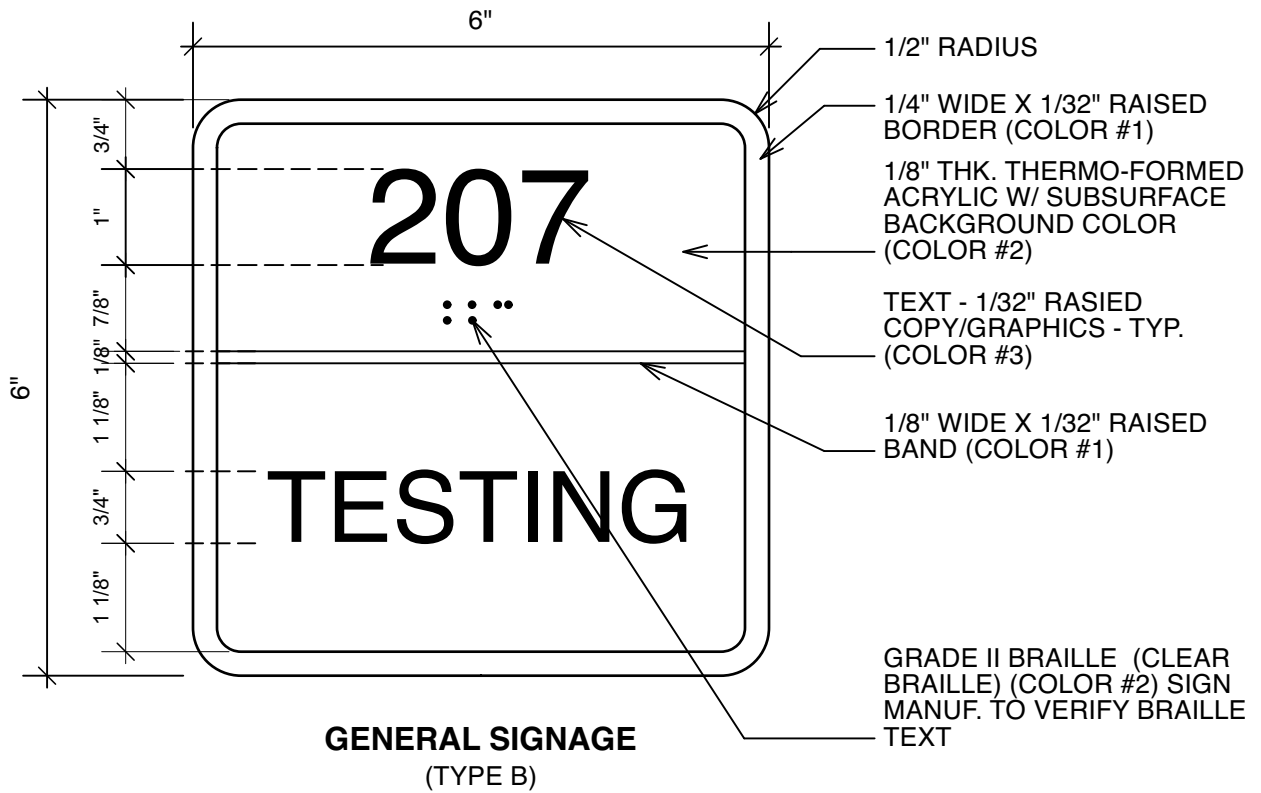

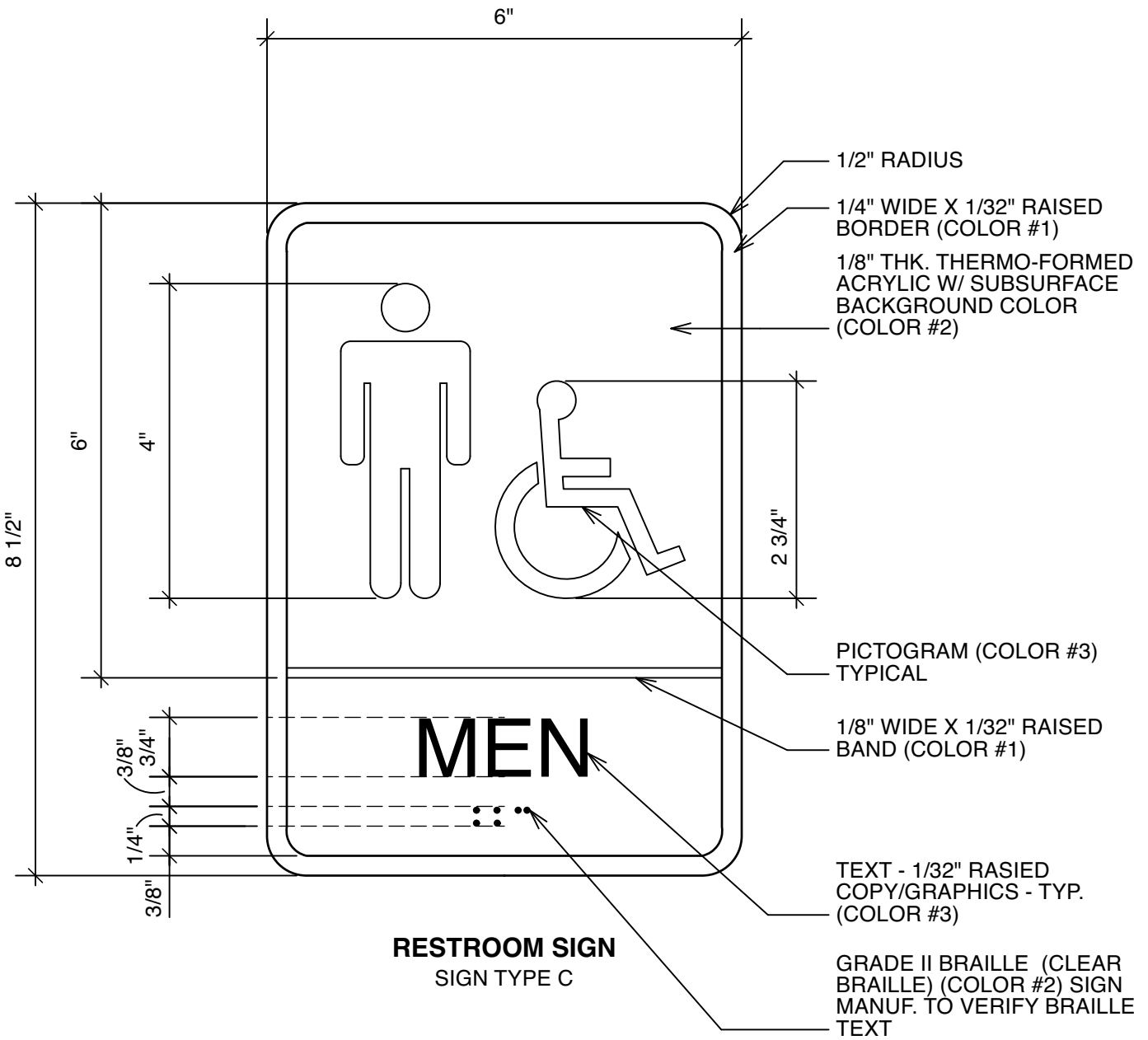

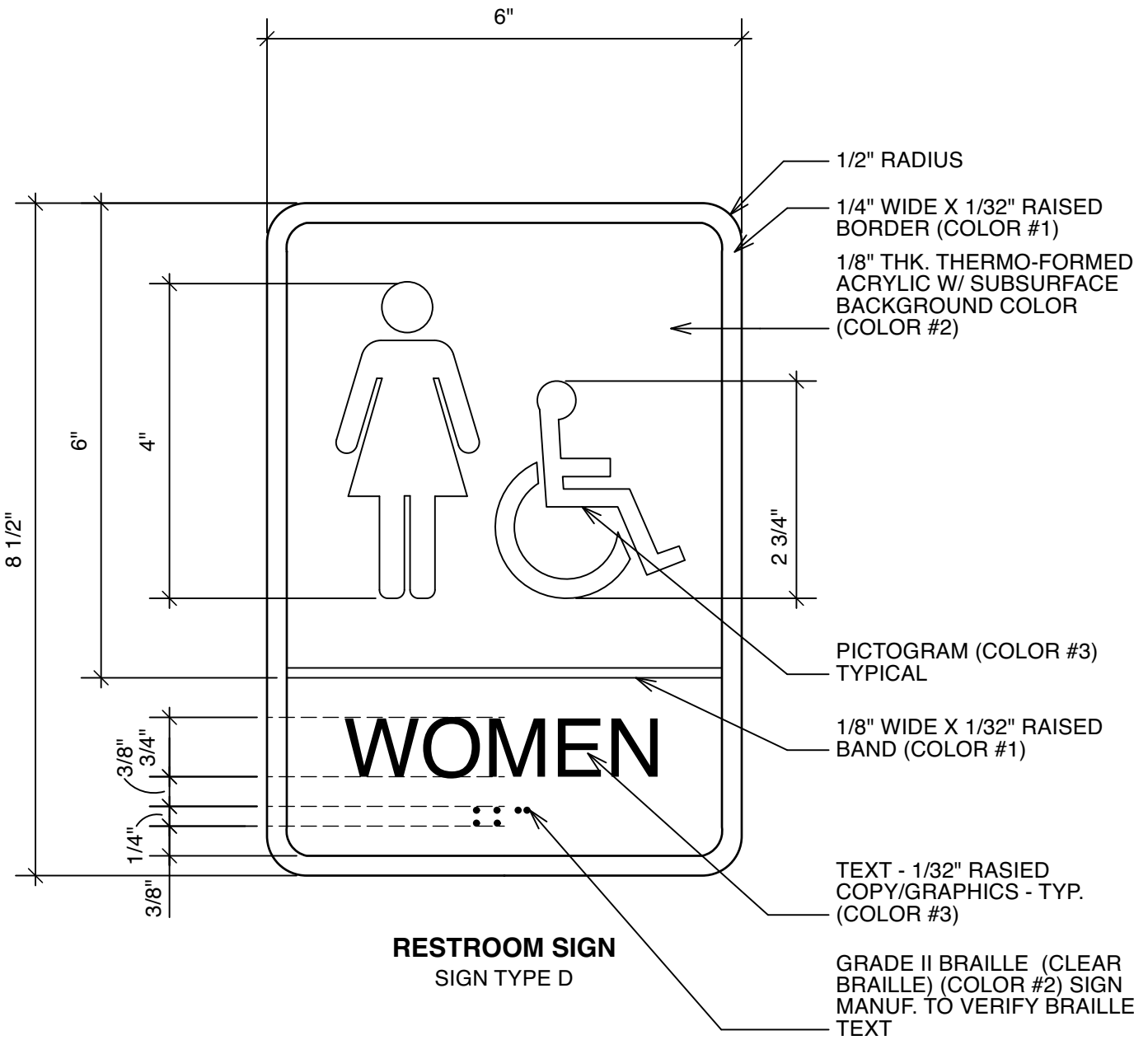

C. Signage Schedule Notes:

1. Allow for a minimum of 10 signs installed on glass.
2. All signage on the project that falls under the jurisdiction of the American with Disabilities Act is to be provided as required to comply with all applicable requirements of ADA. It is the responsibility of the contractor and the signage manufacturer to ensure that all signage complies with ADA.
3. Text in Type 1 Sign slides to be determined by owner during construction.

PART 4 - GUARANTEE

4.1 Any signs that do not remain securely bonded to the substrate for a period of 1 year after acceptance of the project shall be removed and properly reinstalled by the contractor at no additional cost to the owner.

A. Signage Drawings: Attached.

END OF SECTION 101400

SECTION 102113 - TOILET COMPARTMENTS

PART 1 - GENERAL

1.1 SUMMARY

- A. Section includes solid-plastic toilet compartments configured as follows:
 - 1. Toilet Enclosures: Floor mounted, overhead braced.
 - 2. Urinal Screens: Wall hung and floor braced.
- B. Related Sections:
 - 1. Division 10 Section "Toilet, Bath, and Laundry Accessories" for partition mounted devices.

1.2 ACTION SUBMITTALS

- A. Product Data: For each type of product.
- B. Shop Drawings: Include plans, elevations, sections, details, and attachment details.
- C. Samples: For each exposed finish.

PART 2 - PRODUCTS

2.1 SOLID-PLASTIC TOILET COMPARTMENTS

- A. Manufacturers: Subject to compliance with requirements, provide products by one of the following:
 - 1. ASI Global Partitions.
 - 2. Accurate Partitions Corporation.
 - 3. All American Metal Corp.
 - 4. American Sanitary Partition Corporation.
 - 5. Bradley Corporation; Mills Partitions.
 - 6. General Partitions Mfg. Corp.
 - 7. Global Steel Products Corp.
 - 8. Scranton Products – Hindy Hider.
- B. Toilet-Enclosure Style: Overhead braced, floor anchored.
- C. Urinal-Screen Style: Wall hung, floor anchored.

- D. Door, Panel, and Pilaster Construction: Solid, high-density polyethylene (HDPE) panel material, not less than 1 inch thick, seamless, with eased edges, no-sightline system, and with homogenous color and pattern throughout thickness of material.
 - 1. Heat-Sink Strip: Manufacturer's standard continuous, extruded-aluminum or stainless-steel strip fastened to exposed bottom edges of solid-plastic components to hinder malicious combustion.
 - 2. Color and Pattern: As selected by Architect from manufacturer's full range for both color and pattern. Patterns to include Orange Peel Texture, Ex (stipple) texture, and Hammered texture.
- E. Pilaster Shoes and Sleeves: Stainless steel. ASTM A 666, Type 304, not less than 0.0312 inch specified thickness and three inches high, finished to match hardware.
- F. Urinal-Screen Post: Manufacturer's standard post design of 1-3/4-inch- square, aluminum tube with satin finish; with shoe.
- G. Brackets (Fittings):
 - 1. Full-Height (Continuous) Type: Manufacturer's standard design; stainless steel.

2.2 HARDWARE AND ACCESSORIES

- A. Hardware and Accessories: Manufacturer's heavy-duty stainless-steel operating hardware and accessories.
 - 1. Provide units that comply with regulatory requirements for accessibility at compartments designated as accessible.
- B. Overhead Bracing: Manufacturer's standard continuous, extruded-aluminum head rail with antigrip profile and in manufacturer's standard finish.
- C. Anchorages and Fasteners: Stainless steel, finished to match hardware, with theft-resistant-type heads. Provide sex-type bolts for through-bolt applications. For concealed anchors, use stainless-steel, hot-dip galvanized-steel, or other rust-resistant, protective-coated steel compatible with related materials.

2.3 FABRICATION

- A. Overhead-Braced Units: Provide stainless steel supports, leveling mechanism, and anchors at pilasters to suit floor conditions. Provide shoes at pilasters to conceal supports and leveling mechanism.
- B. Floor-Anchored Units: Provide stainless steel anchoring assemblies with leveling adjustment nuts at pilasters for structural connection to floor. Provide shoes at pilasters to conceal anchorage.
- C. Urinal-Screen Posts: Provide stainless steel anchoring assemblies with leveling adjustment nuts at tops and bottoms of posts. Provide shoes and sleeves (caps) at posts to conceal anchorage.

- D. Doors: Unless otherwise indicated, provide 24-inch- wide, in-swinging doors for standard toilet compartments and 36-inch- wide, out-swinging doors with a minimum 32-inch- wide, clear opening for compartments designated as accessible.
1. Hinges: Continuous full height of door can be adjusted to hold doors open at any angle up to 90 degrees.
 2. Latch and Keeper: Manufacturer's standard recessed latch unit designed for emergency access and with combination rubber-faced door strike and keeper. Provide units that comply with accessibility requirements of authorities having jurisdiction at compartments indicated to be accessible to people with disabilities.
 3. Coat Hook: Manufacturer's standard combination hook and rubber-tipped bumper, sized to prevent door from hitting compartment-mounted accessories.
 4. Door Bumper: Manufacturer's standard rubber-tipped bumper at out-swinging doors.
 5. Door Pull: Manufacturer's standard unit at out-swinging doors that complies with accessibility requirements of authorities having jurisdiction. Provide units on both sides of doors at compartments indicated to be accessible to people with disabilities.

PART 3 - EXECUTION

3.1 INSTALLATION

- A. General: Comply with manufacturer's written installation instructions. Install units rigid, straight, level, and plumb. Secure units in position with manufacturer's recommended anchoring devices.
1. Maximum Clearances:
 - a. Pilasters and Panels: 1/2 inch.
 - b. Panels and Walls: 1 inch.
 2. Full-Height (Continuous) Brackets: Secure panels to walls and to pilasters with full-height brackets.
 - a. Locate bracket fasteners so holes for wall anchors occur in masonry or tile joints.
 - b. Align brackets at pilasters with brackets at walls.
- B. Overhead-Braced Units: Secure pilasters to floor and level, plumb, and tighten. Set pilasters with anchors penetrating not less than 1-3/4 inches into structural floor unless otherwise indicated in manufacturer's written instructions. Secure continuous head rail to each pilaster with no fewer than two fasteners. Hang doors to align tops of doors with tops of panels, and adjust so tops of doors are parallel with overhead brace when doors are in closed position.
- C. Urinal Screens: Attach with anchoring devices to suit supporting structure. Set units level and plumb, rigid, and secured to resist lateral impact. Provide wall and floor anchors.

3.2 ADJUSTING

- A. Hardware Adjustment: Adjust and lubricate hardware according to hardware manufacturer's written instructions for proper operation. Set hinges on in-swinging doors to hold doors open

approximately 30 degrees from closed position when unlatched. Set hinges on out-swinging doors to return doors to fully closed position.

END OF SECTION 102113.19

SECTION 102800 - TOILET, BATH, AND LAUNDRY ACCESSORIES

PART 1 - GENERAL

1.1 SUMMARY

- A. Section Includes:
 - 1. Public-use washroom accessories.

1.2 ACTION SUBMITTALS

- A. Product Data: For each type of product indicated.
- B. Product Schedule: Indicating types, quantities, sizes, and installation locations by room of each accessory required.
 - 1. Identify products using designations indicated.

1.3 INFORMATIONAL SUBMITTALS

- A. Warranty: Sample of special warranty.

1.4 CLOSEOUT SUBMITTALS

- A. Maintenance data.

1.5 QUALITY ASSURANCE

- A. Accessory Locations: Coordinate accessory locations with other work to avoid interference and to assure proper operation and servicing of accessory unit.
- B. Products: Provide products of same manufacturer for each type of accessory unit and for units exposed in same areas, unless otherwise acceptable to Architect.

1.6 WARRANTY

- A. Special Mirror Warranty: Manufacturer's standard form in which manufacturer agrees to replace mirrors that develop visible silver spoilage defects and that fail in materials or workmanship within specified warranty period.
 - 1. Warranty Period: 15 years from date of Final Acceptance.

PART 2 - PRODUCTS

2.1 PUBLIC-USE WASHROOM ACCESSORIES

- A. Manufacturers: Subject to compliance with requirements, provide products by one of the following:
1. A & J Washroom Accessories, Inc.
 2. American Specialties, Inc.
 3. Bobrick Washroom Equipment, Inc.
 4. Bradley Corporation.
 5. GAMCO Specialty Accessories; a division of Bobrick Washroom Equipment, Inc.
 6. Tubular Specialties Manufacturing, Inc.
- B. Grab Bar, 18", #T1:
1. Basis-of-Design Product: Bobrick #B-6806 Series.
 2. Mounting: Flanges with concealed fasteners.
 3. Material: Stainless steel, 0.05 inch thick.
 - a. Finish: Smooth, No. 4 finish (satin) on ends and slip-resistant texture in grip area.
 4. Outside Diameter: 1-1/2 inches.
 5. Configuration and Length: Straight, 18 inches long.
- C. Grab Bar, 42", #T2:
1. Basis-of-Design Product: Bobrick #B-6806 Series.
 2. Mounting: Flanges with concealed fasteners.
 3. Material: Stainless steel, 0.05 inch thick.
 - a. Finish: Smooth, No. 4 finish (satin) on ends and slip-resistant texture in grip area.
 4. Outside Diameter: 1-1/2 inches.
 5. Configuration and Length: Straight, 42 inches long.
- D. Grab Bar, 36", #T3:
1. Basis-of-Design Product: Bobrick #B-6806 Series.
 2. Mounting: Flanges with concealed fasteners.
 3. Material: Stainless steel, 0.05 inch thick.
 - a. Finish: Smooth, No. 4 finish (satin) on ends and slip-resistant texture in grip area.
 4. Outside Diameter: 1-1/2 inches.
 5. Configuration and Length: Straight, 36 inches long.
- E. Toilet Tissue (Roll) Dispenser #T4:
1. Basis-of-Design Product: Von Drehle 3253, Twin JRT Dispenser 3" core.
 2. Description: Double-roll dispenser (Non-controlled delivery).
 3. Mounting: Surface mounted.

4. Operation: Locking feature.
5. Capacity: Designed for 3.3" core tissue rolls up to 9" in diameter.
6. Material and Finish: Polycarbonate cover with polystyrene base.

A. Sanitary Napkin Disposal #T5:

1. Basis-of-Design Product: ASI - Napkin Disposal - 10 -0852.
2. Description: Surface mounted sanitary napkin disposal.
3. Mounting: Surface mounted.
4. Operation: Spindles removed by special key. Theft resistant.
5. Capacity: 1.2 gallon.
6. Material and Finish: 304 Stainless Steel, No. 4 satin finish.

B. Mirror Unit #T6 & T10:

1. Basis-of-Design Product: Bobrick #B-2908 Custom Tempered Glass.
2. Frame: Stainless-steel angle, 0.05 inch thick.
 - a. Corners: Welded and ground smooth.
3. Hangers: Produce rigid, tamper- and theft-resistant installation, using method indicated below.
 - a. One-piece, galvanized-steel, wall-hanger device with spring-action locking mechanism to hold mirror unit in position with no exposed screws or bolts.
 - b. Wall bracket of galvanized steel, equipped with concealed locking devices requiring a special tool to remove.
4. Size: As indicated on Drawings.

C. Surface Mounted Coat Hook #T7:

1. Basis-of-Design Product: Bobrick #B-6717 Surface Mounted Coat Hook
2. Mounting: Wall mounted, concealed wall plate, stain finish
3. Materials: Type-304 Stainless Steel

D. Liquid-Soap Dispenser #T8: (Owner Provided; Contractor Installed). Information provided for reference only.

1. Basis-of-Design Product: Gojo #1980-04 LTX-12 1200ml.
2. Description: Designed for dispensing soap in liquid or lotion form.
3. Mounting: Wall mounted.
4. Capacity: 1200 ml.
5. Materials: Durable ABS plastic with rugged polycarbonate view windows.
6. Batteries: Requires four D-cell batteries.
7. Refill Indicator: none.

E. Towel (Roll) Dispenser #T9: (Owner Provide; Contractor Installed). Information provided for reference only.

1. Basis-of-Design Product: Von Drehle 8080E.
2. Description: Electronic roll towel dispenser.

3. Mounting: Surface mount.
4. Material and Finish: ABS Plastic (cover and base)
5. Feed Settings: Programmable.

2.2 FABRICATION

- A. Keys: Provide universal keys for internal access to accessories for servicing and resupplying. Provide minimum of six keys to Owner's representative.

PART 3 - EXECUTION

3.1 INSTALLATION

- A. Install accessories according to manufacturers; written instructions, using fasteners appropriate to substrate indicated and recommended by unit manufacturer. Install units level, plumb, and firmly anchored in locations and at heights indicated.
- B. Grab Bars: Install to withstand a downward load of at least 250 lbf, when tested according to ASTM F 446.

3.2 ADJUSTING AND CLEANING

- A. Adjust toilet accessories for proper operation and verify that mechanisms function smoothly. Replace damaged or defective items.
- B. Remove temporary labels and protective coatings.
- C. Clean and polish all exposed surfaces after removing protective coatings.

END OF SECTION 102800

SECTION 104413 - FIRE EXTINGUISHERS CABINETS AND ACCESSORIES

PART 1 - GENERAL

1.1 RELATED DOCUMENTS

- A. Drawings and general provisions of Contract, including General and Supplementary Conditions and Division 01 Specification sections, apply to work of this section.

1.2 DESCRIPTION OF WORK

- A. Extent of fire extinguishers, cabinets and accessories is indicated on drawings.
- B. Definition: "Fire extinguishers" as used in this section refers to units which can be hand-carried as opposed to those which are equipped with wheels or to fixed fire extinguishing systems.
- C. Types of products required include:
 - 1. Fire extinguishers with enclosed cabinets.
 - 2. Fire extinguishers with surface mounted brackets.

1.3 QUALITY ASSURANCE

- A. Single Source Responsibility: Obtain products in this section from one manufacturer.
- B. UL-Listed Products: Provide new portable fire extinguishers which are UL-listed and bear UL "Listing Mark" for type, rating, and classification of extinguisher indicated.

1.4 SUBMITTALS

- A. Product Data: Submit product data for each type of product included in this section. For fire extinguisher cabinets include roughing-in dimensions and details showing mounting methods, relationships of box and trim to surrounding construction, door hardware, cabinet type and materials, trim style and door construction, and panel style and materials.

PART 2 - PRODUCTS

2.1 ACCEPTABLE MANUFACTURERS

- A. Basis of Design: Cabinets as indicated are "Cosmopolitan" series cabinets as manufactured by J-L Industries. Subject to compliance with requirements, products of a similar style, trim and finish will be considered by the following:
 - 1. Larsen Manufacturing, Ambassador Series.
 - 2. Potter-Roemer, Alta Series.
- B. Provide clear acrylic or tempered glass vertical "slot" lite.

2.2 FIRE EXTINGUISHERS

- A. General: Provide fire extinguishers for each extinguisher cabinet.
- B. Multi-Purpose Dry Chemical Type: UL-rated 4-A:60-B: C, 10 lb. nominal capacity, in enameled steel container, for Class A, Class B and Class C fires.

2.3 FIRE EXTINGUISHER CABINETS

- A. General: Provide fire extinguisher cabinets where indicated, of suitable size for housing fire extinguishers of types and capacities indicated.
- B. Construction: Manufacturer's standard colored anodized or enameled steel box depending on style indicated, with trim, frame, door and hardware to suit cabinet type, trim style, and door style indicated. Weld all joints and grind smooth. Miter and weld perimeter door frames.
- C. Cabinets suitable for mounting conditions indicated, of the following types as indicated.
- D. Fully Recessed: Cabinet box (tub) fully recessed in walls of sufficient depth to suit style of trim indicated.
 - 1. Partial lite door, with 5/16 square edge trim, fully recessed box, with pull handle.
 - 2. Finish: #4 finish Stainless steel.
 - 3. Lettering: Engraved vertically on door. Red color fill.
- E. Semi-Recessed: Cabinet box partially recessed with face frame projecting from finished wall.
 - 1. Partial lite door, 2 1/2 inch rolled edge one piece trim, mitered corners.
 - 2. Finish: #4 finish Stainless Steel.
 - 3. Trim Metal: Match door face.
- F. Lettering: Engraved in door. Red color fill.
- G. Door Material and Construction: Manufacturer's standard door construction, of material indicated, coordinated with cabinet types and trim styles selected.
- H. Steel or aluminum tubs: Manufacturer's standard folded and seamed construction, powder coated finish.
- I. Door Hardware: Provide manufacturer's standard door operating hardware of proper type for cabinet type, trim style, and door material and style indicated. Provide either lever handle with cam action latch, or door pull, exposed or concealed, and friction latch. Provide concealed or continuous type hinge permitting door to open 180 degrees.
- J. Finish: Match door and trim finish.
- K. Quantity: As indicated on the drawings, or as required by authority having jurisdiction, whichever is greater.

2.3 ACCESSORIES

A. Mounting Brackets: Manufacturer's standard steel, designed to secure extinguisher, of sizes required for types and capacities of extinguishers indicated, with plated or baked-enamel finish.

1. Provide brackets for extinguishers not located in cabinets.

PART 3 - EXECUTION

3.1 INSTALLATION

A. Confirm location and mounting height with authority having jurisdiction prior to installation.

B. Install items included in this section in locations and at mounting heights indicated, if approved by applicable regulations of governing authorities.

C. Prepare recesses in walls for fire extinguisher cabinets as required by type and size of cabinet and style of trim and to comply with manufacturer's instructions.

END OF SECTION 104413

SECTION 122413 – ROLLER SHADES

PART 1 - GENERAL

1.1 SUMMARY

- A. This Section includes
 - 1. Manual roller shades; shading fabrics, as indicated.

1.2 SUBMITTALS

- A. Product Data: For each type of product indicated.
- B. Shop Drawings: Include plans, elevations, sections, details, details of installation, and operational clearances to adjoining Work.
 - 1. Verify dimensions by field measurements before fabrication and indicate measurements on Shop Drawings.
- C. Coordination Drawings: Drawn to scale and coordinating penetrations and ceiling-mounted items. Provide templates to General Contractor for preparing drapery or shade pockets.
- D. Samples: For each fabric indicated in schedules.
- E. Maintenance data.

1.3 QUALITY ASSURANCE

- A. Installer Qualifications: Minimum of 5 years successful experience installing electrically operated roller shade products of similar size and scope.
- B. Fire-Test-Response Characteristics: Provide products passing flame-resistance testing according to NFPA 701.
- C. Comply with WCMA A 100.1.

PART 2 - PRODUCTS

2.1 MANUAL ROLLER SHADES

- A. Basis-of-Design Product: Subject to compliance with requirements, provide Draper Manuel Flexshade or comparable product by one of the following:
 - 1. Draper, Inc.

2. Lutron Electronics Co., Inc.
 3. MechoShade Systems, Inc.
- B. All shades, manual or electrically operated, shall be provided by the same manufacturer in compatible styles and enclosures.
- C. Operator: Clutch / Gear mounted at roller with continuous steel chain with sill mounted tensioned keeper on pulley or gear.
- D. Enclosures are to match the adjacent window framing.

2.2 ROLLER SHADE FABRICATION

- A. Unit Sizes: Obtain units fabricated in sizes to fill window and other openings as follows, measured at 74 deg F:
1. Shade Units Installed between (Inside) Jambs: Edge of shade not more than 1/4 inch from face of jamb. Length equal to head to sill dimension of opening in which each shade is installed.
- B. Rollers: Extruded-aluminum tube of diameter and wall thickness required to support and fit internal components of operating system and the weight and width of shade band material without sagging; designed to be easily removable from support brackets. Provide capacity for one roller shade band(s) per roller.
1. Direction of Roll: Regular, from back of roller.
- C. Mounting Brackets: Provide types as needed for installations detailed.
- D. Fascia: L-shaped, formed-steel sheet or extruded aluminum; long edges returned or rolled; continuous panel concealing front and bottom of shade roller, brackets, and operating hardware and operators; length as indicated on Drawings; removable design for access.
1. Finish aluminum to match adjacent window framing system.
- E. Top/Back Cover: L-shaped; material and finish to match fascia; combining with fascia and end caps to form a six-sided headbox enclosure sized to fit shade roller and operating hardware inside.
1. Provide completely enclosed and pre-finished extruded aluminum enclosure for surface mounted, exposed locations where indicated. No exposed fasteners with mounting.
- F. Hem Bar: Extruded aluminum, with plastic or metal capped ends. Provide concealed type, thermally sealed within the shade fabric.
- G. Mounting: Mounting varies with both inside jamb and face mounting applications, as indicated.

2.3 MANUAL SHADE OPERATORS

- A. Clutch Brake system

1. General

- a. Clutch Roller Shades shall be a ball chain-operated system utilizing a bidirectional wrap spring clutch.
- b. The system must be capable of raising and lowering the shade to any desired height and maintaining that position.
- c. The shade shall operate by the chain only. Hem bar will not disengage the clutch.
- d. The system will provide a maximum fabric gap of 0.75" per side.

B. Clutch and Tube Specifications

1. Bi-directional wrap spring clutch, self adjusting.
2. Shade stop upon release of clutch.
3. Clutch mounted on either the right or left end of the roller tube and fabric may be forward or reverse rolled. Mount clutch the same within the same room or area.
 - a. Clutch is fabricated of high-strength fiberglass reinforced polyester with high carbon steel springs.
 - b. Manufacturer shall size the appropriate shade tube and clutch size based on shade size, fabric type, and application requirements to avoid deflection along length of tube.
 - c. Fabric shall be connected to tube with double-sided adhesive strip or retaining slot engaging edge of fabric.

C. Clutch Control Loop

1. Chain: Cast steel, aluminum or plastic beads. Color: As selected by Architect from manufacturers standard colors.
2. Chain connector to be fitted with upper and lower ball stops.
3. Extend chain full length of window opening and to within 2 inches of sill. Remove excess length that does not allow chain to hang freely.

D. Clutch Idle End Cap: Two-piece unit consisting of an outside sleeve and center bearing shaft made of high-strength fiberglass reinforced polyester.

E. Clutch Mounting Brackets

1. Material: Manufacturer's standard.
2. Universal mount for inside, outside or ceiling, with the clutch on either the right or left side of the roller.
3. The clutch mounts flush to the face of the bracket.

2.4 SHADEBAND MATERIALS

- A. Shadeband Material Flame-Resistance Rating: Comply with NFPA 701. Testing by a qualified testing agency. Identify products with appropriate markings of applicable testing agency.
- B. Light-Filtering Fabric: Woven fabric, stain and fade resistant.
 1. Source: Roller-shade manufacturer or approved manufacturer.

2. Type: PVC-coated fiberglass.
3. Weave: Full Basketweave.
4. Thickness: Average thickness 0.019”.
5. Weight: Average 13.90 oz./sq. yd.
6. Roll Width: See Drawings.
7. Orientation on Shadeband: Up the bolt.
8. Openness Factor: 3 percent.
9. Color: As selected by Architect from manufacturer's full range.

PART 3 - EXECUTION

3.1 ROLLER SHADE INSTALLATION

- A. Install roller shades level, plumb, and aligned with adjacent units according to manufacturer's written instructions, and located so shade band is not closer than 2 inches to interior face of glass. Allow clearances for window operation hardware.
- B. Adjust and balance roller shades to operate smoothly, easily, safely, and free from binding or malfunction throughout entire operational range, train owner's personnel to adjust, operate, and maintain roller shades.
- C. Clean roller shade surfaces after installation, according to manufacturer's written instructions.

END OF SECTION 122413

SECTION 142400.5 - HYDRAULIC ELEVATOR MODERNIZATION (SEE ALTERNATE #11)

PART 1 - GENERAL

1.1 SUMMARY

- A. Section includes hydraulic **passenger** elevator modernization.

1.2 ACTION SUBMITTALS

- A. Product Data: Include capacities, sizes, performances, operations, safety features, finishes, and similar information.
- B. Shop Drawings:
 - 1. Include plans, elevations, sections, and large-scale details indicating service at each landing, machine room layout, coordination with building structure, relationships with other construction, and locations of equipment.
 - 2. Indicate maximum dynamic and static loads imposed on building structure at points of support, and maximum and average power demands.
- C. Samples: For exposed finishes.

1.3 INFORMATIONAL SUBMITTALS

- A. Seismic Qualification Certificates: For elevator equipment, accessories, and components, from manufacturer.
- B. Manufacturer Certificates: Signed by elevator manufacturer certifying that hoistway, pit, and machine room layout and dimensions, as shown on Drawings, and electrical service as shown and specified, are adequate for elevator system being provided.

1.4 CLOSEOUT SUBMITTALS

- A. Operation and Maintenance Data: For elevators to include in emergency, operation, and maintenance manuals.
- B. Inspection and Acceptance Certificates and Operating Permits: As required by authorities having jurisdiction for normal, unrestricted elevator use.
- C. Continuing Maintenance Proposal: Submit a continuing maintenance proposal from Installer to Owner, in the form of a standard **two-year** maintenance agreement, starting on date initial maintenance service is concluded. State services, obligations, conditions, and terms for agreement period and for future renewal options.

1.5 WARRANTY

- A. Manufacturer's Special Warranty: Manufacturer agrees to repair, restore, or replace elevator work that fails in materials or workmanship within specified warranty period.
 - 1. Warranty Period: One year from date of Final Acceptance.

PART 2 - PRODUCTS

2.1 MANUFACTURERS

- A. Basis-of-Design Product: Subject to compliance with requirements, provide elevator modernization by TKE (ThyssenKrupp Elevator) or comparable product by one of the following:
 - 1. KONE Inc.
 - 2. Otis Elevator Co.
 - 3. Schindler Elevator Corp.
- B. **See Specification Section ALTERNATES 012300. Elevator Modernization is (Owner Preferred) Alternate #11.**

2.2 PERFORMANCE REQUIREMENTS

- A. Regulatory Requirements: Comply with ASME A17.1/CSA B44.
- B. Accessibility Requirements: Comply with Section 407 in the U.S. Architectural & Transportation Barriers Compliance Board's ADA-ABA Accessibility Guidelines and with ICC A117.1.
- C. Seismic Performance: New work to elevator system shall withstand the effects of earthquake motions determined according to **ASCE 7** and shall comply with elevator safety requirements for seismic risk Zone 2 or greater in ASME A17.1/CSA B44.

2.3 ELEVATOR MODERNIZATION

- A. Elevator System, General: Manufacturer's standard elevator systems. Unless otherwise indicated, manufacturers' standard components shall be used, as included in standard elevator systems and as required for complete system.
- B. Elevator Modernization – Scope of Work:
 - 1. Controller – New:
 - a. Two-way Communication Machine Room Equipment (Primary Box)
 - b. MAX Link 2-Line ATA kit
 - c. TAC 32 Controller (Includes Options listed below)

- i. 24 VDC Signal Voltage
 - ii. Auto Light and Fan Feature
 - iii. Car Independent Service
 - iv. Car Traveling Lantern Circuitry
 - v. Door Bypass Operation
 - vi. Electronic Door Detector Interface
 - vii. Hoistway Access and Enable
 - viii. THY Board
 - d. Solid State Starters (6 or 12 leads) 208 VAC
 - e. Battery Lowering in Controller
 - f. eMax Monitoring Device Provisions
- 2. Power Unit – New:
 - a. Hydraulic Oil – Remove and dispose of the existing oil.
 - b. 5 gallon drum of Biodegradable oil
 - c. 55 gallon drum of Biodegradable oil
 - d. EP-95 Power Unit (Submersible)
 - e. 2" Shutoff Valve Kit (Pump)
- 3. Jack – Retain Existing
 - a. New: Hydraulic Jack Packing – Remove and replace the existing packing with new
 - b. New: Pipe Stands (Safety Requirement)
- 4. Car – New:
 - a. Crosshead data tag (for existing car slings)
 - b. 21" Toe guard
 - c. Fan: Two Speed
 - d. Car Top Exit Switch
 - e. Two-way Communication Camera (dome), Ethernet Extender (kit), & Battery Backup
 - f. Cab Wiring Material (200MK1)
- 5. Hoistway – New:
 - a. HN Boxes (per each 2 cars, grouped)
 - b. Base Wiring Package for 2019 Code
 - c. Steel Tape with Mounting hardware, Selector and magnets (terminal limits included)
 - d. Hoistway Duct Kit
 - e. Single traveling cable, hoistway wiring, interlock wiring, interlock connectors, and serial wiring.

6. Pit – New:
 - a. Pit Flood Switch (Code Requirement)
 - b. Pit Ladder (Code Requirement)
 - c. Pit Stop Switch

7. Cab Interior Renovation – A Vertical 7-Panel Cab Interior configuration will be provided for the elevator. This interior renovation includes:
 - a. 7 Vertical Laminate Panels (finish to be selected by owner)
 - b. Stainless Steel Base
 - c. Stainless Steel Reveals
 - d. 6 Light LED Dropdown Ceiling w/ Stainless Steel Face & Dimmer Control
 - e. 2" Flat Brushed Stainless Steel ADA compliant Handrail on Rear Wall

8. Door Equipment – New:
 - a. Standard Car Door Clutch Assembly
 - b. Micro Light 3D Electronic Door Edge
 - c. LD-16 Plus Drive Only Operator Package
 - i. includes Car Top Inspection station (w/ alarm signal)
 - d. Front Car Door and Hatch Side Restrictors (vanes) complete kit
 - e. 3D Cabsafe Components Package
 - f. Car Top Inspection Station Flooded Pit Jewel

9. Car Fixtures – New:
 - a. Main Car Station Includes Options Below
 - i. Swing Return (Full Width/Wrap Around Swing Return)
 - b. Vandal Resistant Floor Buttons
 - c. Debranded Car Station (No Logo)
 - d. Cast Braille Plates for Car Features
 - e. Standard Key Switch Package
 - i. Fan
 - ii. Light
 - iii. Independent
 - iv. Stop
 - v. Inspection/Hoistway Enable
 - f. Emergency Light mounted in COP
 - g. 2004 and later Fire Service Phase II Features (includes instructions signage)
 - h. Handicap Signal (Passing signal)
 - i. Position Indicator (2" CE Segmented)
 - j. ADA Phone System integral with COP (Rath)
 - k. Speaker Pattern for Intercom System/ADA Phone
 - l. Locked Service Cabinet
 - m. Certificate Window
 - n. Default Engravings
 - o. GFI Outlet
 - p. Emergency Light Test Button/Keyswitch

- q. Voice Annunciator (mounted in COP)
 - i. Standard features only
- r. TAC Serial Boards (Main)
- s. Car Riding Lantern (Standard) #4 Brushed Stainless Steel

10. Hall Fixtures – New:

- a. Serial Boards for Hoistway Access
- b. Fire Service Phase I Key Switch
- c. Fire Service Phase I Engraved Instructions
- d. Hoistway Access Switch (in Hall Station)
- e. Hoistway Jamb Braille (Pair of Standard) (All Floors)
- f. Terminal Hall Stations (Surface Mounted) with
 - i. Appendix O (Polycarbonate insert flame)
 - ii. Fusion (#4 Stainless Steel finish)
- g. 2009 & 2010 Elevator Communications Failure add
- h. Serial Boards for Front Risers
- i. TAC Serial Boards, Base Charge

2.4 FINISH MATERIALS

- A. Cold-Rolled Steel Sheet: ASTM A 1008/A 1008M, commercial steel, Type B, exposed, matte finish.
- B. Hot-Rolled Steel Sheet: ASTM A 1011/A 1011M, commercial steel, Type B, pickled.
- C. Stainless-Steel Sheet: ASTM A 240/A 240M, Type 304.
- D. Stainless-Steel Bars: ASTM A 276, Type 304.
- E. Stainless-Steel Tubing: ASTM A 554, Grade MT 304.
- F. Aluminum Extrusions: ASTM B 221 (ASTM B 221M), Alloy 6063.
- G. Plastic Laminate: High-pressure type complying with NEMA LD 3, Type HGS or Type HGL.

PART 3 - EXECUTION

3.1 FIELD QUALITY CONTROL

- A. Acceptance Testing: On completion of elevator installation and before permitting elevator use (either temporary or permanent), perform acceptance tests as required and recommended by ASME A17.1/CSA B44 and by governing regulations and agencies.

3.2 PROTECTION

- A. Temporary Use: Do Not Use For Construction Purposes

3.3 DEMONSTRATION

- A. Engage a factory-authorized service representative to train Owner's maintenance personnel to operate, adjust, and maintain elevator(s).

3.4 MAINTENANCE

- A. Initial Maintenance Service: Beginning at Final Acceptance, maintenance service shall include 12 months' full maintenance by skilled employees of elevator Installer. Include monthly preventive maintenance, repair or replacement of worn or defective components, lubrication, cleaning, and adjusting as required for proper elevator operation. Parts and supplies shall be manufacturer's authorized replacement parts and supplies.

END OF SECTION 142400.5